

the future of space conditioning

Eco HQ™

active chilled beam

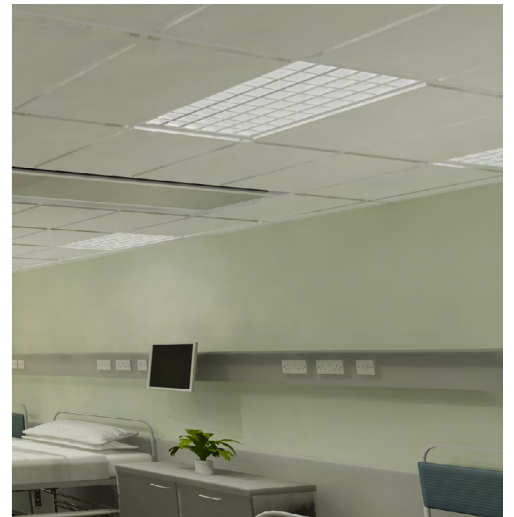



Contents

Product Description	3
Cooling Performance	4
Heating Performance	5
Cooling Selection Tables	6
Cooling Only	6
Cooling & Heating	8
Heating Selection Tables	10
Air Cooling Effect	12
Scatter Diagram	12
Product Dimensions	13
Eco HQ 125	13
Eco HQ 160	14
Mounting Details	13
Eco 125	13
Eco 160	14
Lighting Options	15
Perforation Pattern Options	16
Product Ordering Codes	16
Calculation Program	17
Project Specific Testing Facility	18
Photometric Testing Facility	19
Acoustic Testing Facility	20

Product Description

Eco HQ is one of Frenger's latest range of high performance Chilled Beams. Energy efficiency has been a key driver for such advancements in Frenger's Chilled Beam Technology.

Eco HQ is 227mm deep as standard and can be increased to **267mm deep for higher air volumes**. Eco can achieve **1258watts per meter total cooling** (based on 10Δtk and 25 ltrs/sec/m for a beam supplied at 16°C with a 100 Pa, cooling only beam).

The Eco HQ is constructed from 'High Quality' extruded aluminium side profiles, powdercoat finish to all visible components that not only makes for a robust product that has precision interfaces, but also enhances performance. This beam also contains a number of **Frenger's Patent pending performance enhancing features** and as can be expected from the Frenger brand, the Eco HQ beam is also designed to be easily tailored to suit the unique parameters of individual project sites, for the optimum product / system efficiencies. This is partly achieved by Frenger's "burst nozzle" arrangement that not only encourages induction, but also reduces noise. Given the size and amount of burst nozzles being appropriately quantified for each project, this provides consistent jet velocities, equal distribution of the air discharge and continuous induction through the entire length of the heat exchanger (battery). There are no dead spots due to plugging back nozzle sizes as associated with many competitors' active beams as dead spots and / or reduced jet velocities decrease their cooling capacities / efficiencies.

Frenger's heat exchanger batteries are also fitted with extruded aluminium profiles to not only enhance performance but also provide a continuous clip on facility for the underplate. This arrangement keeps the underplates true and flat for long lengths, even up to 3.6m.

Eco HQ can be used in most types of commercial building where a value engineered solution is preferred such as for ceiling integration. Eco HQ units are "**powdercoat**" finished in RAL 9010 (20% Gloss) White as standard.

Eco HQ is available in any length from 1.2m up to 3.6m in 0.1m increments and it constructed from a combination of zinc coated mild steel for non critical components, extruded aluminium where precision and a high quality robust construction is required.

The air chamber for Eco HQ is the largest in Frenger's product range and can accommodate up to 90 ltrs/sec with its 160mm diameter single air inlet connection point.

Eco HQ beams have a "closed back", thus meaning that all induced air (recirculated room air) is induced through the underplate within the room space to avoid any need for perimeter flash gaps and / or openings in the ceiling system. This also provides for a better quality of recirculated air as the recirculated air does not mix with any air from the ceiling void. The induction ratio of Eco HQ is typically 5 times that of the supply air (fresh air) rate.



In addition to Eco's high cooling performance capability of in excess of 1000 watts per meter, **Eco HQ can operate well and induce at low air volumes, as little as 3 l/s/m and even with a low static pressure of just 40Pa. Likewise Eco HQ can handle high air volumes up to 30 l/s/m and up to 120 Pa.** Please note however that these high air volumes should be avoided wherever possible and are the absolute maximum and should not ever be exceeded. As a "rule of thumb" 25 ltrs/sec/m from a 2 way discharge beam is the maximum for occupancy comfort compliance to BS EN 7730.

Eco HQ can have integrated heating with separate connections (2 pipe connections for cooling and 2 pipes for heating).

The maximum total supply air for the product is limited to 90 ltrs/sec, which equates to 25 ltrs/sec/m for a 3.6m long beam.

Eco HQ is available with a drop down exchange battery for easy cleaning to all 4 sides of the heat exchanger - see Frenger's separate Eco-Healthcare HQ™ brochure.

At a glance

- High output "**1258 W/m**" cooling only beam.
- Can accommodate up to 90 ltrs/sec.
- Optimise discharge nozzle sizes and pitch factory set to best suit project requirements.
- Coanda effect is initiated within the beam.
- Discharge veins are concealed within the beam for improved aesthetics.
- **Fan shape distribution for increased occupancy comfort.**
- **Unique fast fixing or removable underplates that prevents any sagging even on long beam lengths of 3.6m.**
- **Various different perforation patterns available for removable underplates.**
- **Multiple manifold variants to enable reduced chilled (and LTHW, if applicable) water mass flow rates to be facilitated for increased energy efficiencies.**
- Operates well at "**Low Pressure**" and "**Low Air Volume**" for **increased energy efficiencies.**
- Provides indoor climate **in accordance with BS EN ISO 7730.**

Cooling Performance

ECO HQ Waterside Cooling Effect at 9.0 dTK
 (Primary Air = 80Pa, Chilled Water = 14/17°C, Room Condition = 24.5°C)

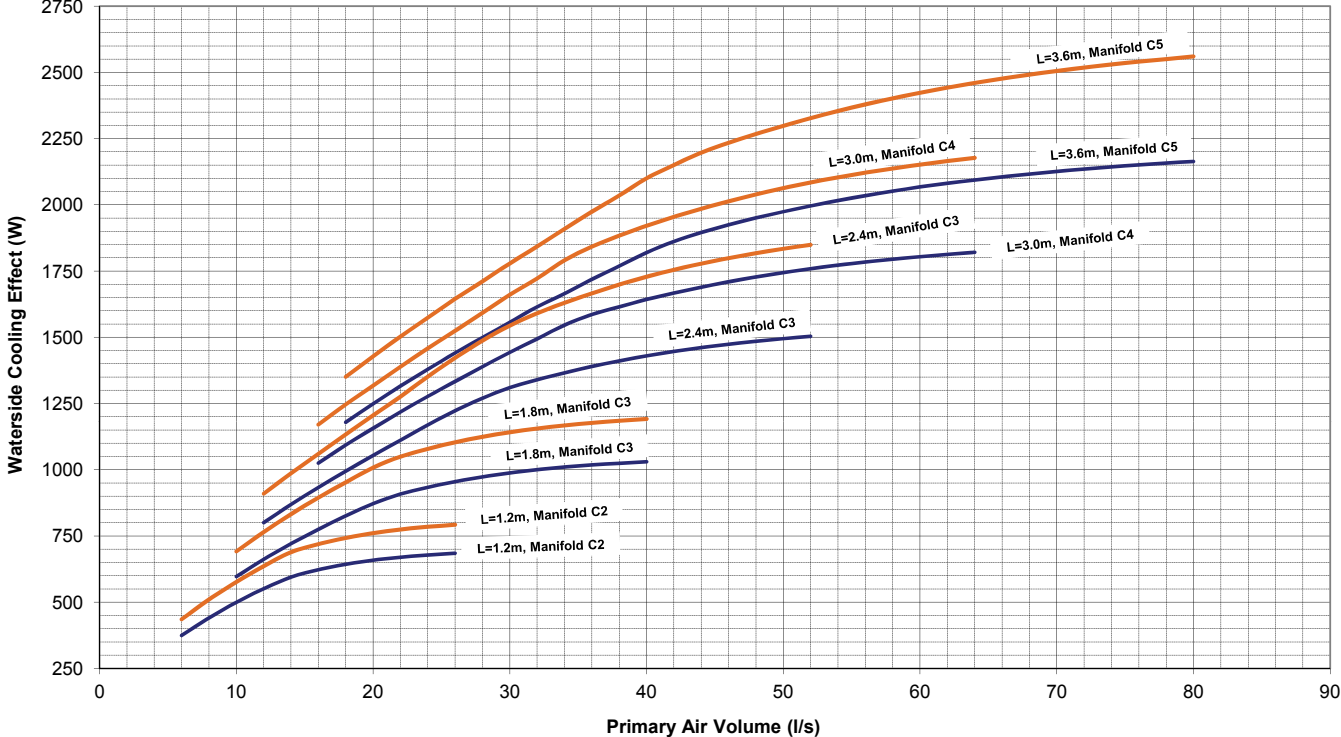

Pressure Drop

Eco Chilled Water Pressure Drop

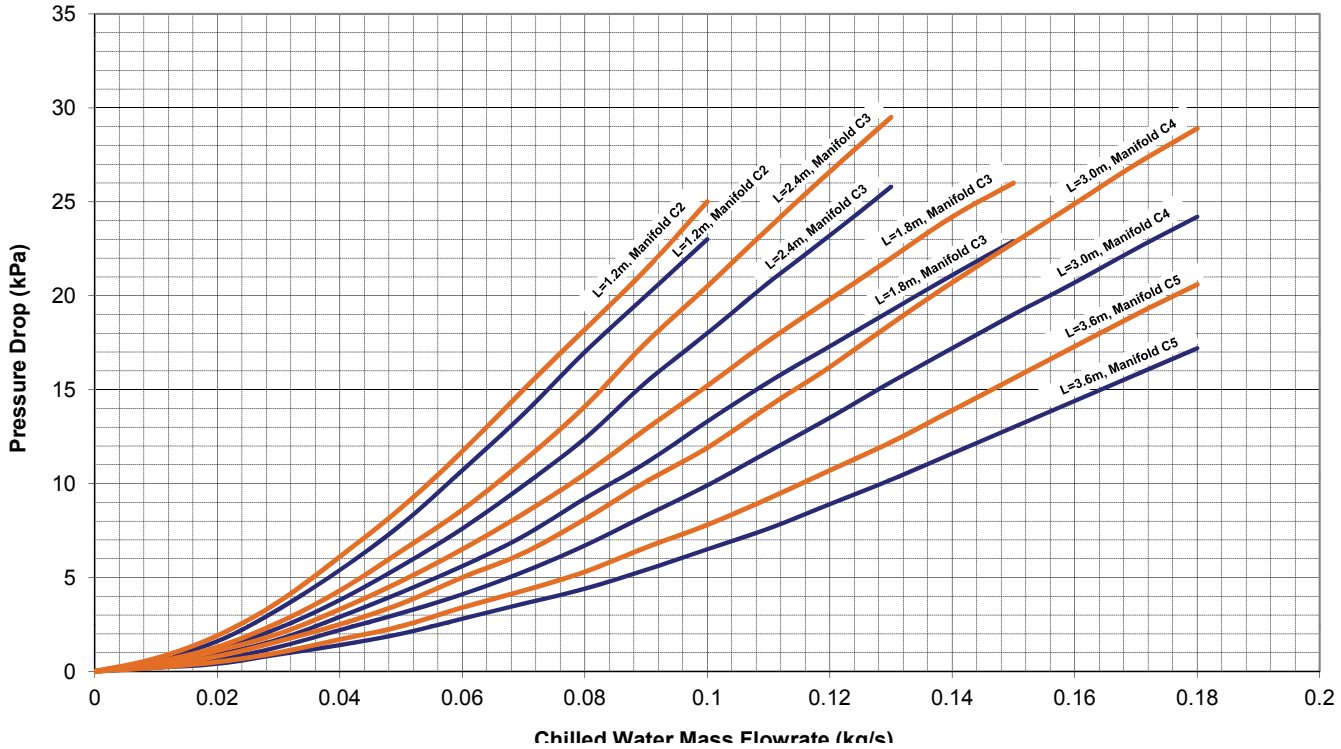

Legend:
— = Cooling Only
— = Cooling & Heating

Heating Performance

Eco HQ Waterside Heating Effect at 24.0 dTK
 (Primary Air = 80Pa, Heating Water = 50/40°C, Room Condition = 21.0°C)

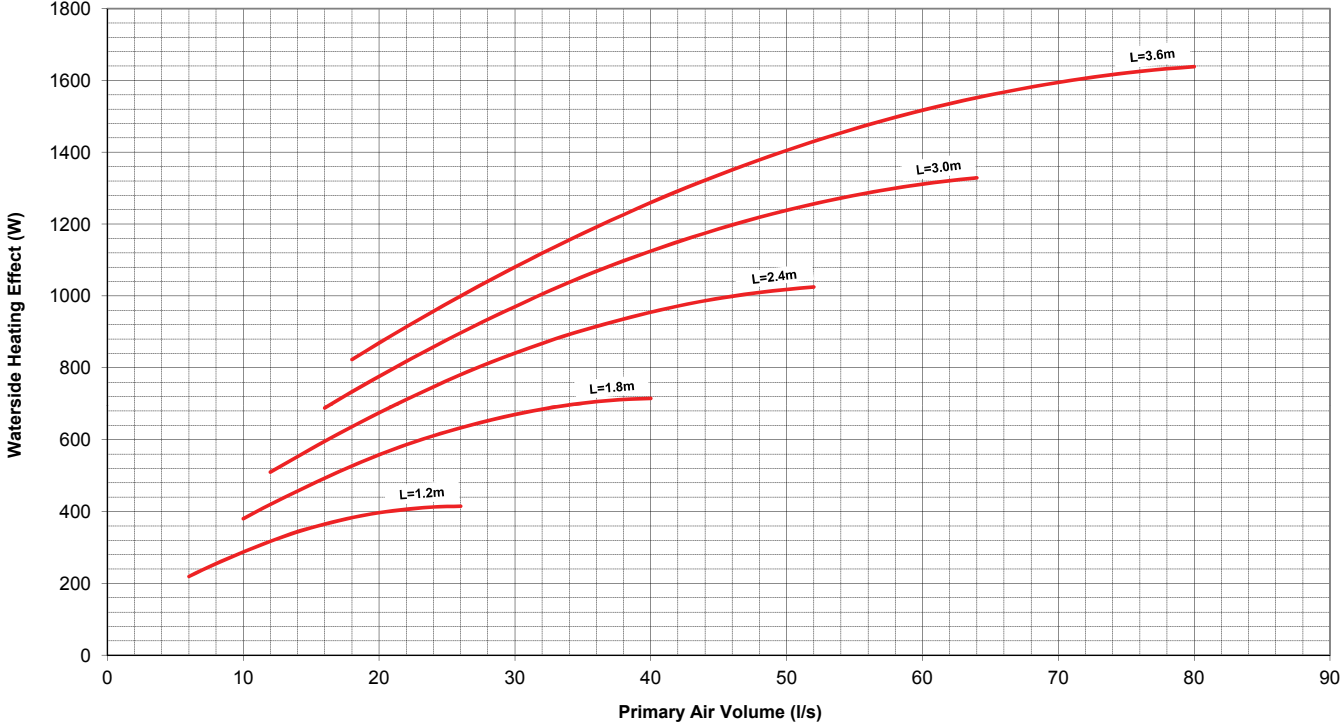

Pressure Drop

Eco Heating Water Pressure Drop

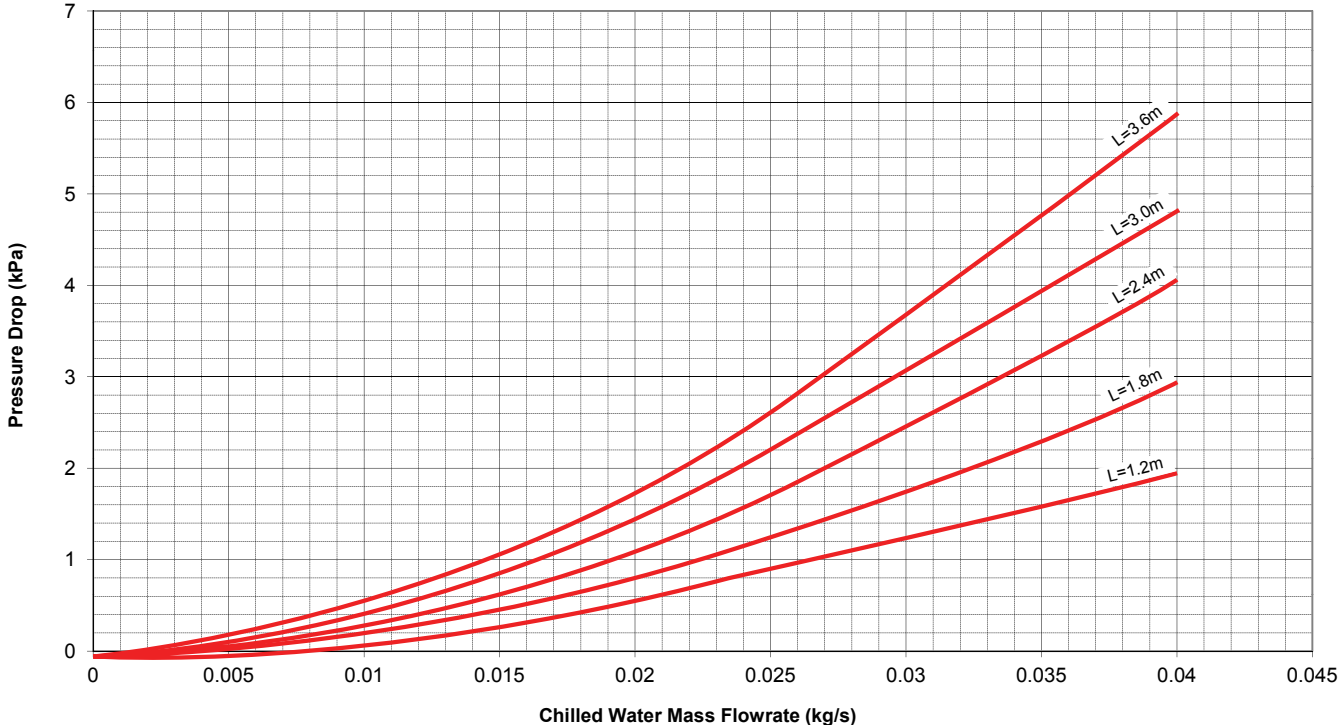

Cooling Selection Tables

Cooling only at 40Pa Nozzle Pressure

Nozzle Pressure 40 Pa		Water															
Q (l/s)	Eco HQ	$\Delta tK - 7^{\circ}C$				$\Delta tK - 8^{\circ}C$				$\Delta tK - 9^{\circ}C$				$\Delta tK - 10^{\circ}C$			
		L (m)	P (w)	p(kg/s)	Manifold	p(kPa)	P (w)	p(kg/s)	Manifold	p(kPa)	P (w)	p(kg/s)	Manifold	p(kPa)	P (w)	p(kg/s)	Manifold
10	1.2	375	0.030	C2	3.6	441	0.035	C2	4.8	507	0.040	C2	6.1	574	0.046	C2	7.5
	1.8	486	0.039	C2	8.5	567	0.045	C2	11.1	651	0.052	C2	13.9	746	0.059	C2	17.3
	2.4	552	0.044	C2	14.1	644	0.051	C2	18.3	682	0.054	C3	7.4	770	0.061	C3	9.1
	3.0	552	0.044	C3	6.4	644	0.051	C3	8.4	737	0.059	C3	10.5	831	0.066	C3	12.9
	3.6	-	-	-	-	-	-	-	-	-	-	-	-	-	-	-	-
20	1.2	-	-	-	-	-	-	-	-	-	-	-	-	-	-	-	-
	1.8	704	0.056	C2	15.7	748	0.059	C3	6.4	861	0.069	C3	8.1	977	0.078	C3	10.0
	2.4	804	0.064	C3	9.7	941	0.075	C3	12.6	1096	0.087	C3	16.0	1148	0.091	C4	8.2
	3.0	932	0.074	C3	15.6	1026	0.082	C4	8.5	1176	0.094	C4	10.7	1335	0.106	C4	13.2
	3.6	973	0.077	C4	9.3	1133	0.090	C4	12.1	1302	0.104	C4	15.2	1491	0.119	C4	18.8
30	1.2	-	-	-	-	-	-	-	-	-	-	-	-	-	-	-	-
	1.8	-	-	-	-	-	-	-	-	-	-	-	-	-	-	-	-
	2.4	947	0.075	C3	12.7	1110	0.088	C3	16.6	1194	0.095	C4	8.6	1353	0.108	C4	10.7
	3.0	1077	0.086	C4	9.1	1261	0.100	C4	11.9	1465	0.117	C4	15.1	1716	0.137	C4	18.9
	3.6	1238	0.099	C4	13.9	1470	0.117	C4	18.2	1585	0.126	C5	11.6	1818	0.145	C5	14.3
40	1.2	-	-	-	-	-	-	-	-	-	-	-	-	-	-	-	-
	1.8	-	-	-	-	-	-	-	-	-	-	-	-	-	-	-	-
	2.4	-	-	-	-	-	-	-	-	-	-	-	-	-	-	-	-
	3.0	1187	0.094	C4	10.7	1388	0.110	C4	14.0	1596	0.127	C4	17.7	1719	0.137	C5	11.0
	3.6	1408	0.112	C4	17.1	1561	0.124	C5	11.2	1805	0.144	C5	14.2	2087	0.166	C5	17.7

Flow-adjusted waterside cooling effect table. Cooling circuit $\Delta t = 3^{\circ}C$ (Water in-out), nozzle pressure of 40 Pa, 1 x $\varnothing 125$ air connection.

For green values, a $\varnothing 22$ manifold connection size is required.

Please refer to Frenger Technical Department for selections not covered within these tables.

Cooling only at 60Pa Nozzle Pressure

Nozzle Pressure 60 Pa		Water															
Q (l/s)	Eco HQ	$\Delta tK - 7^{\circ}C$				$\Delta tK - 8^{\circ}C$				$\Delta tK - 9^{\circ}C$				$\Delta tK - 10^{\circ}C$			
		L (m)	P (w)	p(kg/s)	Manifold	p(kPa)	P (w)	p(kg/s)	Manifold	p(kPa)	P (w)	p(kg/s)	Manifold	p(kPa)	P (w)	p(kg/s)	Manifold
10	1.2	403	0.032	C2	4.1	475	0.038	C2	5.4	546	0.043	C2	6.9	618	0.048	C2	8.5
	1.8	513	0.041	C2	9.3	596	0.047	C2	12.1	680	0.054	C2	15.2	771	0.061	C2	18.6
	2.4	-	-	-	-	-	-	-	-	-	-	-	-	-	-	-	-
	3.0	-	-	-	-	-	-	-	-	-	-	-	-	-	-	-	-
	3.6	-	-	-	-	-	-	-	-	-	-	-	-	-	-	-	-
20	1.2	557	0.044	C2	6.9	654	0.052	C2	9.2	747	0.059	C2	11.7	839	0.067	C2	14.4
	1.8	795	0.063	C2	19.1	841	0.067	C3	7.7	969	0.077	C3	9.9	1101	0.088	C3	12.2
	2.4	866	0.069	C3	11.0	1012	0.081	C3	14.3	1174	0.093	C3	18.1	1236	0.098	C4	9.3
	3.0	981	0.078	C3	17.1	1085	0.086	C4	9.3	1240	0.099	C4	11.7	1401	0.112	C4	14.4
	3.6	1027	0.082	C4	10.2	1192	0.095	C4	13.2	1361	0.108	C4	16.5	1478	0.118	C5	10.4
30	1.2	-	-	-	-	-	-	-	-	-	-	-	-	-	-	-	-
	1.8	835	0.066	C3	7.5	981	0.078	C3	10.0	1121	0.089	C3	12.7	1258	0.100	C3	15.7
	2.4	1083	0.086	C3	15.9	1186	0.094	C4	8.5	1365	0.109	C4	10.8	1551	0.123	C4	13.4
	3.0	1190	0.095	C4	10.7	1394	0.111	C4	14.1	1621	0.129	C4	17.8	1727	0.137	C5	11.1
	3.6	1332	0.106	C4	15.7	1484	0.118	C5	10.4	1704	0.136	C5	13.1	1947	0.155	C5	16.2
40	1.2	-	-	-	-	-	-	-	-	-	-	-	-	-	-	-	-
	1.8	-	-	-	-	-	-	-	-	-	-	-	-	-	-	-	-
	2.4	1180	0.094	C3	18.6	1308	0.104	C4	10.0	1494	0.119	C4	12.7	1621	0.129	C5	7.9
	3.0	1368	0.109	C4	13.6	1602	0.128	C4	17.7	1750	0.139	C5	11.3	1985	0.158	C5	14.0
	3.6	1499	0.119	C5	10.4	1759	0.140	C5	13.7	2041	0.162	C5	17.3	2379	0.189	C5	21.6

Flow-adjusted waterside cooling effect table. Cooling circuit $\Delta t = 3^{\circ}C$ (Water in-out), nozzle pressure of 60 Pa, 1 x $\varnothing 125$ air connection.

For green values, a $\varnothing 22$ manifold connection size is required.

Please refer to Frenger Technical Department for selections not covered within these tables.

Cooling only at 80Pa Nozzle Pressure

Nozzle Pressure 80 Pa		Water															
Q (l/s)	Eco HQ	ΔtK - 7 °C				ΔtK - 8 °C				ΔtK - 9 °C				ΔtK - 10 °C			
		L (m)	P (w)	p(kg/s)	Manifold	p(kPa)	P (w)	p(kg/s)	Manifold	p(kPa)	P (w)	p(kg/s)	Manifold	p(kPa)	P (w)	p(kg/s)	Manifold
10	1.2	443	0.035	C2	4.8	522	0.042	C2	6.3	599	0.048	C2	8.0	674	0.054	C2	9.9
	1.8	580	0.046	C2	11.6	667	0.053	C2	14.8	752	0.060	C2	18.4	812	0.065	C3	7.4
	2.4	-	-	-	-	-	-	-	-	-	-	-	-	-	-	-	-
	3.0	-	-	-	-	-	-	-	-	-	-	-	-	-	-	-	-
	3.6	-	-	-	-	-	-	-	-	-	-	-	-	-	-	-	-
20	1.2	586	0.047	C2	7.5	689	0.055	C2	10.0	793	0.063	C2	12.7	906	0.072	C2	15.7
	1.8	773	0.062	C3	6.6	912	0.073	C3	8.8	1049	0.083	C3	11.2	1188	0.095	C3	13.9
	2.4	948	0.075	C3	12.8	1097	0.087	C3	16.6	1198	0.095	C4	8.8	1349	0.107	C4	10.8
	3.0	1038	0.083	C4	8.6	1204	0.096	C4	11.2	1365	0.109	C4	14.0	1527	0.122	C4	17.0
	3.6	1160	0.092	C4	12.6	1333	0.106	C4	16.2	1505	0.120	C4	20.0	1653	0.132	C5	12.8
30	1.2	-	-	-	-	-	-	-	-	-	-	-	-	-	-	-	-
	1.8	878	0.070	C3	8.2	1033	0.082	C3	10.9	1190	0.095	C3	13.9	1359	0.108	C3	17.2
	2.4	1165	0.093	C3	17.9	1276	0.102	C4	9.5	1468	0.117	C4	12.2	1667	0.133	C4	15.1
	3.0	1292	0.103	C4	12.4	1505	0.120	C4	16.1	1653	0.132	C5	10.3	1865	0.148	C5	12.7
	3.6	1446	0.115	C4	18.3	1622	0.129	C5	12.1	1847	0.147	C5	15.2	2080	0.166	C5	18.6
40	1.2	-	-	-	-	-	-	-	-	-	-	-	-	-	-	-	-
	1.8	915	0.073	C3	8.8	1077	0.086	C3	11.6	1243	0.099	C3	14.8	1429	0.114	C3	18.4
	2.4	1171	0.093	C4	8.2	1377	0.110	C4	10.9	1586	0.126	C4	13.9	1812	0.144	C4	17.2
	3.0	1463	0.116	C4	15.1	1719	0.137	C4	19.8	1873	0.149	C5	12.6	2129	0.169	C5	15.6
	3.6	1625	0.129	C5	11.9	1900	0.151	C5	15.6	2191	0.174	C5	19.7	2529	0.201	C5	24.4

Flow-adjusted waterside cooling effect table. Cooling circuit Δt = 3°C (Water in-out), nozzle pressure of 80 Pa, 1 x Ø125 air connection.

For green values, a Ø22 manifold connection size is required.

Please refer to Frenger Technical Department for selections not covered within these tables.

Cooling only at 100Pa Nozzle Pressure

Nozzle Pressure 100 Pa		Water															
Q (l/s)	Eco HQ	ΔtK - 7 °C				ΔtK - 8 °C				ΔtK - 9 °C				ΔtK - 10 °C			
		L (m)	P (w)	p(kg/s)	Manifold	p(kPa)	P (w)	p(kg/s)	Manifold	p(kPa)	P (w)	p(kg/s)	Manifold	p(kPa)	P (w)	p(kg/s)	Manifold
10	1.2	470	0.037	C2	5.2	553	0.044	C2	6.9	634	0.050	C2	8.8	712	0.057	C2	10.9
	1.8	615	0.049	C2	12.8	708	0.056	C2	16.4	765	0.061	C3	6.7	862	0.069	C3	8.2
	2.4	-	-	-	-	-	-	-	-	-	-	-	-	-	-	-	-
	3.0	-	-	-	-	-	-	-	-	-	-	-	-	-	-	-	-
	3.6	-	-	-	-	-	-	-	-	-	-	-	-	-	-	-	-
20	1.2	639	0.051	C2	8.7	751	0.060	C2	11.5	865	0.069	C2	14.6	990	0.079	C2	18.1
	1.8	822	0.065	C3	7.3	967	0.077	C3	9.7	1109	0.088	C3	12.4	1254	0.100	C3	15.3
	2.4	1002	0.080	C3	14.1	1159	0.092	C3	18.3	1267	0.101	C4	9.6	1424	0.113	C4	11.9
	3.0	1098	0.087	C4	9.4	1273	0.101	C4	12.3	1443	0.115	C4	15.4	1616	0.129	C4	18.7
	3.6	1231	0.098	C4	14.0	1415	0.113	C4	17.9	1571	0.125	C5	11.6	1755	0.140	C5	14.1
30	1.2	679	0.054	C2	9.6	798	0.063	C2	12.7	924	0.074	C2	16.2	940	0.075	C3	6.1
	1.8	958	0.076	C3	9.4	1126	0.090	C3	12.5	1298	0.103	C3	16.0	1485	0.118	C3	19.8
	2.4	1240	0.099	C3	19.9	1361	0.108	C4	10.7	1564	0.124	C4	13.6	1774	0.141	C4	16.8
	3.0	1367	0.109	C4	13.6	1589	0.127	C4	17.7	1747	0.139	C5	11.3	1970	0.157	C5	14.0
	3.6	1476	0.117	C5	10.2	1714	0.136	C5	13.3	1950	0.155	C5	16.7	2199	0.175	C5	20.4
40	1.2	-	-	-	-	-	-	-	-	-	-	-	-	-	-	-	-
	1.8	1007	0.080	C3	10.3	1184	0.094	C3	13.6	1369	0.109	C3	17.4	1443	0.115	C4	8.7
	2.4	1278	0.102	C4	9.4	1502	0.120	C4	12.5	1731	0.138	C4	16.0	1981	0.158	C4	19.8
	3.0	1569	0.125	C4	17.0	1747	0.139	C5	11.1	2008	0.160	C5	14.2	2282	0.182	C5	17.5
	3.6	1721	0.137	C5	13.1	2007	0.160	C5	17.2	2312	0.184	C5	21.7	2671	0.213	C5	26.7

Flow-adjusted waterside cooling effect table. Cooling circuit Δt = 3°C (Water in-out), nozzle pressure of 100 Pa, 1 x Ø125 air connection.

For green values, a Ø22 manifold connection size is required.

Please refer to Frenger Technical Department for selections not covered within these tables.

Cooling & Heating at 40Pa Nozzle Pressure

Nozzle Pressure 40 Pa		Water															
Q (l/s)	Eco HQ	ΔTK - 7 °C				ΔTK - 8 °C				ΔTK - 9 °C				ΔTK - 10 °C			
		L (m)	P (w)	p(kg/s)	Manifold	p(kPa)	P (w)	p(kg/s)	Manifold	p(kPa)	P (w)	p(kg/s)	Manifold	p(kPa)	P (w)	p(kg/s)	Manifold
10	1.2	321	0.026	C2	2.5	381	0.030	C2	3.4	440	0.035	C2	4.3	498	0.040	C2	5.4
	1.8	423	0.034	C2	6.1	493	0.039	C2	7.9	565	0.045	C2	10.0	639	0.051	C2	12.3
	2.4	481	0.038	C2	10.1	560	0.045	C2	13.1	642	0.051	C2	16.6	671	0.053	C3	6.3
	3.0	519	0.041	C2	14.5	604	0.048	C2	18.7	642	0.051	C3	7.3	725	0.058	C3	8.9
	3.6	-	-	-	-	-	-	-	-	-	-	-	-	-	-	-	-
20	1.2	-	-	-	-	-	-	-	-	-	-	-	-	-	-	-	-
	1.8	608	0.048	C2	11.2	715	0.057	C2	14.6	841	0.067	C2	18.6	846	0.067	C3	6.9
	2.4	698	0.056	C3	6.7	815	0.065	C3	8.7	937	0.075	C3	11.0	1074	0.085	C3	13.6
	3.0	809	0.064	C3	10.8	946	0.075	C3	14.0	1100	0.088	C3	17.8	1155	0.092	C4	8.6
	3.6	895	0.071	C3	15.4	1052	0.084	C3	20.0	1130	0.090	C4	10.0	1279	0.102	C4	12.3
30	1.2	-	-	-	-	-	-	-	-	-	-	-	-	-	-	-	-
	1.8	-	-	-	-	-	-	-	-	-	-	-	-	-	-	-	-
	2.4	820	0.065	C3	8.6	960	0.076	C3	11.4	1106	0.088	C3	14.4	1267	0.101	C3	17.8
	3.0	999	0.079	C3	15.2	1196	0.095	C3	19.9	1257	0.100	C4	9.9	1436	0.114	C4	12.2
	3.6	1073	0.085	C4	9.1	1256	0.100	C4	11.9	1464	0.117	C4	15.1	1732	0.138	C4	18.9
40	1.2	-	-	-	-	-	-	-	-	-	-	-	-	-	-	-	-
	1.8	-	-	-	-	-	-	-	-	-	-	-	-	-	-	-	-
	2.4	-	-	-	-	-	-	-	-	-	-	-	-	-	-	-	-
	3.0	1096	0.087	C3	17.8	1205	0.096	C4	9.1	1383	0.110	C4	11.6	1567	0.125	C4	14.3
	3.6	1216	0.097	C4	11.2	1430	0.114	C4	14.6	1681	0.134	C4	18.6	1771	0.141	C5	11.5

Flow-adjusted waterside cooling effect table. Cooling circuit Δt = 3°C (Water in-out), nozzle pressure of 40 Pa, 1 x Ø125 air connection.

For green values, a Ø22 manifold connection size is required.

Please refer to Frenger Technical Department for selections not covered within these tables.

Cooling & Heating at 60Pa Nozzle Pressure

Nozzle Pressure 60 Pa		Water															
Q (l/s)	Eco HQ	ΔTK - 7 °C				ΔTK - 8 °C				ΔTK - 9 °C				ΔTK - 10 °C			
		L (m)	P (w)	p(kg/s)	Manifold	p(kPa)	P (w)	p(kg/s)	Manifold	p(kPa)	P (w)	p(kg/s)	Manifold	p(kPa)	P (w)	p(kg/s)	Manifold
10	1.2	344	0.027	C2	2.8	409	0.033	C2	3.8	473	0.038	C2	4.9	537	0.043	C2	6.1
	1.8	446	0.036	C2	6.6	520	0.041	C2	8.7	594	0.047	C2	10.9	669	0.053	C2	13.4
	2.4	-	-	-	-	-	-	-	-	-	-	-	-	-	-	-	-
	3.0	-	-	-	-	-	-	-	-	-	-	-	-	-	-	-	-
	3.6	-	-	-	-	-	-	-	-	-	-	-	-	-	-	-	-
20	1.2	476	0.038	C2	4.8	566	0.045	C2	6.4	652	0.052	C2	8.3	735	0.058	C2	10.3
	1.8	684	0.054	C2	13.6	808	0.064	C2	17.8	838	0.067	C3	6.7	952	0.076	C3	8.4
	2.4	751	0.060	C3	7.5	878	0.070	C3	9.8	1009	0.080	C3	12.4	1151	0.092	C3	15.4
	3.0	855	0.068	C3	11.8	995	0.079	C3	15.3	1147	0.091	C3	19.3	1219	0.097	C4	9.5
	3.6	939	0.075	C3	16.8	1041	0.083	C4	8.7	1188	0.095	C4	10.9	1338	0.106	C4	13.4
30	1.2	-	-	-	-	-	-	-	-	-	-	-	-	-	-	-	-
	1.8	788	0.063	C2	17.5	848	0.068	C3	6.8	978	0.078	C3	8.7	1102	0.088	C3	10.8
	2.4	938	0.075	C3	10.8	1099	0.088	C3	14.2	1273	0.101	C3	18.0	1341	0.107	C4	8.7
	3.0	1105	0.088	C3	17.9	1207	0.096	C4	9.2	1389	0.111	C4	11.7	1589	0.126	C4	14.4
	3.6	1156	0.092	C4	10.3	1351	0.108	C4	13.4	1568	0.125	C4	17.0	1674	0.133	C5	10.6
40	1.2	-	-	-	-	-	-	-	-	-	-	-	-	-	-	-	-
	1.8	-	-	-	-	-	-	-	-	-	-	-	-	-	-	-	-
	2.4	1032	0.082	C3	12.8	1196	0.095	C3	16.7	1304	0.104	C4	8.3	1470	0.117	C4	10.3
	3.0	1185	0.094	C4	8.8	1388	0.110	C4	11.6	1597	0.127	C4	14.7	1827	0.145	C4	18.2
	3.6	1369	0.109	C4	13.6	1616	0.129	C4	17.8	1752	0.139	C5	11.3	2001	0.159	C5	14.0

Flow-adjusted waterside cooling effect table. Cooling circuit Δt = 3°C (Water in-out), nozzle pressure of 60 Pa, 1 x Ø125 air connection.

For green values, a Ø22 manifold connection size is required.

Please refer to Frenger Technical Department for selections not covered within these tables.

Cooling & Heating at 80Pa Nozzle Pressure

Nozzle Pressure 80 Pa		Water															
Q (l/s)	Eco HQ	ΔtK - 7 °C				ΔtK - 8 °C				ΔtK - 9 °C				ΔtK - 10 °C			
		L (m)	P (w)	p(kg/s)	Manifold	p(kPa)	P (w)	p(kg/s)	Manifold	p(kPa)	P (w)	p(kg/s)	Manifold	p(kPa)	P (w)	p(kg/s)	Manifold
10	1.2	378	0.030	C2	3.3	450	0.036	C2	4.4	521	0.041	C2	5.7	589	0.047	C2	7.1
	1.8	508	0.040	C2	8.3	588	0.047	C2	10.8	665	0.053	C2	13.4	741	0.059	C2	16.3
	2.4	-	-	-	-	-	-	-	-	-	-	-	-	-	-	-	-
	3.0	-	-	-	-	-	-	-	-	-	-	-	-	-	-	-	-
	3.6	-	-	-	-	-	-	-	-	-	-	-	-	-	-	-	-
20	1.2	501	0.040	C2	5.2	595	0.047	C2	7.0	686	0.055	C2	9.0	779	0.062	C2	11.2
	1.8	740	0.059	C2	15.5	785	0.062	C3	5.9	909	0.072	C3	7.7	1030	0.082	C3	9.5
	2.4	826	0.066	C3	8.8	961	0.076	C3	11.5	1094	0.087	C3	14.5	1231	0.098	C3	17.7
	3.0	947	0.075	C3	14.2	1090	0.087	C3	18.2	1200	0.096	C4	9.3	1344	0.107	C4	11.3
	3.6	1015	0.081	C4	8.3	1175	0.094	C4	10.8	1329	0.106	C4	13.4	1482	0.118	C4	16.3
30	1.2	-	-	-	-	-	-	-	-	-	-	-	-	-	-	-	-
	1.8	842	0.067	C2	19.1	892	0.071	C3	7.4	1029	0.082	C3	9.5	1168	0.093	C3	11.8
	2.4	1009	0.080	C3	12.2	1182	0.094	C3	16.0	1271	0.101	C4	7.9	1442	0.115	C4	9.8
	3.0	1121	0.089	C4	8.0	1311	0.104	C4	10.6	1500	0.119	C4	13.4	1698	0.135	C4	16.4
	3.6	1266	0.101	C4	12.1	1465	0.117	C4	15.6	1673	0.133	C4	19.5	1817	0.145	C5	12.3
40	1.2	-	-	-	-	-	-	-	-	-	-	-	-	-	-	-	-
	1.8	785	0.062	C3	5.9	929	0.074	C3	7.9	1073	0.085	C3	10.1	1220	0.097	C3	12.6
	2.4	1089	0.087	C3	13.9	1280	0.102	C3	18.2	1372	0.109	C4	9.0	1558	0.124	C4	11.2
	3.0	1267	0.101	C4	9.8	1485	0.118	C4	12.9	1713	0.136	C4	16.4	1840	0.146	C5	10.2
	3.6	1480	0.118	C4	15.5	1648	0.131	C5	10.2	1893	0.151	C5	12.9	2150	0.171	C5	16.0

Flow-adjusted waterside cooling effect table. Cooling circuit Δt = 3°C (Water in-out), nozzle pressure of 80 Pa, 1 x Ø125 air connection.

For green values, a Ø22 manifold connection size is required.

Please refer to Frenger Technical Department for selections not covered within these tables.

Cooling & Heating at 100Pa Nozzle Pressure

Nozzle Pressure 100 Pa		Water															
Q (l/s)	Eco HQ	ΔtK - 7 °C				ΔtK - 8 °C				ΔtK - 9 °C				ΔtK - 10 °C			
		L (m)	P (w)	p(kg/s)	Manifold	p(kPa)	P (w)	p(kg/s)	Manifold	p(kPa)	P (w)	p(kg/s)	Manifold	p(kPa)	P (w)	p(kg/s)	Manifold
10	1.2	401	0.032	C2	3.7	477	0.038	C2	4.9	551	0.044	C2	6.3	623	0.050	C2	7.8
	1.8	539	0.043	C2	9.2	623	0.050	C2	11.9	705	0.056	C2	14.9	788	0.063	C2	18.0
	2.4	-	-	-	-	-	-	-	-	-	-	-	-	-	-	-	-
	3.0	-	-	-	-	-	-	-	-	-	-	-	-	-	-	-	-
	3.6	-	-	-	-	-	-	-	-	-	-	-	-	-	-	-	-
20	1.2	547	0.044	C2	6.0	649	0.052	C2	8.1	748	0.060	C2	10.4	850	0.068	C2	12.9
	1.8	782	0.062	C2	17.1	835	0.066	C3	6.6	964	0.077	C3	8.5	1090	0.087	C3	10.5
	2.4	874	0.070	C3	9.7	1015	0.081	C3	12.7	1155	0.093	C3	15.9	1302	0.104	C3	19.4
	3.0	1001	0.080	C3	15.6	1153	0.092	C3	20.0	1269	0.101	C4	10.2	1421	0.113	C4	12.5
	3.6	1078	0.086	C4	9.2	1247	0.099	C4	11.9	1411	0.112	C4	14.9	1576	0.125	C4	18.0
30	1.2	582	0.046	C2	6.7	689	0.055	C2	8.9	795	0.063	C2	11.5	906	0.072	C2	14.3
	1.8	821	0.065	C3	6.3	973	0.077	C3	8.5	1122	0.089	C3	10.9	1274	0.101	C3	13.6
	2.4	1076	0.086	C3	13.6	1258	0.100	C3	17.9	1357	0.108	C4	8.8	1537	0.122	C4	11.0
	3.0	1188	0.095	C4	8.9	1386	0.110	C4	11.6	1584	0.126	C4	14.7	1793	0.143	C4	18.1
	3.6	1337	0.106	C4	13.3	1547	0.123	C4	17.2	1708	0.136	C5	11.0	1918	0.153	C5	13.5
40	1.2	-	-	-	-	-	-	-	-	-	-	-	-	-	-	-	-
	1.8	865	0.069	C3	6.9	1023	0.081	C3	9.2	1180	0.094	C3	11.8	1343	0.107	C3	14.7
	2.4	1188	0.095	C3	16.0	1297	0.103	C4	8.1	1497	0.119	C4	10.4	1699	0.135	C4	12.9
	3.0	1360	0.108	C4	11.0	1592	0.127	C4	14.6	1836	0.146	C4	18.4	1973	0.157	C5	11.5
	3.6	1564	0.124	C4	17.1	1746	0.139	C5	11.2	2000	0.159	C5	14.2	2269	0.181	C5	17.5

Flow-adjusted waterside cooling effect table. Cooling circuit Δt = 3°C (Water in-out), nozzle pressure of 100 Pa, 1 x Ø125 air connection.

For green values, a Ø22 manifold connection size is required.

Please refer to Frenger Technical Department for selections not covered within these tables.

Heating Selection Tables

Heating at 40Pa Nozzle Pressure

Nozzle Pressure 40 Pa		Water											
Q (l/s)	Eco HQ	ΔtK - 15°C			ΔtK - 20°C			ΔtK - 25°C			ΔtK - 30°C		
		L (m)	P (w)	p(kg/s)	p(kPa)	P (w)	p(kg/s)	p(kPa)	P (w)	p(kg/s)	p(kPa)	P (w)	p(kg/s)
10	1.2	296	0.012	0.4	373	0.012	0.4	442	0.012	0.4	541	0.013	0.5
	1.8	354	0.012	0.6	441	0.012	0.6	561	0.013	0.9	693	0.017	1.3
	2.4	417	0.012	1.1	516	0.012	1.0	665	0.016	1.6	817	0.020	2.3
	3.0	451	0.012	1.2	591	0.014	1.6	759	0.018	2.5	930	0.022	3.6
	3.6	451	0.012	1.5	591	0.014	2.0	759	0.018	3.0	930	0.022	4.3
20	1.2	-	-	-	-	-	-	-	-	-	-	-	-
	1.8	453	0.012	0.6	629	0.015	1.1	823	0.020	1.7	1017	0.024	2.5
	2.4	541	0.013	1.1	762	0.018	2.0	986	0.024	3.2	1209	0.029	4.5
	3.0	623	0.015	1.8	869	0.021	3.2	1116	0.027	4.9	1362	0.033	7.0
	3.6	693	0.017	2.6	961	0.023	4.6	1229	0.029	7.0	1494	0.036	9.9
30	1.2	-	-	-	-	-	-	-	-	-	-	-	-
	1.8	-	-	-	-	-	-	-	-	-	-	-	-
	2.4	664	0.016	1.6	936	0.022	2.9	1207	0.029	4.5	1472	0.035	6.4
	3.0	780	0.019	2.6	1088	0.026	4.7	1391	0.033	7.3	1689	0.040	10.2
	3.6	874	0.021	3.9	1209	0.029	6.8	1539	0.037	10.4	1864	0.045	14.6
40	1.2	-	-	-	-	-	-	-	-	-	-	-	-
	1.8	-	-	-	-	-	-	-	-	-	-	-	-
	2.4	-	-	-	-	-	-	-	-	-	-	-	-
	3.0	891	0.021	3.3	1237	0.030	5.9	1575	0.038	9.0	1907	0.046	12.6
	3.6	1017	0.024	5.1	1400	0.034	8.8	1774	0.042	13.4	-	-	-

Flow-adjusted waterside heating effect table. Heating circuit Δt = 10°C (Water in-out), nozzle pressure of 40 Pa, 1 x Ø125 air connection.
For red values, the flow rate has been adjusted to the recommended minimum flow of 0.012 kg/s.

Heating at 60Pa Nozzle Pressure

Nozzle Pressure 60 Pa		Water											
Q (l/s)	Eco HQ	ΔtK - 15°C			ΔtK - 20°C			ΔtK - 25°C			ΔtK - 30°C		
		L (m)	P (w)	p(kg/s)	p(kPa)	P (w)	p(kg/s)	p(kPa)	P (w)	p(kg/s)	p(kPa)	P (w)	p(kg/s)
10	1.2	314	0.012	0.5	390	0.012	0.4	459	0.012	0.4	573	0.014	0.6
	1.8	372	0.012	0.7	467	0.012	0.7	597	0.014	1.0	739	0.018	1.4
	2.4	429	0.012	1.0	542	0.013	1.1	703	0.017	1.7	865	0.021	2.5
	3.0	429	0.012	1.3	544	0.013	1.4	704	0.017	2.2	866	0.021	3.2
	3.6	429	0.012	1.6	544	0.013	1.7	704	0.017	2.7	866	0.021	3.8
20	1.2	381	0.012	0.4	473	0.012	0.4	630	0.015	0.7	791	0.019	1.0
	1.8	470	0.012	0.6	670	0.016	1.2	875	0.021	1.9	1079	0.026	2.7
	2.4	573	0.014	1.2	808	0.019	2.2	1043	0.025	3.5	1277	0.031	5.0
	3.0	661	0.016	2.0	922	0.022	3.5	1182	0.028	5.5	1439	0.034	7.7
	3.6	739	0.018	2.9	1024	0.025	5.1	1306	0.031	7.8	1584	0.038	11.0
30	1.2	-	-	-	-	-	-	-	-	-	-	-	-
	1.8	551	0.013	0.8	791	0.019	1.6	1032	0.025	2.5	1271	0.030	3.6
	2.4	710	0.017	1.8	998	0.024	3.2	1284	0.031	5.0	1564	0.037	7.1
	3.0	828	0.020	2.9	1151	0.028	5.2	1469	0.035	8.0	1781	0.043	11.2
	3.6	926	0.022	4.3	1277	0.031	7.5	1621	0.039	11.4	1961	0.047	16.0
40	1.2	-	-	-	-	-	-	-	-	-	-	-	-
	1.8	-	-	-	-	-	-	-	-	-	-	-	-
	2.4	791	0.019	2.1	1112	0.027	3.9	1427	0.034	6.0	1736	0.042	8.5
	3.0	953	0.023	3.7	1320	0.032	6.6	1679	0.040	10.1	2034	0.049	14.1
	3.6	1079	0.026	5.6	1481	0.035	9.8	1876	0.045	14.8	-	-	-

Flow-adjusted waterside heating effect table. Heating circuit Δt = 10°C (Water in-out), nozzle pressure of 60 Pa, 1 x Ø125 air connection.
For red values, the flow rate has been adjusted to the recommended minimum flow of 0.012 kg/s.

Heating at 80Pa Nozzle Pressure

Nozzle Pressure 80 Pa		Water											
Q (l/s)	Eco HQ	ΔtK - 15°C			ΔtK - 20°C			ΔtK - 25°C			ΔtK - 30°C		
		L (m)	P (w)	p(kg/s)	p(kPa)	P (w)	p(kg/s)	p(kPa)	P (w)	p(kg/s)	p(kPa)	P (w)	p(kg/s)
10	1.2	325	0.012	0.4	417	0.012	0.5	485	0.012	0.4	607	0.015	0.7
	1.8	388	0.012	0.7	484	0.012	0.7	633	0.015	1.1	785	0.019	1.6
	2.4	424	0.012	1.1	530	0.013	1.1	691	0.017	1.7	853	0.020	2.5
	3.0	424	0.012	1.3	530	0.013	1.3	691	0.017	2.1	853	0.020	3.1
	3.6	424	0.012	1.6	530	0.013	1.6	691	0.017	2.6	853	0.020	3.7
20	1.2	405	0.012	0.5	515	0.012	0.5	685	0.016	0.8	858	0.021	1.2
	1.8	500	0.012	0.7	712	0.017	1.3	927	0.022	2.1	1142	0.027	3.0
	2.4	607	0.015	1.3	854	0.020	2.5	1101	0.026	3.8	1344	0.032	5.4
	3.0	699	0.017	2.2	976	0.023	3.9	1248	0.030	6.0	1515	0.036	8.4
	3.6	785	0.019	3.2	1087	0.026	5.7	1382	0.033	8.6	1671	0.040	12.1
30	1.2	-	-	-	-	-	-	-	-	-	-	-	-
	1.8	599	0.014	1.0	858	0.021	1.8	1119	0.027	2.9	1376	0.033	4.2
	2.4	756	0.018	2.0	1061	0.025	3.6	1362	0.033	5.6	1658	0.040	7.8
	3.0	876	0.021	3.2	1214	0.029	5.7	1546	0.037	8.7	1874	0.045	12.2
	3.6	978	0.023	4.7	1344	0.032	8.2	1702	0.041	12.4	-	-	-
40	1.2	-	-	-	-	-	-	-	-	-	-	-	-
	1.8	636	0.015	1.1	922	0.022	2.1	1207	0.029	3.3	1486	0.036	4.8
	2.4	858	0.021	2.5	1205	0.029	4.5	1544	0.037	6.9	1877	0.045	9.7
	3.0	1016	0.024	4.2	1404	0.034	7.4	1785	0.043	11.2	-	-	-
	3.6	1142	0.027	6.2	1563	0.037	10.7	1981	0.047	16.2	-	-	-

Flow-adjusted waterside heating effect table. Heating circuit Δt = 10°C (Water in-out), nozzle pressure of 80 Pa, 1 x Ø125 air connection.
For red values, the flow rate has been adjusted to the recommended minimum flow of 0.012 kg/s.

Heating at 100Pa Nozzle Pressure

Nozzle Pressure 100 Pa		Water											
Q (l/s)	Eco HQ	ΔtK - 15°C			ΔtK - 20°C			ΔtK - 25°C			ΔtK - 30°C		
		L (m)	P (w)	p(kg/s)	p(kPa)	P (w)	p(kg/s)	p(kPa)	P (w)	p(kg/s)	p(kPa)	P (w)	p(kg/s)
10	1.2	329	0.012	0.4	422	0.012	0.5	495	0.012	0.5	618	0.015	0.7
	1.8	395	0.012	0.7	496	0.012	0.7	649	0.016	1.1	805	0.019	1.6
	2.4	397	0.012	0.9	499	0.012	1.0	653	0.016	1.5	810	0.019	2.2
	3.0	397	0.012	1.2	499	0.012	1.2	653	0.016	1.9	810	0.019	2.8
	3.6	397	0.012	1.4	499	0.012	1.5	653	0.016	2.3	810	0.019	3.4
20	1.2	428	0.012	0.5	539	0.013	0.5	713	0.017	0.9	889	0.021	1.3
	1.8	511	0.012	0.7	726	0.017	1.4	944	0.023	2.2	1161	0.028	3.1
	2.4	618	0.015	1.4	870	0.021	2.5	1121	0.027	4.0	1369	0.033	5.6
	3.0	714	0.017	2.3	997	0.024	4.1	1277	0.031	6.2	1551	0.037	8.8
	3.6	805	0.019	3.4	1117	0.027	6.0	1422	0.034	9.1	1722	0.041	12.7
30	1.2	449	0.012	0.5	599	0.014	0.6	802	0.019	1.1	1007	0.024	1.6
	1.8	626	0.015	1.1	889	0.021	2.0	1154	0.028	3.1	1414	0.034	4.4
	2.4	774	0.019	2.1	1081	0.026	3.7	1385	0.033	5.7	1683	0.040	8.0
	3.0	891	0.021	3.3	1234	0.030	5.9	1570	0.038	9.0	1902	0.046	12.5
	3.6	996	0.024	4.9	1369	0.033	8.5	1734	0.042	12.9	-	-	-
40	1.2	-	-	-	-	-	-	-	-	-	-	-	-
	1.8	686	0.016	1.2	984	0.024	2.3	1280	0.031	3.7	1568	0.038	5.3
	2.4	889	0.021	2.6	1241	0.030	4.7	1585	0.038	7.2	1922	0.046	10.2
	3.0	1038	0.025	4.3	1429	0.034	7.6	1813	0.043	11.5	-	-	-
	3.6	1161	0.028	6.4	1587	0.038	11.0	2007	0.048	16.6	-	-	-

Flow-adjusted waterside heating effect table. Heating circuit Δt = 10°C (Water in-out), nozzle pressure of 100 Pa, 1 x Ø125 air connection.
For red values, the flow rate has been adjusted to the recommended minimum flow of 0.012 kg/s.

Air Cooling Effect

Cooling effect supplied in the ventilation air [W]

1. Start by calculating the required cooling effect that has to be supplied to the room in order to provide a certain temperature.
2. Calculate any cooling effect that is provided by the ventilation.
3. The remaining cooling effect has to be supplied by the beam.

Formula for air cooling effect: $P = m \cdot C_p \cdot \Delta t$

Where:

m = mass

C_p = specific heat capacity [J/(kg·K)]

q_p = air flow [l/s]

Δt = the difference between the temperature of the room and the temperature of the supply air [K].

It is usually $m \cdot C_p \approx q_p \cdot 1.2$

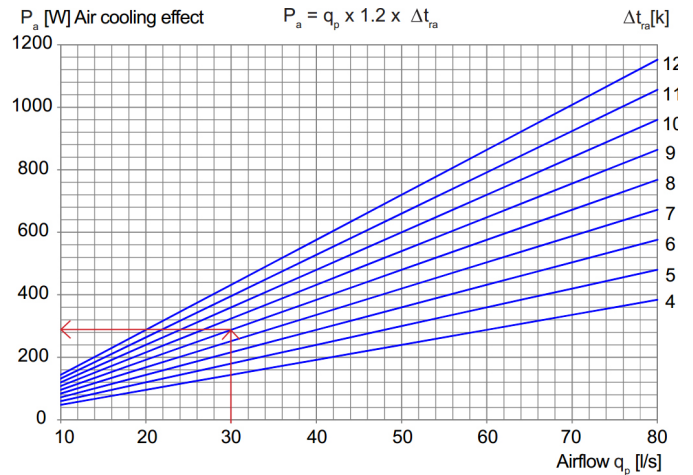

Air cooling effect as a function of airflow. For example, if the air flow is 30 l/s and the under-temperature of the supply air is $\Delta t_{ra} = 8K$, the cooling effect from the graph is 290W.

Scatter Diagram

Fresh Air Volume 22 l / s / Active m @ 80 Pa

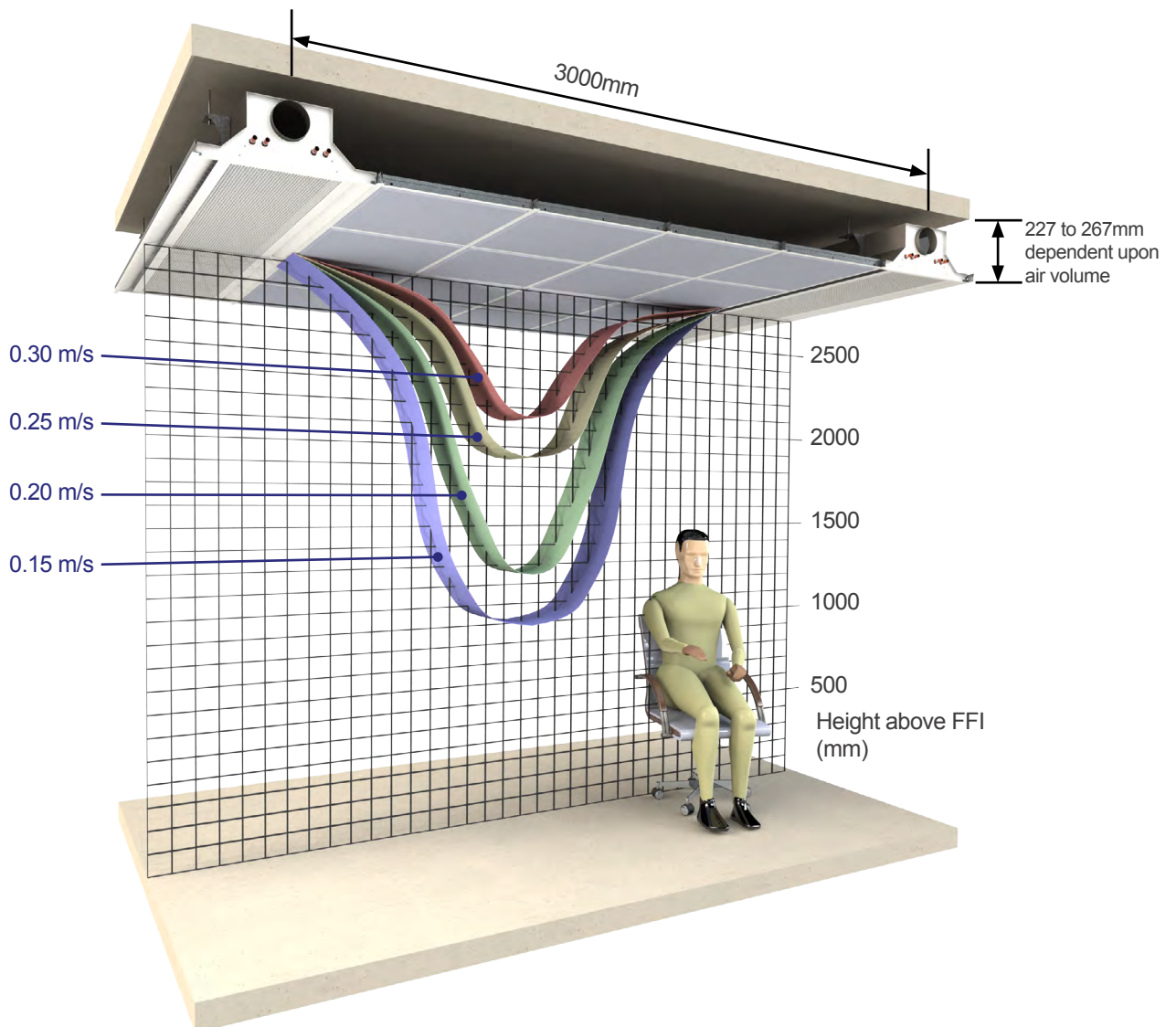

Product Dimensions

Eco HQ 125

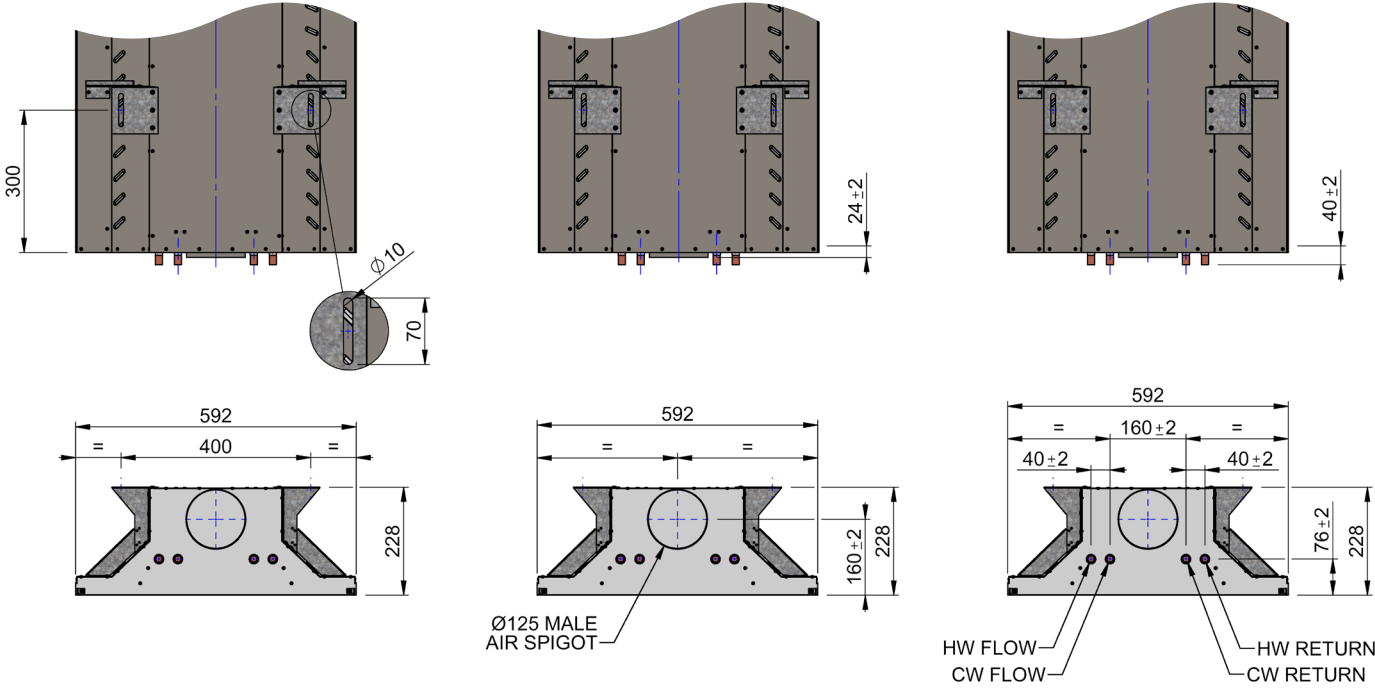

Mounting Details

Eco HQ 125

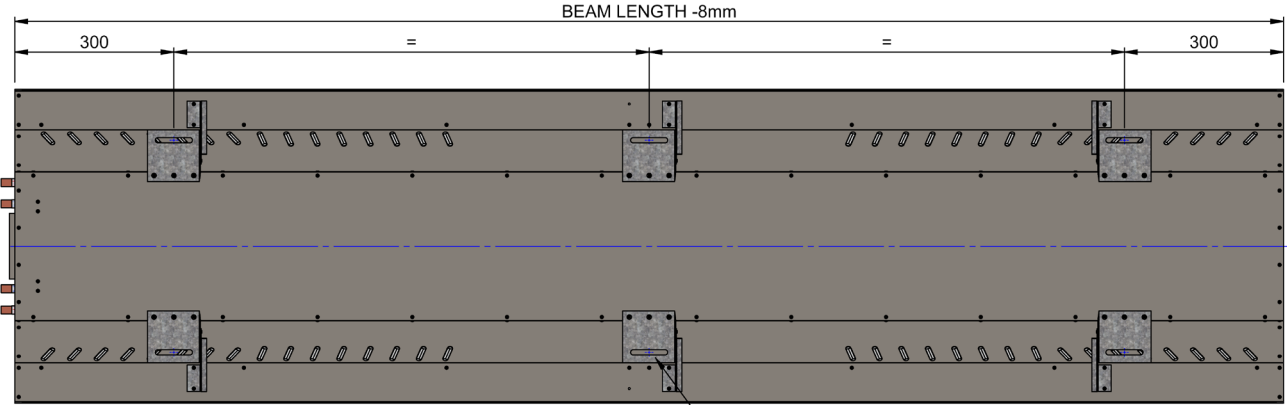

NOTE: BEAM LENGTHS LESS THAN OR EQUAL TO 1.8m HAVE NO CENTRAL SUPPORT BRACKETS

Eco HQ 160

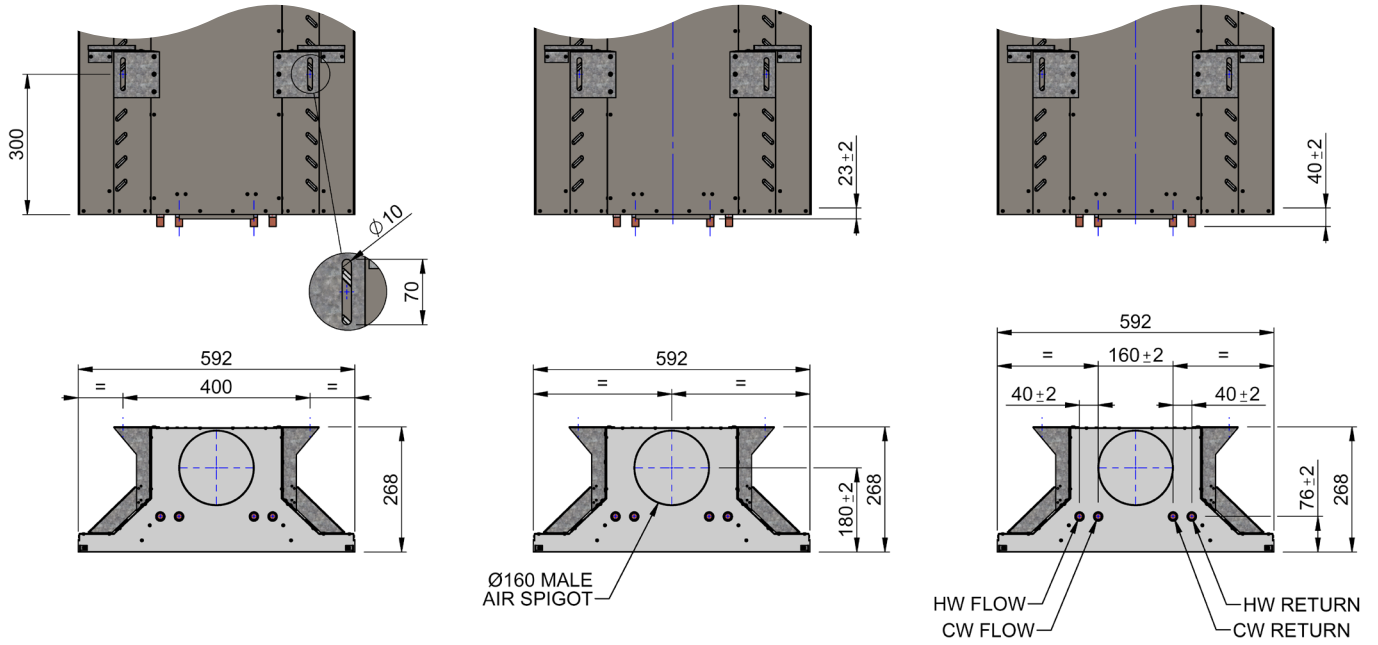

Mounting Details

Eco HQ 160

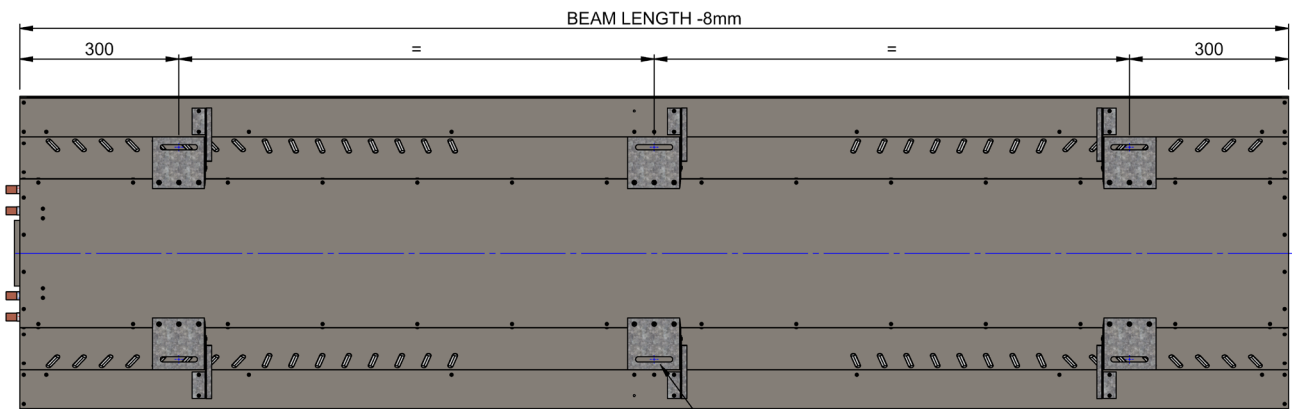

Lighting Options

Integrated Lighting

Lighting can be integrated into Frenger's Eco HQ Chilled Beam to provide a 100% downlight solution. There are different lighting options that can be integrated, which include: T5 and LED all with numerous optic solutions such as louvre as illustrated, MMP Diffusers etc.

All lighting factory fitted by Frenger are 100% tested for electrical safety and functionality in accordance with BS EN 60598-1 prior to packaging and dispatch of the Eco HQ Chilled Beam unit.

Tests include:

- Earth Continuity Test.
- Insulation Resistance Test.
- Polarity Check.
- Function Test.

For full lighting possibilities and performances for the Eco HQ Chilled Beam with integrated lighting, please contact Frenger's technical department.



Perforation Pattern Options



Slot Perforation
43% Free Area

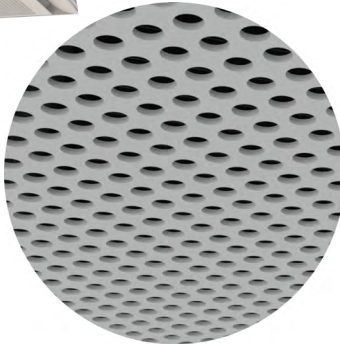

Dot Perforation
33% Free Area



Double Dot Perforation
51% Free Area

Product Ordering Codes

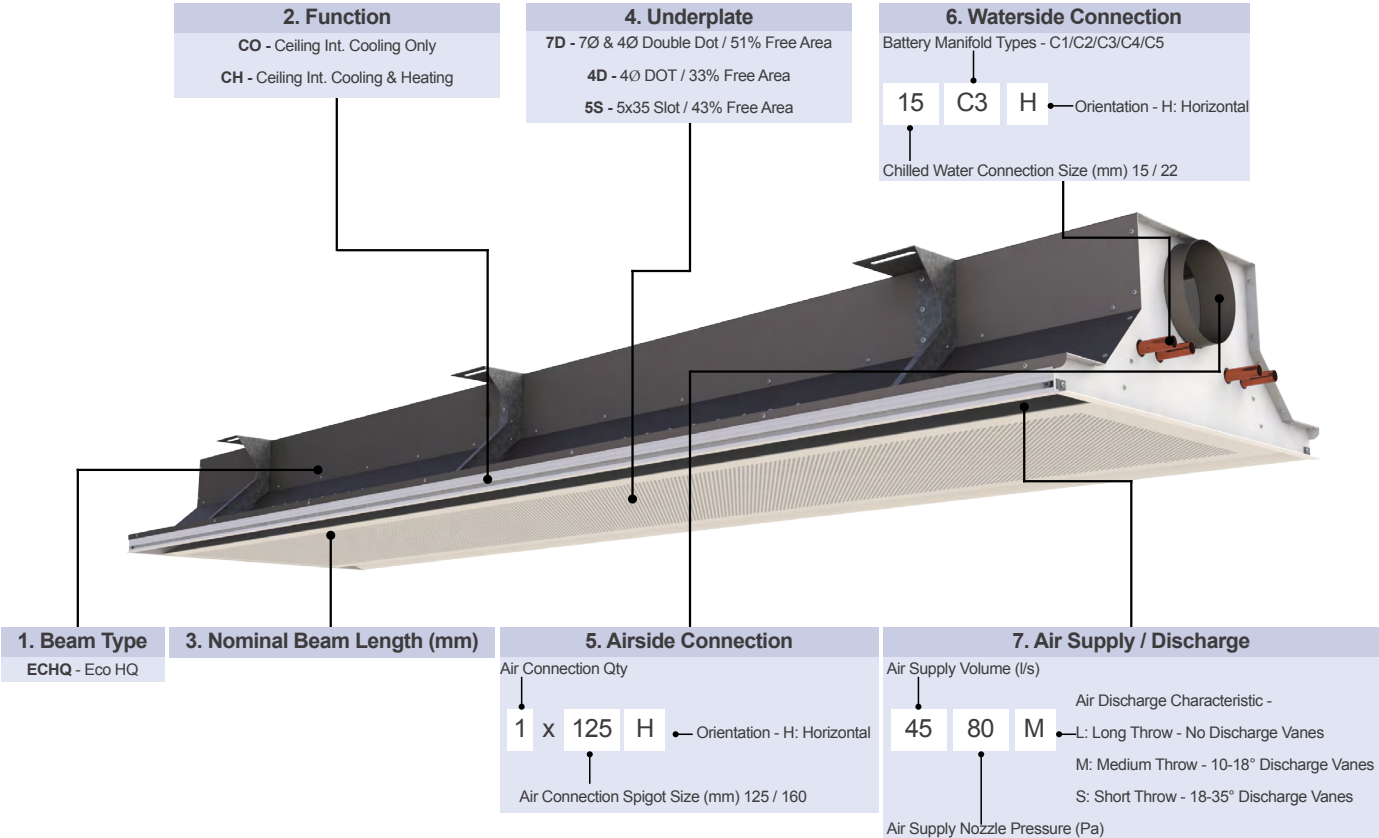

Example: ECHQ CH 2400 7D - 1 x 100H 15C3H - 4580M

↑
↑
↑
↑
↑
↑
↑
↑

Calculation Program

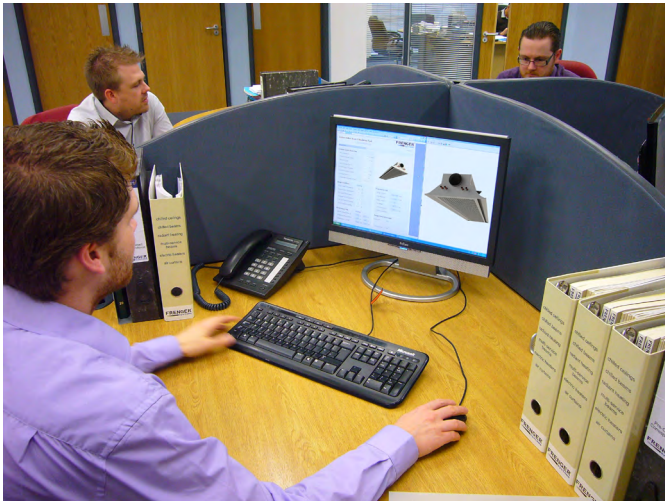

Eco Active Beam Data

Beam Variant	Standard
Air Connection	1x125 mm
Product Overall Length	2.4 m
Manifold Type	C3
Air Discharge Throw	S
Nozzle Static Pressure	10020 Pa
Fresh Air Supply Volume	H4 l/s
Heating Function	51% OBR
Underplate Perforation Type	

Frenger's calculation programme for Eco HQ is extremely user friendly.

Simply select from the drop down menu the "Air Connection" configuration. Air volumes in excess of 40 ltrs/sec and up to 50 ltrs/sec should be 2 x 80 diameter.

"Manifold Types" can be changed in the drop down menu for increased waterside cooling effect, however attention needs to be taken regarding resultant pressure drops (hydraulic resistance), If pressure drops need reducing, choose a higher numbered manifold (C5 being the highest and C2 being the lowest).

"Discharge Throw" can be S (short), M (medium) or L (long).

"Underplate Perforated" options can be found on page 16.

Active Chilled Beam Calculation Tool

[Is this the latest version?](#)

version 1.3.2HQ

Beam Ref. / Selection ID

Eco Active Beam Data

Beam Variant	Standard
Air Connection	1X125 mm
Product Overall Length	2.4 m
Manifold Type	C3
Air Discharge Throw	S
Nozzle Static Pressure	100 Pa
Fresh Air Supply Volume	20 l/s
Heating Function	H4
Underplate Perforation Type	51% DOT

Design Conditions

	Cooling	Heating
Flow Water Temperature	14.0 °C	50.0 °C
Return Water Temperature	17.0 °C	40.0 °C
Air Supply Temperature	14.0 °C	19.0 °C
Average Room Condition	24.0 °C	21.0 °C
"Air On" Thermal Gradient	0.7 °C	
Room Relative Humidity	45.0 %	

Dimensional Data

Width x Depth	592 x 230 mm
Overall Length	2392 mm
Water Volume	2.9 m³
Dry Weight	45.7 kg
CW Connection	Ø15 mm
LTHW Connection	Ø15 mm

Performance Data

	Cooling	Heating
Room - Mean Water dT	8.50 K	24.00 K
Air On Coil - Mean Water dT	9.20 K	22.00 K
Waterside Performance	972 W	930 W
Water Mass Flowrate	0.077 kg/s	0.022 kg/s
Waterside Pressure Drop	11.7 kPa	2.9 kPa
Airside Performance	240 W	-48 W
Total Sensible Performance	1212 W	882 W
Sound Effect LW	< 35 dB(A)	

Design Check (Warnings)

Air Discharge	OK
Supply Air	OK
Cooling Circuit	OK
Heating Circuit	OK
Turn Down Vol @ 40Pa	12.7 l/s
Calculated Dew Point	11.3 °C

Model Ref: ECHQCH24007D-125H15C3H4-20100S

Notes:

1) Performance calculations are based upon normal clean potable water, it is the system engineer's responsibility to allow for any reduction in cooling or heating performance due to additives that may reduce the water systems heat transfer coefficient.

2) Pressure drop calculations are based upon CIBSE guides using clean potable water and exclude any additional losses associated with entry / exit losses, pipe fouling or changes in water quality; it is the system engineer's responsibility to use good engineering practice.

Design Conditions	Cooling	Heating
Flow Water Temperature	14.0 °C	50.0 °C
Return Water Temperature	17.0 °C	40.0 °C
Air Supply Temperature	14.0 °C	19.0 °C
Average Room Condition	24.0 °C	21.0 °C
"Air On" Thermal Gradient	0.7 °C	
Room Relative Humidity	45.0 %	

Complete your project data in the "Design Conditions" section. Please note that the "Air On" Thermal Gradient should not be used in normal instances.

Performance Data	Cooling	Heating
Room - Mean Water dT	8.50 K	24.00 K
Air On Coil - Mean Water dT	9.20 K	22.00 K
Waterside Performance	972 W	930 W
Waterside Mass Flowrate	0.077 kg/s	0.022 kg/s
Waterside Pressure Drop	11.7 kPa	2.9 kPa
Airside Performance	240 W	-48 W
Total Sensible Performance	1212 W	882 W
Sound Effect LW	<35 dB(A)	

"Performance Data" will then automatically be calculated. Likewise "Dimensional Date" will be also automatically calculated.

Finally, the "Design Check" should read "OK" in green, or detail some warning in red.

Calculation programs for Eco HQ are available upon request.

Contact our technical department or complete an application request form from www.frenger.co.uk from the relevant link on our home page.

Project Specific Testing Facility

The 3 number state-of-the-art Climatic Testing Laboratories at Frenger's Derby based technical centre, have internal dimensions of 6.3 x 5.7 x 3.3m high and includes a thermal wall so that both core and perimeter zones can be modelled. The test facilities are fixed in overall size and construction therefore simulation of a buildings specific thermal mass cannot be completed, it should, however be noted that a specific project can be simulated more accurately by recessing the floor and reducing the height as necessary.

Project Specific Testing

Project specific mock-up testing is a valuable tool which allows the Client to fully assess the proposed system and determine the resulting indoor quality and comfort conditions; the physical modeling is achieved by installing a full scale representation of a building zone complete with internal & external heat gains (Lighting, Small Power, Occupancy & Solar Gains).

The installed mock-up enables the client to verify the following:

- Product performance under project specific conditions.
- Spatial air temperature distribution.
- Spatial air velocities.
- Experience thermal comfort.
- Project specific aesthetics.
- Experience lighting levels (where relevant).
- Investigate the specific design and allow the system to be enhanced.



The project-specific installation and test is normally conducted to verify:

- Product capacity under design conditions.
- Comfort levels -air temperature distribution.
-thermal stratification.
-draft risk.
-radiant temperature analysis.
- Smoke test video illustrating air movement.

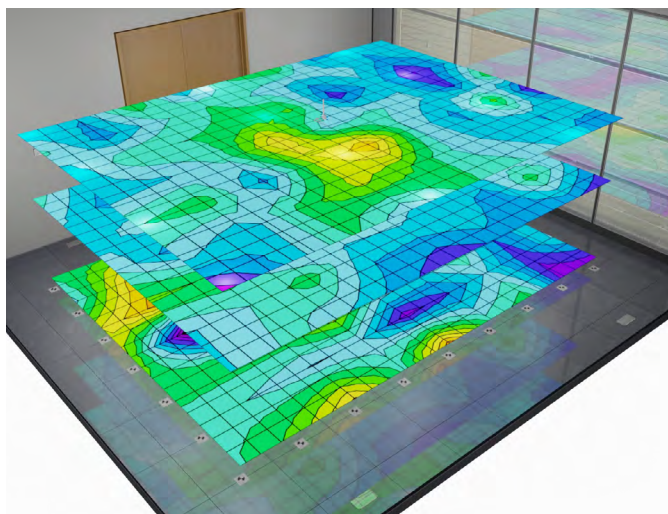

Photometric Testing Facility

The Photometric test laboratories at Frenger Systems are used to evaluate the performance of luminaires. To measure the performance, it is necessary to obtain values of light intensity distribution from the luminaire. These light intensity distribution are used to mathematically model the lighting distribution envelope of a particular luminaire. This distribution along with the luminaires efficacy allows for the generation of a digital distribution that is the basis of the usual industry standard electronic file format. In order to assess the efficacy of the luminaire it is a requirement to compare the performance of the luminaire against either a calibrated light source for absolute output or against the "bare" light source for a relative performance ratio.

The industry uses both methods. Generally absolute lumen outputs are used for solid state lighting sources and relative lighting output ratios (LOR) are used for the more traditional sources. Where the LOR method is chosen then published Lamp manufacturer's data is used to calculate actual lighting levels in a scheme.

The intensity distribution is obtained by the use of a Goniophotometer to measure the intensity of light emitted from the surface of the fitting at pre-determined angles. The light intensity is measured using either a photometer with a corrective spectral response filter to match a CIE standard observer curves or our spectrometer for LED sources.

Luminaire outputs are measured using our integrating sphere for a smaller luminaires or our large integrator room for large fittings and Multi Service Chilled Beams. For both methods we can use traceable calibrated radiant flux standards for absolute comparisons.

All tests use appropriate equipment to measure and control the characteristics of the luminaire and include air temperature measurements, luminaire supply voltage, luminaire current and power. Thermal characteristics of luminaire components can be recorded during the testing process as required.

A full test report is compiled and supplied in "locked" PDF format. Data is collected and correlated using applicable software and is presented electronically to suit, usually in Eulumdat, CIBSE TM14 or IESN standard file format.

Frenger conduct photometric tests in accordance with CIE 127:2007 and BS EN 13032-1 and sound engineering practice as applicable. During the course of these tests suitable temperature measurements of parts of LED's can be recorded. These recorded and plotted temperature distributions can be used to provide feedback and help optimise the light output of solid state light source based luminaires which are often found to be sensitive to junction temperatures.

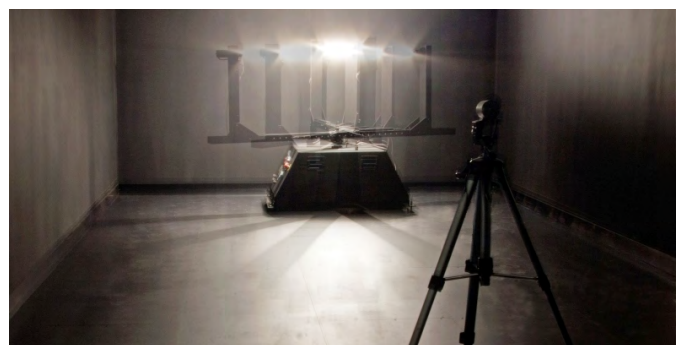
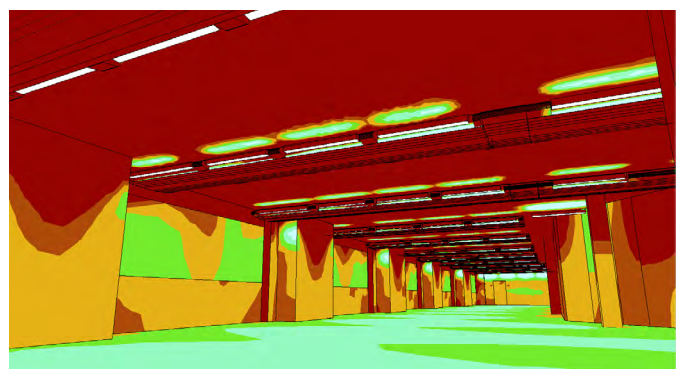

Acoustic Testing Facility

The Acoustic Test Room at Frenger is a hemi-anechoic chamber which utilises sound absorbing acoustic foam material in the shape of wedges to provide an echo free zone for acoustic measurement; the height of the acoustic foam wedges has the direct relationship with the maximum absorption frequency, hence Frenger has the wedges specifically designed to optimise the sound absorption at the peak frequency normally found with our active chilled beam products.

The use of acoustic absorbing material within the test room provides the simulation of a quiet open space without "reflections" which helps to ensure sound measurements from the sound source are accurate, in addition the acoustic material also helps reduce external noise entering the test room meaning that relatively low levels of sound can be accurately measured.

The acoustic facilities allow Frenger to provide express in-house sound evaluation so that all products, even project specific designs can be assessed and optimised.

To ensure accuracy Frenger only use Class 1 measurement equipment which allows sound level measurements to be taken at 11 different $\frac{1}{3}$ octave bands between 16 Hz to 16 kHz, with A, C and Z (un-weighted) simultaneous weightings.

In addition to the above, Frenger also send their new products for specialist third party Acoustic Testing. The results of which are very close and within measurement tolerances to that of Frenger's in-house measurement of sound.

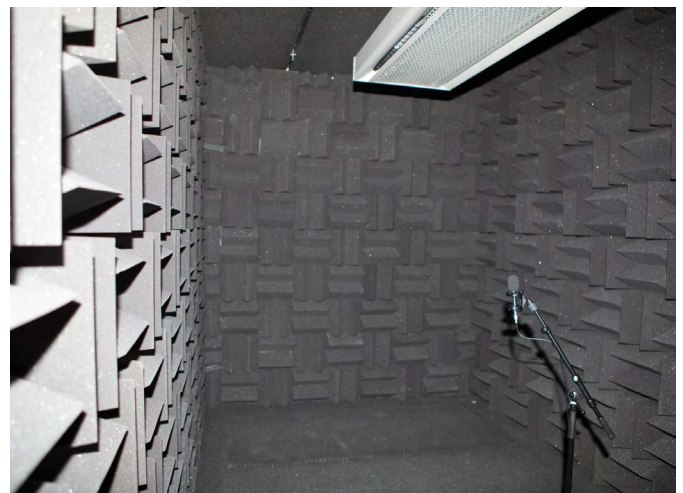
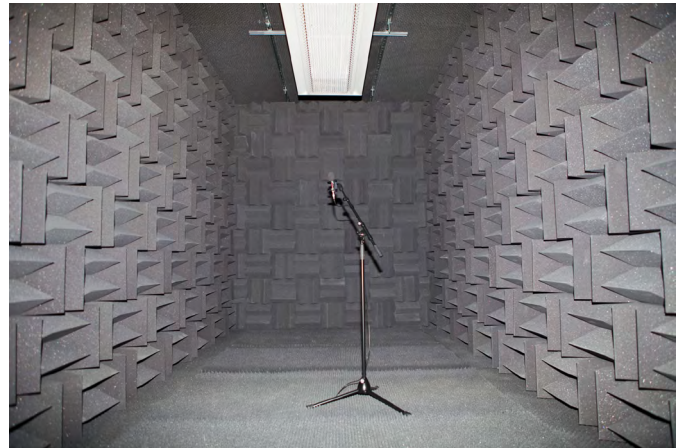

Unweighted Sound Pressure Level

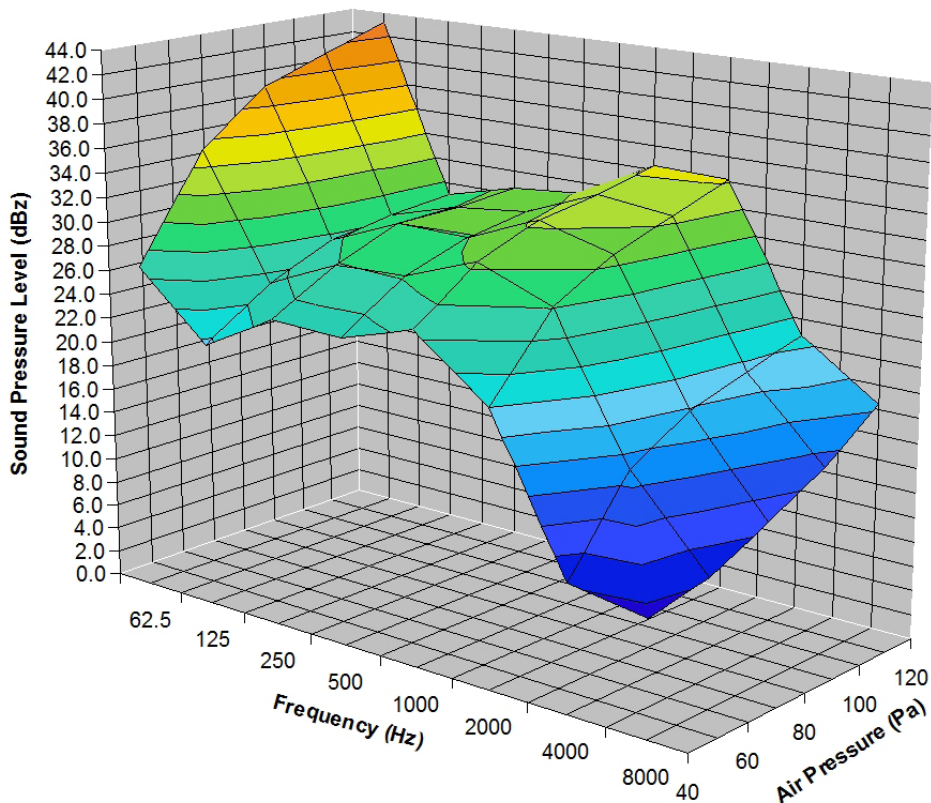



Frenger Systems participates in the ECC programme for Chilled Beams.
Check ongoing validity of certificate:
www.eurovent-certification.com or
www.certiflash.com 

FRENGER[®]

systems

UK Head Office

Frenger System Ltd
Riverside Road
Pride Park
Derby
DE24 8HY

tel: +44 0 1332 295 678
fax: +44 0 1332 381 054
sales@frenger.co.uk
www.frenger.co.uk

Australian Office

Frenger
Level 20
Tower 2
201 Sussex Street
Sydney
NSW 2000
Australia

tel: +61 2 9006 1147
fax: +61 2 9006 1010
sales@frenger.org.au
www.frenger.org.au

American Office

FTF Group Climate
1501 Broadway, Times Square
12th Floor
New York
NY 10036
United States of America

tel: +00 1 646 571 2151
fax: +00 1 646 571 2001
sales@ftfgroup.us
www.ftfgroup.us



Certificate No. FS 37431
Frenger is an FTF Group Company
Registered No. 646 6229 20

www.frenger.co.uk