



HEAT PUMP

for swimming pool water
heating & cooling

Installation and user manual



HP 1000 GREEN

HP 1400 GREEN

HP 1700 GREEN

COMPACT & SPLIT

Version: 01/2022

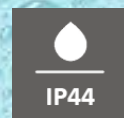



Thank you for purchasing Microwell swimming pool heat pump. Before you use this device, it is necessary to carefully read the entire Installation and user manual. It is not allowed to commence the heat pump installation or operation unless full content of this Installation and user manual is understood and acknowledged. Please keep the Installation and user manual available in the case of any future reference is required. Please provide this information also to each user of the device. Please mind local regulations in your country regarding installation and usage of this heat pump which are valid in addition to this User manual.

Content

1.	INTRODUCTION	3
1.1	Product description	3
1.2	Package checking.....	4
1.3	Waste disposal information	4
2.	SAFETY MEASURES	5
2.1	Electrical safety.....	5
2.2	Usage precautions	5
2.4	Transportation.....	8
3.	TECHNICAL SPECIFICATION	9
3.1	Technical data.....	9
3.2	Swimming pool water parameters	10
3.3	Heat pump dimensions	10
3.4	Exploded 3D view	11
3.5	Installation instructions.....	12
3.6	Multiple heat pump connection.....	13
3.7	Seaside installation.....	14
3.8	Electric wiring diagram.....	15
	SPLIT ADDITIONAL CONNECTION	15
4.	REGULATION.....	17
4.1	Description of wire controller	17
4.2	Operation Instruction.....	18
4.3	System parameter	19
4.4	System status.....	21
5.	TROUBLE SHOOTING FOR COMMON FAULTS	22
5.1	Repairing Guidance	22
5.2	Failure solution and code	22
6.	SPLIT – CONNECTION AND INSTALLATION	24
	Refrigerant circuit connection.....	25

Flaring work.....	26
Water unit dimensions.....	29
7. MAINTANANCE & WARRANTY	30
7.1 Maintenance.....	30
7.2 Warranty.....	30

1. INTRODUCTION

In your hands you hold probably the most advanced and the most efficient heat pump currently available on the market. This heat pump provides warm water in your pool at lowest possible cost. The heat pump is manufactured in tightest accordance with related strict standards and norms, in order to provide high quality operation and long-term reliability.

This Installation and user manual contains all the necessary information about the installation, operation and maintenance of the heat pump. Please read this Installation and user manual carefully before you start to use this product. The manufacturer is not responsible for any personal or property damage due to the improper installation, use or maintenance that is not in accordance with this User Manual.

This Installation and user manual is an inseparable part of this product; therefore it must be kept in good condition and must accompany the heat pump.

1.1 Product description

The heat pump is designed exclusively for swimming pool water heating or cooling and maintaining its temperature on the requested level. Other appropriate application is water temperature conditioning for fish tanks, wine ciders or horse cooling facilities. These applications should be discussed with local installer or distributor. Any other form of application is considered inappropriate.

The heat pump achieves the highest efficiency at 15÷35°C air temperature. At ambient air temperatures lower than -5°C the efficiency of the device decreases and at the temperatures higher than +40°C the heat pump can get overheated which may result in its malfunction, damage or failure. Do not use the product out of the designated operational air temperature range which is stated in section 3.1 *Technical data*.

The heat pump enables heat gain from the external air surrounding the swimming pool through the compression – expansion cycles of the heat-carrying liquid. The air is driven by a fan through the evaporator where it will deliver its heat to the heat-carrying liquid (the air is being cooled at the same time). The heat-carrying liquid is then delivered to the spirals of the exchanger by the compressor which pressurizes it and thus heats it up. In these spirals, the heat-carrying liquid delivers its heat to the swimming pool water. From the exchanger there is a cooled liquid flowing to the expansion valve or capillary where its pressure decreases and it gets cooled down rapidly at the same time. This cooled liquid flows to the evaporator again where it gets heated by the flowing air. The whole process runs fully automatically and is monitored by the pressure and temperature sensors. The same principle is applied when heat pump operates in cooling mode.

Using simple language, a heat pump is able to extract the heat/cold that is present in ambient environment and leveraged pass it into the pool water. When heating, higher the ambient air temperature is, more free energy can the heat pump extract and thus reach higher efficiency. At favorable conditions you pay around 15% of heat, i.e. 85% of heat is free. Please review below drawing of different ambient air conditions with subsequent efficiencies.

The heat pump efficiency grows by the increasing surrounding air temperature.

It takes some days to achieve the requested swimming pool water temperature. This time period depends on heat loss and heat gain balance of your pool.

Example factors of heat losses: poor pool construction, used materials, usage of cover, air – water temperature relationship, fresh water refilling, filtration, etc.

Example factors of heat gains: intensity of sun, winds, orientation of pool, air – water temperature relationship, etc.

In order to avoid heat loss when the swimming pool is not being used, it is highly advised to use pool's cover.

Ideal water temperature for external pools is considered at levels from 27° to 32°C. This may change based on particular demands of the user. When setting the desired air temperature higher than 32°C please review the material characteristics of your pool parts. High water temperature can damage these materials and contribute to creation of algae. Manufacturer, distributor and reseller do not bear responsibility resulting from inappropriate heat pump usage.

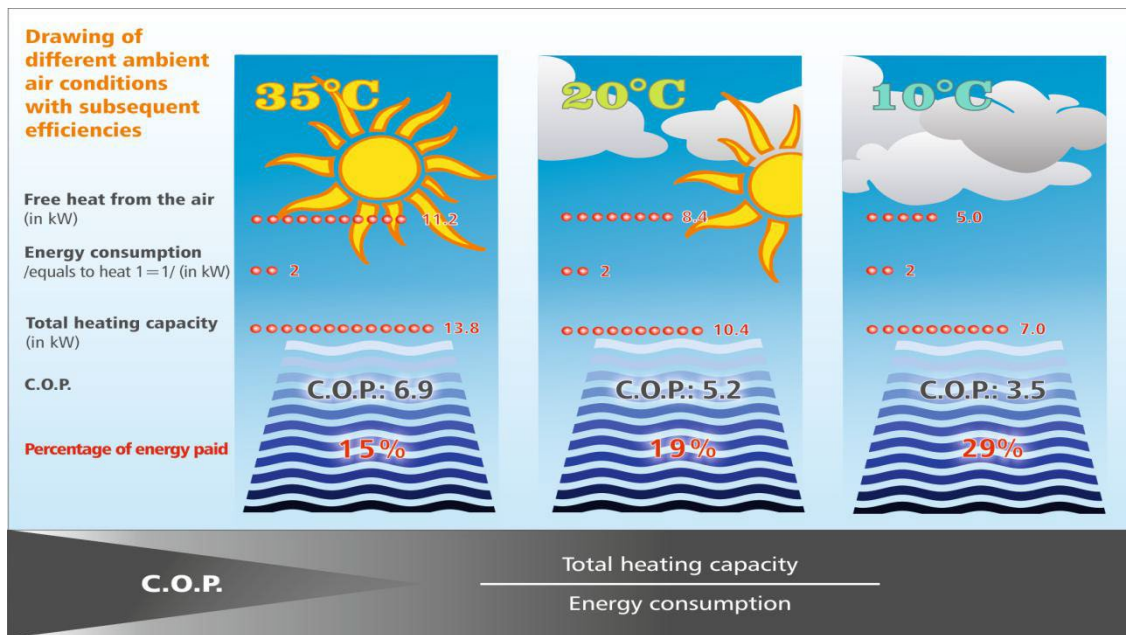

1.2 Package checking

The unit was delivered in carton box on a wooden palette. Do not accept the package if it shows signs of damage. If the package appears intact, please unpack the unit and check the content. It should include the following:

1. The heat pump – condensing unit, the heat exchanger.
2. This Installation and user manual
3. Four rubber silent blocks

1.3 Waste disposal information

When using this heat pump in the European countries, the following information must be followed:

DISPOSAL: Do not dispose this product as unsorted municipal waste. It is prohibited to dispose this heat pump in domestic / household waste. It is prohibited to dispose this appliance into forests or natural landscape. This could lead into local soil pollution. Collection of such waste must be treated individually.



DISPOSAL POSSIBILITIES:

1. The municipality has established a collection system where electronic waste can be disposed.
2. When buying a new product, the retailer or the manufacturer may take back the old appliance free of charge.
3. Old appliance may contain valuable resources which could be sold to scrap material dealers.



4. Disposal of packaging materials such as carton box or plastic / bubble foil can be recycled.

2. SAFETY MEASURES

It is necessary to follow instructions in this Installation and user manual and local regulations in your country that regulate the installation and usage of this device. Incorrect, improper or operations contradictory to this Installation and user manual may lead to an injury or property damage and will lead to loss of warranty. To prevent injury or property damage the following instructions must be followed:

2.1 Electrical safety



- *The device operates at dangerous electrical current.*
- *Only authorized person with particular electro-technical qualification can manipulate with unit.*
- *Danger of electrical shock.*
- *Do not exceed the required power supply.*
- *Do not turn the device on that shows signs of possible damage such as broken packaging, broken or otherwise damaged unit's chassis or cover, smoke, smell, etc.*
- *It is necessary to use appropriate Residual current circuit breaker (RCD) for connection of the heat pump to main power supply.*
- *Do not manipulate with the device with wet hands.*
- *Do not clean the device with water.*
- *Before cleaning the device, switch off the circuit breaker of the unit's power supply.*
- *Installation, service or repair must be performed by qualified technician.*
- *When the device is not intended to be used for a longer time, we recommend switching the circuit breaker of the unit's power supply off.*
- *Unit must be installed in vertical position to avoid condensate water to enter electrical part of the unit.*
- *It is forbidden to install the unit close to devices that may cause electrical or frequency disturbance such as welding machines, motors or rotors, WIFI/WLAN routers or repeaters.*
- *It is forbidden to alter electrical installation of the device. It is also forbidden to alter any other part or functionality of the device.*

2.2 Usage precautions

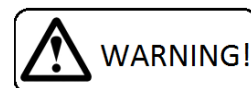

Do not cover or block the intake or exhaust opening / ventilator and evaporator covers. It is forbidden to block or cover the intake or exhaust openings with clothes, towels, buckets, canoes, trees, etc. Such action would lead to a decrease of needed airflow. That would result in heat pump inefficiency and underperformance, eventually to heat pump overeat with subsequent security turning off, and malfunction, failure or damage. Especially during bloom months it is highly advised to keep the evaporator fins clean.

- *Do not climb up on or sit on the unit.*
- *Do not place any objects on the top of the unit (e.g. boxes, flower vases, etc.).*
- *Do not spray any flammable substances into the equipment; this might lead to fire.*
- *Do not clean the equipment with aggressive cleaning agents; this might lead to damage or deformations.*
- *When cleaning plastic parts do not use any cleaning agents unsuitable for plastic (household cleaning agents, solvents, bleaching agents, benzene, diluents, rough cleaning powder, cresol, chemical agents). Instead, sweep the heat pump cover with a soft cloth or a sponge.*
- *Never throw or insert any objects into any hose or opening.*
- *The cover is made of metal. Do not manipulate with lighted cigarette, cigarette ashes, or any other kind of fire in vicinity to this part.*
- *Use this device exclusively for the intended purpose, as described in the attached instruction*

manual. Do not use parts which are not recommended.

- Never block the air opening of the product. Protect the air openings from clogging by particles.
- Do not drink or use the condensate water drained from the unit. Do not return the water back to the swimming pool. The water may be contaminated with bacteria.
- Children are not allowed to operate, touch or play with the unit.
- **Children are not allowed to manipulate with packaging, plastic / bubble foil. Risk of suffocation!**
- Prevent the children from injury or harm caused by any manipulation with the unit, its parts or its packaging. Small parts like screws may be swallowed and cause harm to health.
- Do not leave the children in the swimming pool / at the swimming pool unattended.
- The positioning of the heat pump must be in accordance with the STN 33 2000-7-702 standard, i.e. it must be placed at least 3,5 m from the swimming pool's external border.
- For heating/cooling the swimming pool by the heat pump, the filtration pump must run and the water must flow through the heat exchanger.
- Never turn on the heat pump if it is without water and if the filtration device is not operating.
- Protect the heat pump from freezing. Eliminate the water from the filtration and from the heat pump's water heat exchanger and prepare the product for the winter time.
- At low surrounding ambient temperature level (below 10°C) and high relative air humidity level (e.g. after rain, during the night, etc.), the evaporator may get iced up. Heat pump will automatically defreeze itself. Its operations or functionality is not harmed but the efficiency decreases.
- Manufacturer does not bear any responsibility concerning damages caused by inappropriate heat pump selection, installation or application.
- Do not pressurize the water heat exchanger higher than 0.25MPa (2.5bar). By pressure of 0.5MPa (5bar) the water heat exchanger gets irreversibly damaged. It is advised to install a security valve with pressure threshold at 0.25MPa (2.5Bar) before the heat exchanger.
- Do not apply or use water of higher temperature than 45°C in water heat exchanger. Water temperature above 60°C irreversibly damages the water heat exchanger.
- Manufacturer does not bear any responsibility concerning damages caused by inappropriate heat pump performance and/or model selection, installation or application. Heat pump is considered undersized in the case it works usually and in long-term more than 18 hours daily. General warranty void applies for damages on the device or other damages if the device works usually in long-term more than 18 hours daily.
- The heat pump must be correctly sized for its application.
- Refrigerant connection between the water and the condensing unit must comply with local refrigerant regulations. Typically, the refrigerant circuit must be sealed. Manufacturer does not bear any responsibility for damages caused by incorrect refrigerant works.



1) Warning



a. The WARNING sign denotes a hazard. It calls attention to a procedure, practice, or the like, which, if not correctly performed or adhered to, could result in personal injury or injury to a third party. These signs are rare, but are extremely important.

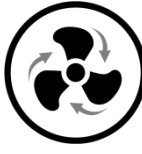

a. Keep the heat pump away from fire source.

	<p>b. It must be placed in well ventilated area, indoor or closed area is not allowed.</p>
	<p>c. Repair and disposal must be carried out by trained service personnel</p>
	<p>d. Vacuumize completely before welding. Welding can only be carried out by professional personnel in service center.</p>

2) Attention

- a. Please read the following instructions before installation, use and maintenance.
- b. Installation must be done by professional staff only in accordance with this manual.
- c. A leakage test must be performed after installation.
- d. If a repair is required, please contact the nearest after-sales service center. The repair process must be strictly in accordance with manual. All repair practice by non-professional is prohibited.
- e. Set proper temperature in order to get comfortable water temperature to avoid overheating or overcooling.
- f. Please don't stack substances, which will block air flow near inlet or outlet area, otherwise the efficiency of the heater will be reduced or even stopped.
- g. Don't use or stock combustible gas or liquid such as thinners, paint and fuel to avoid fire.
- h. In order to optimize the heating effect, please install heat preservation insulation on pipes between swimming pool and the heater, and please use a recommended cover on the swimming pool.
- i. Connecting pipes of the swimming pool and the heater should be $\leq 10\text{m}$.

3.) Safety

- a. Please keep the main power supply switch far away from the children.
- b. When a power cut happens during operating, and later the power is restored, the heater will start up.
- c. Please switch off the main power supply in lightening and storm weather to prevent from machine damage that caused by lightning;
- d. Any repairing should be conducted in the area with good ventilation. The ignition source is prohibited during the inspection.
- e. Safety inspection must be carried before the maintenance or repair for heat pumps with R32 gas in order to minimize the risk.
- f. If R32 gas leaks during the installation process, all operations must be stopped immediately and call the service center.

2.3 Handling precautions



- *Transport in lying position or turning the device over may harm the compressor resulting in unit's malfunction, failure or damage and will lead to loss of warranty.*
- *The device must be handled with care and special attention avoiding any mechanical damage.*
- *It is forbidden to apply any improper mechanical force onto the unit. This may cause mechanical damage to the device.*
- *It is forbidden to let the device fall freely onto the ground or any solid surface resulting in hard impact.*
- *Please notify your reseller or distributor if you suspect that the unit was delivered damaged. Unit may seem to work well at start but small damage can make the unit go out-of-order in short time. In such case the unit must be inspected and approved for further use by your reseller.*
- *Please notify your reseller or distributor if directly after installation you suspect that unit is not working in perfect order.*
- *In the case of device failure resulting from improper handling or mechanical damage (impact, hit, fall, etc.), the manufacturer reserves the right to evaluate the continuity of warranty.*

2.4 Transportation

a. Always keep upright

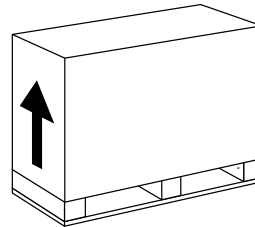

b. Do not lift the unit by water union
(If so, the titanium heat exchanger
inside the heat pump may be damaged)

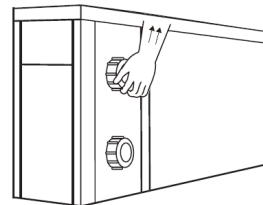

3. TECHNICAL SPECIFICATION

3.1 Technical data

Model	HP1000 GREEN	HP1400 GREEN	HP1700 GREEN
AMBIENT TEMPERATURE: (DB/WB) 27°C/24.3°C; WATER INLET/OUTLET TEMPERATURE: 26°C/28°C.			
Heating capacity (kW)	9.2	12.3	16.2
Power input (kW)	1.52	2.05	2.7
COP	6.05	6.0	6.01
AMBIENT TEMPERATURE: (DB/WB) 15°C/12°C; WATER INLET TEMPERATURE: 26°C.			
Heating capacity (kW)	6.4	8.57	11.3
Power input (kW)	1.4	1.8	2.4
COP	4.7	4.7	4.72
Power supply	220-240V / 50Hz		
Max power input (kW)	2.2	2.65	3.6
Max current(A)	10.3	12.4	16.4
Heating water temperature range	15°C~40°C		
Running ambient temperature range	-5°C~40°C without winter accessories -15°C~40°C with winter accessories		
Refrigerant	R32		
Air side heat exchanger	Hydrophobic Goldfin exchanger		
Water side heat exchanger	Titanium tube heat exchanger		
Water flow(m³/h)	4	5.3	7.1
Net dimension LxWxH (mm)	910x360x620	1000x385x665	
Water pipe connection (mm)	50		
Net weight (kg)	39	49	56
Noise level dB(A)	46	52	54

* The manufacturer reserves the right to change the parameters without notice.

The refrigerant circuit is filled with R32.

Refrigerant R32 also called HFC-32 or difluoromethane. R32 is a molecule used as refrigerant that has zero ozone depletion potential (ODP).

R32 with the global warming potential (GWP) index 675 times that of carbon dioxide, based on a 100-year time frame, and it is classified as A2L - slightly flammable by ASHRAE.

1. Noise at 1 m, at 4 m and at 10 m in accordance with Directives EN ISO 3741 and EN ISO 354
2. Calculated according to an in-ground private swimming pool covered with bubble plastic cover

3.2 Swimming pool water parameters

The heat pump is designed for heating the swimming pool water. Although the water heat exchanger is made from the most durable titanium, in order to ensure long term reliability of the heat pump the pool water must be in accordance with the related sanitary requirements.

The limit values for the heat pump operation are the following:

- pH value ranging from 6.8 to 7.9,
- total chlorine amount not exceeding 3 mg/l,
- salt content 6% wt/wt.

Should you have different values of pH, chlorine or salt please try to apply appropriate agents or contact your swimming pool builder to resolve the situation. Above mentioned values are recommended for pools in general.

It is also advised to keep the water hardness on the lower limit of the optimal range, i.e. closely above 8 °N.

3.3 Heat pump dimensions

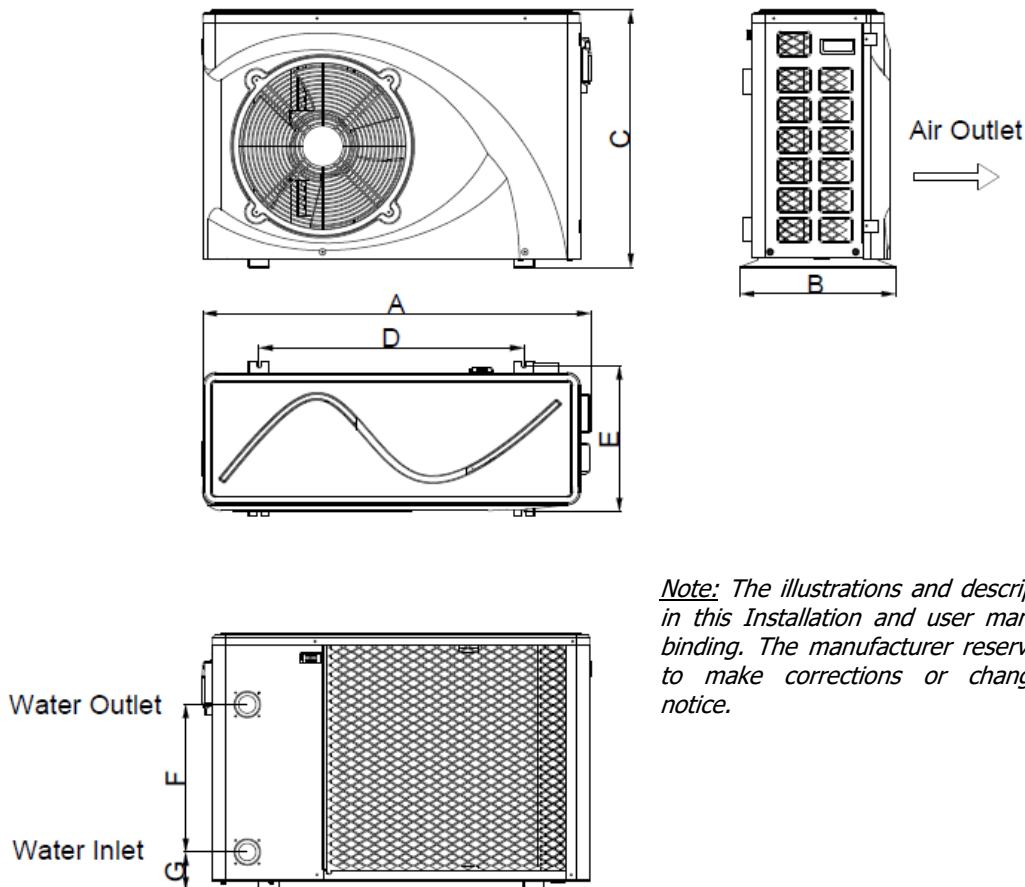

Note: The illustrations and descriptions found in this Installation and user manual are not binding. The manufacturer reserves the right to make corrections or changes without notice.

Model	A	B	C	D	E	F	G
HP1000 GREEN	910	360	620	591	330	310	98
HP1400 GREEN	1000	385	665	681	373	380	98
HP1700 GREEN							

3.4 Exploded 3D view

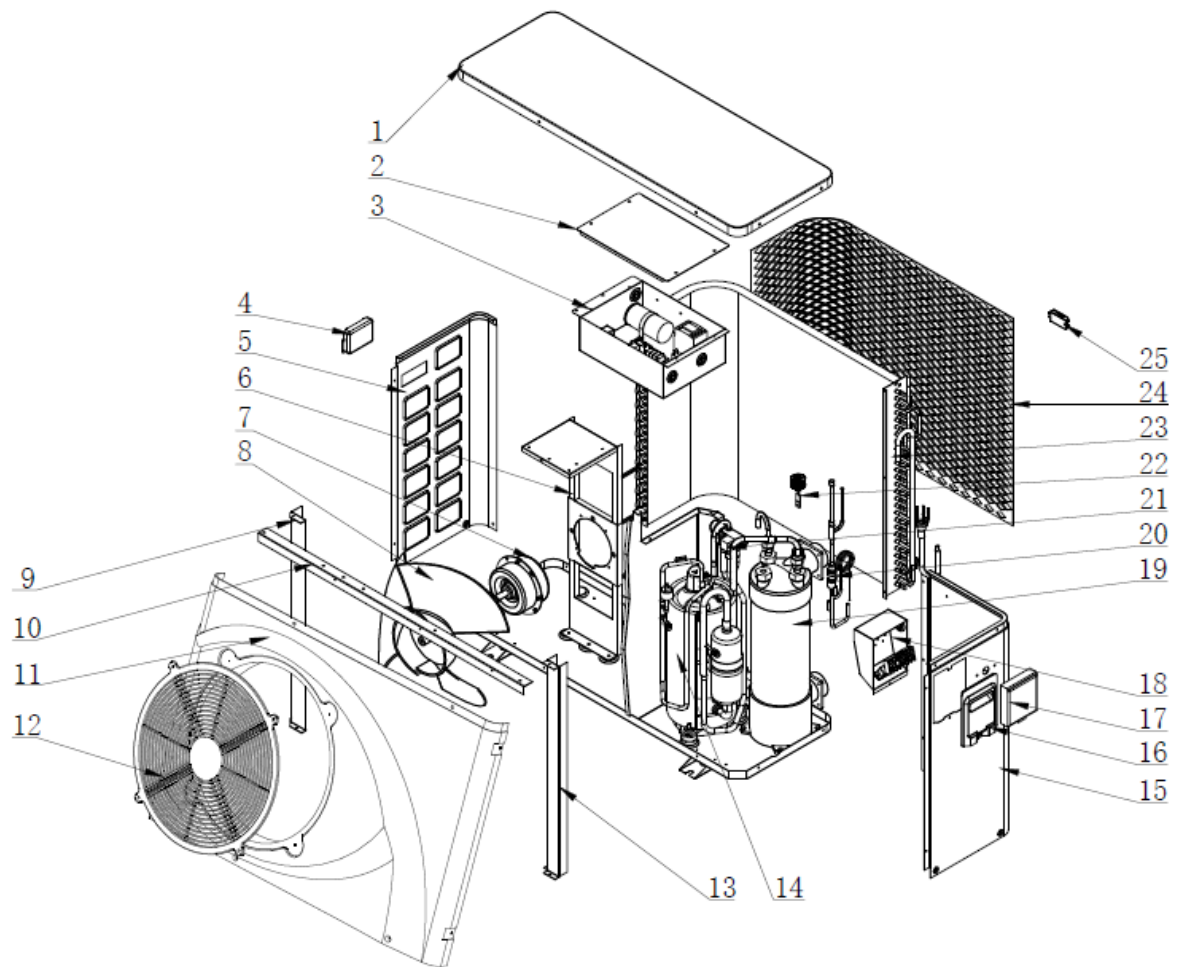

1	Top cover	10	Fixed plate 2	19	Titanium heat exchanger
2	Electrical box cover	11	Front plate	20	Filter component
3	Electrical component	12	Fan motor cover	21	Four way valve
4	Left handle	13	Fixed plate 3	22	Water flow switch
5	Left chassisplate	14	Compressor	23	High efficiency finned heat exchanger
6	Motor support	15	Right plate	24	Back net
7	Fan motor	16	Right handle	25	Ambient air sensor position
8	Fan	17	External WiFi		
9	Fixed plate 1	18	Wiring box		

3.5 Installation instructions

WARNING: Installation must be carried out by a qualified engineer.

This section is provided for information purpose only and must be checked and adapted if necessary according to actual installation condition.

a. Pre-Requirements

Needed equipment for installation of heat pump:

- Suitable power supply cable for unit's power.
- A by-pass kit and an assembly of PVC tube, stripper, PVC adhesive and sandpaper.
- A set of wall plug and expansion screw.
- We recommend using flexible PVC pipe in order to reduce transmission of vibration.
- Suitable fastening studs may be used to raise unit.

b. Location

Please comply with the following rules about heat pump location choosing.

1. The unit's location must be convenient for operation and maintenance in the future.
2. It must be installed and fixed on flat concrete floor. The floor is stable to support the weight of the unit.
3. A water drainage device must be provided close to the unit in order to protect the area where it is installed.
4. If necessary, mounting pads could be used to support the weight of unit.
5. Confirm the unit is under well-ventilated condition; air outlet port is not facing to the windows of nearby buildings and the outlet air cannot be returned. In addition, provide enough space around the unit for repair and maintenance.
6. The unit must not be installed in an area exposed to oil, flammable gases, corrosive products, sulphurous compounds or close to high frequency equipment.
7. To prevent mud splashes, do not install the unit near road or track.
8. To avoid noise to neighbors, please make sure the unit is installed in less noise sensitivity area or good sound isolation area.
9. Keep the unit as far as possible away from children.
10. Installation space

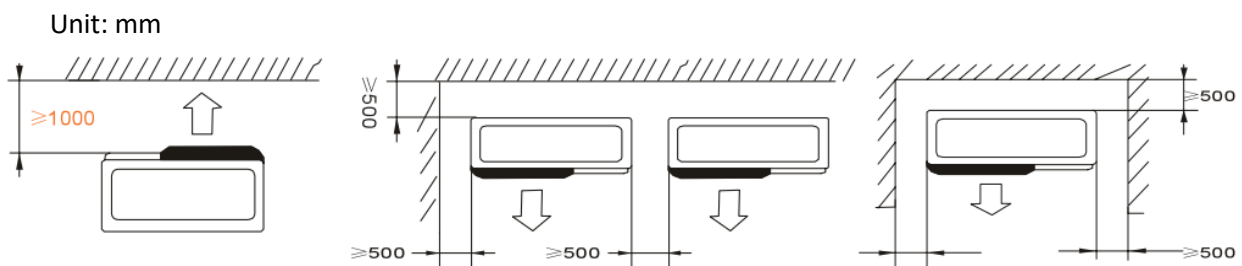

Anything could not be placed within at least 1m in front of heat pump.

Leave at least 500mm of empty space around the sides and rear of heat pump.

Do not put any stuff on or in front of heat pump!

c. Installation layout

Always install the heat pump after filtration and before chemical treatment (e.g. chlorinator).

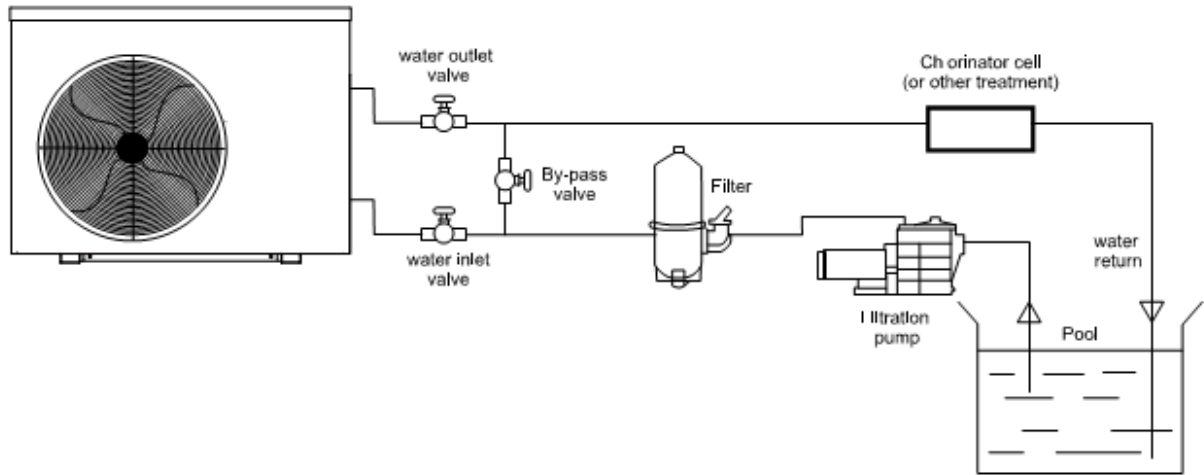

3.6 Multiple heat pump connection

Sometimes it is necessary to install multiple heat pumps into a single swimming pool in order to achieve requested water temperature. Such installation is particularly advised on public venues where continuity of operation / service is paramount.

Installation of the multiple heat pumps follows the same procedure as single heat pump described above. It is only necessary to install the heat pumps in **parallel connection**. Serial connection would significantly decrease the heating/cooling capacity and efficiency of heat pumps second in line. It is advised to insert individual valves into connecting water piping for each single heat pump. This will simplify the particular heat pump by-pass (disconnection) in the case of reinstallation, testing or service. Please refer to below illustration.

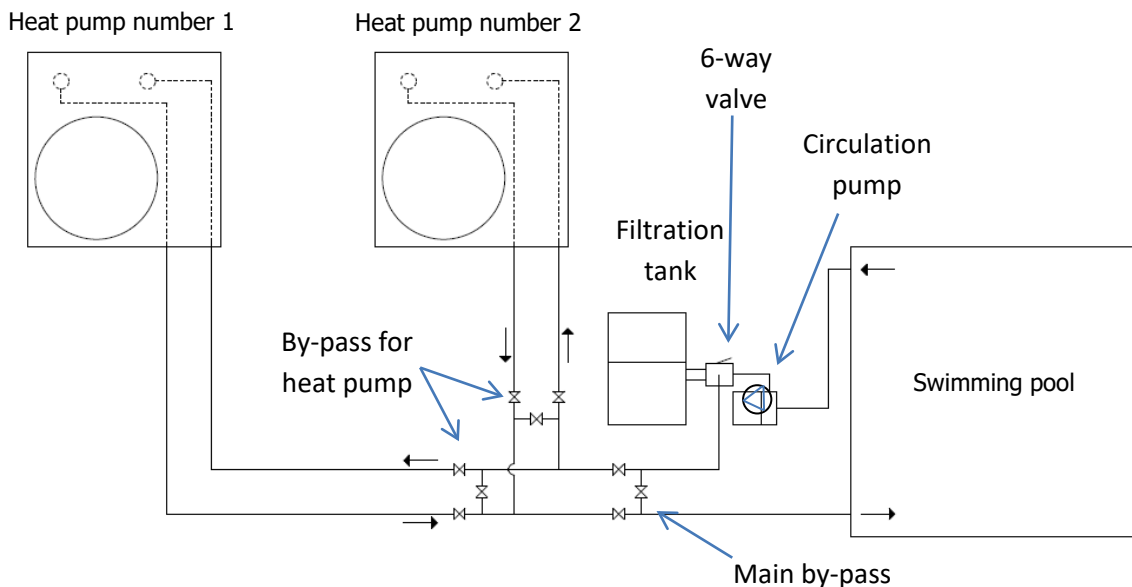

By multiple heat pump connection it is possible have all the heat pumps **always on** and running when heating / cooling is required or to have the heat pumps **gradually turning on** and off so at certain conditions (e.g. when requested water temperature is few degrees off the current water temperature) not all the heat pumps would run. Gradual turning on and off is achieved by setting the different requested water temperatures on multiple heat pumps. For example:

Heat pump 1 30°C

Heat pump 2 28°C

3.7 Seaside installation

Some condensing units are installed in locations close to sea or ocean. Please note that condensing unit should not be installed in areas where corrosive gases, such as acid or alkaline gas, are present or produced. Do not place the condensing unit where it can be exposed to direct sea wind (salty wind). This would lead into corrosion. This could result in heat pump malfunction, failure or damage. In any case you should avoid a direct exposure of sea wind. This can be done with the help of a windbreak (e.g. small wall). The dimensions of the windbreak should be 1.5 bigger than condensing unit in both height and width. Please leave 70cm of free space between the windbreak and the condensing unit.

Please check your unit on regular basis and it is advised to clean the unit more than once a year with water to remove salt particles.

Should you not be able to meet above, please speak to your distributor or reseller.

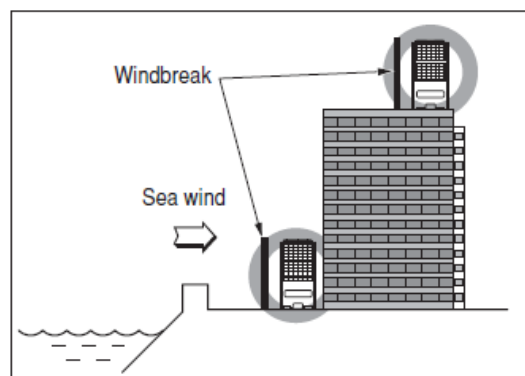
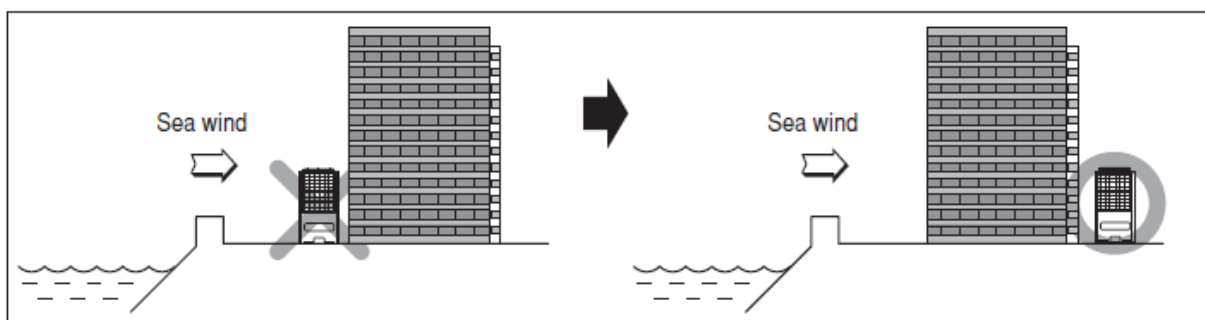

3.8 Electric wiring diagram

WARNING: Power supply of heat pump must be disconnected before any operation.

Please comply with the following instruction to connect heat pump:

- Connect to appropriate power supply; the voltage should comply with the rated voltage of the products.
- Earth the machine well.
- Wiring must be handled by a professional technician according to the circuit diagram.
- Set leakage protector according to the local code for wiring (leakage operating current $\leq 30\text{mA}$).
- The layout of power cable and signal cable should be orderly and not affecting each other.

Electric wiring Diagram - For power supply: 230V 50Hz

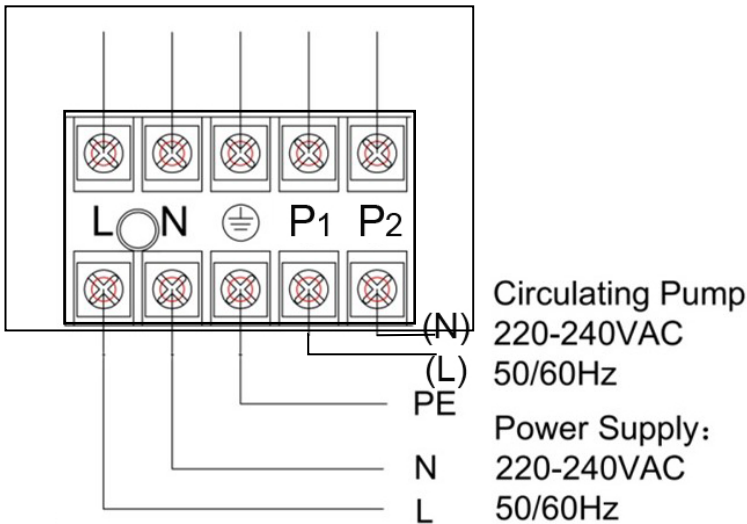

COMPACT version



SPLIT version

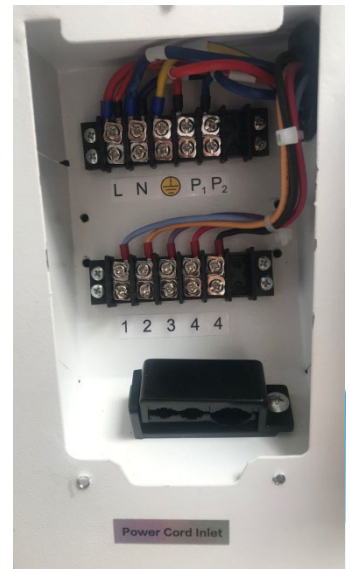

SPLIT ADDITIONAL CONNECTION

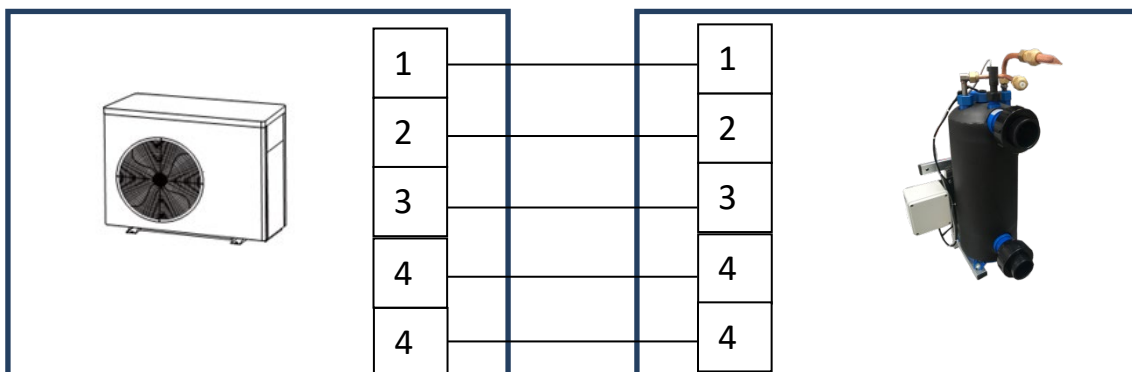

By a split make of the unit, the water unit is connected with condensing unit with a 5 wire cable 0.5mm² CYSY used as signal cable for sensors present in the water unit.

Manufacturer suggests connection of circulation pump through switching relay. Please refer to below drawing for more information.

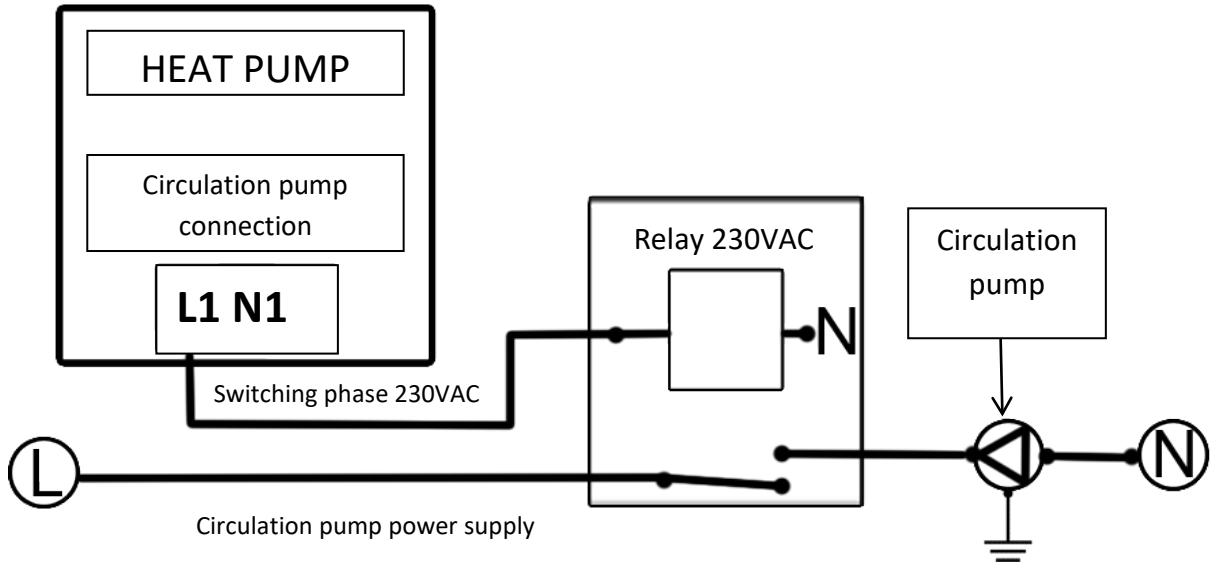

Direct connection of the circulation pump as shown below is not advised.

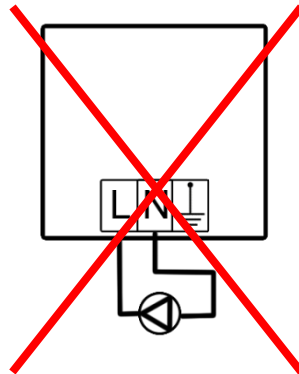

Reference for protecting devices and cable specification

Model	Power Supply Wires		
	Electricity Supply	Cable Diameter	Specification
HP1000 GREEN	220-240V/50Hz	3×2.5mm ²	AWG 14
HP1400 GREEN		3×2.5mm ²	AWG 14
HP1700 GREEN		3×4.0mm ²	AWG 12

※ Above data is subject to modification without notice.





Note: The above data is adapted to power cord ≤ 10m. If power cord is > 10m, wire diameter must be increased. The signal cable can be extended to 50m maximum.





4. REGULATION

4.1 Description of wire controller

Control panel appearance



Basic icon	Designation	Function
	ON/OFF button	Press this button briefly in other interface to return to the main interface. Press this button in the main interface to turn on/off unit.
	Mode button	When the unit is on, press this button briefly to switch modes: heating mode, refrigeration mode. Long press this button 5s together with button up arrow  to enter the system parameter query. The system parameter can be inquired by using the UP or DOWN button. → SYSTEM STATUS In the parameter query state, press this button briefly to enter parameter settings. The system parameter can be set by using the UP or DOWN button.
	UP button	When the unit is on, press this button in the main interface to turn up the temperature. Press this button to adjust the rise when adjusting parameters.
	DOWN button	When the unit is on, press this button in the main interface to turn down the temperature. Press this button to adjust the drop when

		adjusting parameters.
	TIMER ON button	Set the timer
	HEATING mode	When in heating mode, it lights up.
	COOLING mode	When in cooling mode, it lights up.
	DEFROSTING mode	When in defrosting mode, it flashes.

- When the unit is on, it displays error code if there is an error; it displays water inlet temperature if there are no errors.
- When the unit is off, it displays error code if there is an error; it displays current time if there are no errors.

4.2 Operation Instruction



TIMER ON button

Press this button briefly in the main interface to enter the Timer ON time setting. The four digital fields flash at the same time, and the timer on indicator flashes. Press this button again to enter the hour setting of Timer ON setting. When the hour part of digital tube flashes, press the UP or DOWN button for numerical adjustment; Press this button again to enter the minute setting. When the minute part of digital tube flashes, press the UP or DOWN button for numerical adjustment. Press this button or the ON/OFF button to exit after completion.



TIMER OFF button

Press this button briefly in the main interface to enter the Timer OFF time setting. The four digital fields flash at the same time, and the timer off indicator flashes. Press this button again to enter the hour setting of Timer OFF setting. When the hour part of digital tube flashes, press the UP or DOWN button for numerical adjustment; Press this button again to enter the minute setting. When the minute part of digital tube flashes, press the UP or DOWN button for numerical adjustment. Press this button or the ON/OFF button to exit after completion.



CLOCK button

Press this button on the main interface to enter the clock setting. The four digital fields flash at the same time. The clock indicator flashes. Press this button again to enter the hour setting of current time. The digital tube flashes in minutes. Press the UP or DOWN button for numerical adjustment. Press this button or the ON/OFF button to exit after completion.

When setting the timing time, press this button to cancel the timing and return to the main interface. The corresponding timing indicator will be off.

4.3 System parameter





A: Check the current temperature

B: Check system parameters.

System parameter:

Code	Display code	Meaning	Range	Default	Remarks
0	0	Memory Function	0 (N/A) /1 (A)	1	Adjustable
1	1	Daily Cycle Mark	0 (N/A) /1 (A)	1	Adjustable
2	2	Return Difference X	2-10°C (35.6°F-50°F)	3	Adjustable
3	3	Return Difference Y	0-3°C (32°F -37.4°F)	0	Adjustable
4	4	Defrosting Cycle	30-90Min	40Min	Adjustable
5	5	Temp. to Enter Defrosting	-30°C-0°C (-22°F -32°F)	-1°C (30.2°F)	Adjustable
6	6	Temp. to Exit Defrosting	2-30°C (35.6°F -86°F)	15°C (59°F)	Adjustable
7	7	Time to Exit Defrosting	1-12Min	8Min	Adjustable
8	8	Exhaust Protection	90-120°C (194°F -248°F)	110°C (230°F)	Adjustable
9	9	Upper Setting Temp.	40-65°C (104°F -149°F)	40°C (104°F)	Adjustable

A	A	Water Pump Mode	0 (Special) /1 (Common)	1	Adjustable
B	b	Water Pump Stop Time When Reaching the Target Temp	3-20MIN	15	Adjustable
C	c	Secondary Frost Protection	0 (Heat Pump) /1 (Electric Heater)	1	Invalid
D	d	Type Selection	0(Single Cooling) 1 (Heating&Cooling) 2 (Single Heating)	1	Adjustable
E	E	High Pressure Switch	0: Alarm when closing 1: Alarm when opening 2: Disable	1	Adjustable
F	F	Low Pressure Switch	0: Alarm when closing 1: Alarm when opening 2: Disable	2	Adjustable
G	G	Water Flow Switch	0: Close when water flow is abnormal 1: Open when water flow is abnormal 2: Disable	1	Adjustable
H	H	Emergency Switch	1: Available 2: Disable	1	Adjustable
I	I	Electric heater overheat protection	1: Alarm when opening 2: Disable	2	Adjustable
J	J	EEV Action Cycle Setting	20-90s	30s	Adjustable
K	K	Target superheating Setting	-8°C~-15°C(-14°F~27°F)	2°C(4°F)	Adjustable
L	L	Allowable exhaust temp. of EEV Action	60°C~115°C(140°F~239°F)	100°C(212°F)	Adjustable

M		EEV Opening of Defrosting	2~45	40	Actual Value=10* Displayed Value
N		EEV Min. Opening	6~15	6	Actual Value=10* Displayed Value
O		EEV Action Mode	0(Manual)/1(Automatic)	1	Adjustable
P		EEV Manual Opening	2~45	30	Actual Value=10* Displayed Value

4.4 System status

Code	Meaning	Range	Remarks
1	Water Inlet Temp.	-9~99°C (16°F-210°F)	Measured
2	Water Outlet Temp.	-9~99°C (16°F-210°F)	Measured
3	Coil Temp. (Evaporator GoldFin)	-9~99°C (16°F-210°F)	Measured
4	Exhaust Temp. (Compressor)	0~125°C(0-257°F)	Measured
5	Ambient Temp. (Air)	-9~99°C (16°F-210°F)	Measured
6	Suction Temp. (Gas return)	-9~99°C (16°F-210°F)	Measured
7	Cooling Coil Temp.	-9~99°C (16°F-210°F)	Measured
8	EEV Steps	0~48	Actual Value=10* Displayed Value

5. TROUBLE SHOOTING FOR COMMON FAULTS

5.1 Repairing Guidance



WARNING:

- a. If repair or scrap is required, please contact authorized service center nearby.
- b. Requirements for Service Personnel
- c. Any person who is involved with working on or breaking into a refrigerant circuit should hold a current valid certificate from an industry-accredited assessment authority, which authorizes their competence to handle refrigerants safely in accordance with an industry, recognized assessment specification.
- d. Do not attempt to work on the equipment by yourself. Improper operation may cause danger.
- e. Strictly comply with the manufacturer's requirements when charging R32 gas and equipment maintenance. This chapter focuses on special maintenance requirements for swimming pool heat pump with R32 gas. Please refer to the technical service manual for detailed maintenance operation.
- f. Vacuumize completely before welding. Welding can only be carried out by Professional personnel in service center.

5.2 Failure solution and code

Protection/Error Code	Description	Trouble shooting
P3	Water Inlet Temp. Sensor Failure	Check the connection, change the sensor if necessary.
P4	Water Outlet Temp. Sensor Failure	Check the connection, change the sensor if necessary.
P1	Coil Temp. Sensor Failure	Check the connection, change the sensor if necessary.
P7	Ambient Temp. Sensor Failure	Check the connection, change the sensor if necessary.
P2	Exhaust Temp. Sensor Failure	Check the connection, change the sensor if necessary.
E4	System High Pressure Failure	1. Detect the inlet/outlet water temperature. 2.Clean the water exchanger or water filter.

		3. Replace the high pressure switch.
PL	Water Flow Failure	Water flow too low or flow switch failure or cable connection failure. Check water flow /switch, change the switch if necessary.
P6	Excessive Temperature Difference of Water Inlet and Water Outlet	Check whether the water flow meets the requirement of nameplate.
E3	High Exhaust Temperature Protection	1. Check whether the refrigerant of the system is leaked. If the refrigerant leaks, repair the leak point and vacuum it again, then charge the refrigerant according to the type and weight of the refrigerant on the nameplate. 2. Replace exhaust temperature sensor. 3. Replace PCB control board.
P8	Excessive Low Temp of Water Outlet When Cooling	No need to deal with, it's the protection function
PC	Winter Level 1 Frost Protection	No need to deal with, it's the protection function
PC	Winter Level 2 Frost Protection	No need to deal with, it's the protection function
E8	Communication Failure	(Available for remote controller ONLY) 1. Check if the communication connection wire between display and PCB is well . 2. Change or amend the wire if necessary . Check the PCB or display. If damaged, Change the corresponding part.

Note: If the following conditions happen, please stop the machine immediately, and cut off the power supply immediately, then contact your dealer:

1. Inaccurate switch action.
2. The fuse is frequently broken or leakage circuit breaker jumped.

6. SPLIT - CONNECTION AND INSTALLATION

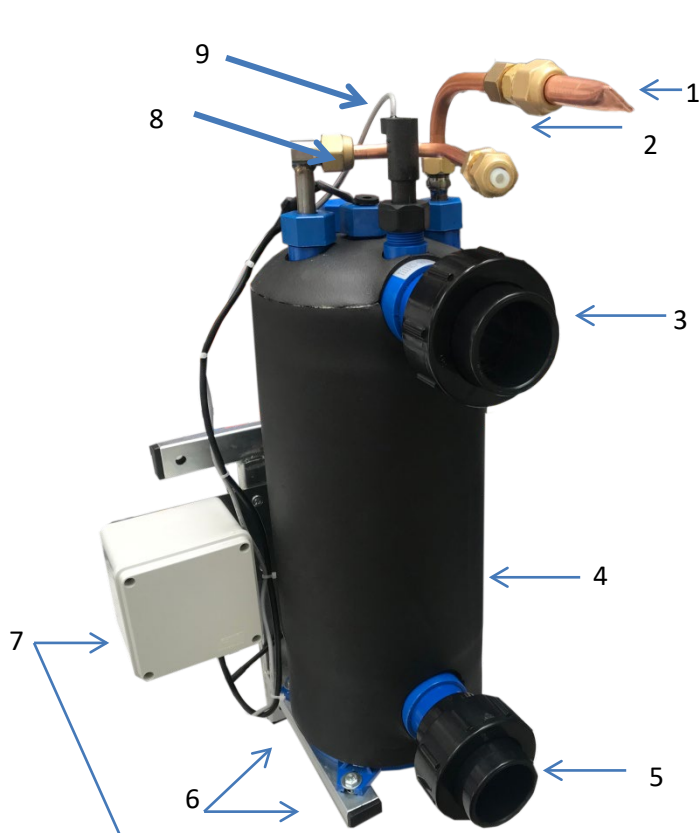

1. Gas R32
2. Gas R32
3. Water OUT
4. Heat exchanger body
5. Water IN
6. Screws fixing the exchanger on console 4x
7. Electro connection compartment
8. Water out sensor
9. Flow switch
10. Water in sensor
11. Fixation holes for screws to fix the console on a wall 4x
12. Main electrical connection of the condensing unit
13. Condensing /compressor / unit
14. Gas R32
15. Gas R32
16. Interconnecting cable /on demand/

The real product may differ from pictures.

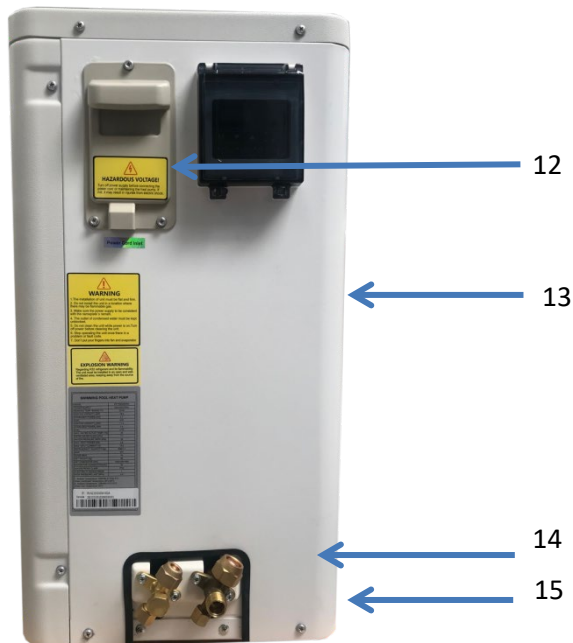
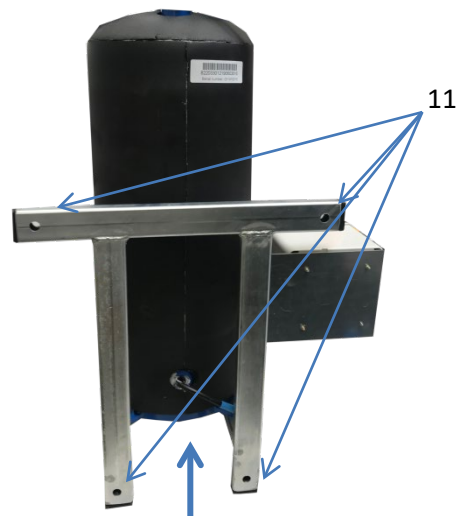

Refrigerant circuit connection

Split heat pump requires refrigerant circuit connection in order to operate normally. This is normally done during installation of the pump as the pump comes with separate (not connected) condensing and water units refrigerant-wise originally from the factory. Refrigerant circuit must be sealed.



IMPORTANT: Please note that refrigerant connection can be performed by an authorized person only. The person must have a valid refrigeration licence.

Condensing unit is pre-charged with refrigerant R32 from the factory. HP1000 550g, HP1400 750g and HP1700 1100g R32. This is sufficient for 0.5~1 meter long copper pipe connection. Above 0.5~1m, 25~40g/1m must be added to the system. PLEASE NOTE THAT THE ACTUAL REFRIGERANT CHARGE FOR YOUR UNIT MAY DIFFER, THUS PLEASE ALWAYS REFER TO NAME PLATE AND INFORMATION ATTACHED TO YOUR PARTICULAR UNIT.

Piping length and elevation

Heat pump model	Pipe size				Factory pre-charged connection distance	Factory pre-charged refrigerant	Additional refrigerant for 1m above 5m	Max. vertical distance (B)	Max. distance (A)
	Gas (diameter)		Liquid (diameter)						
	inch	mm	inch	mm					
HP1000	3/8	9.53	1/2	12.7	0.5m	550g	25g/m	15m	25m
HP1400	3/8	9.53	5/8	15.88	0.5-1m	750g	30g/m	15m	25m
HP1700	3/8	9.53	5/8	15.88	0.5-1m	1100g	40g/m	15m	25m

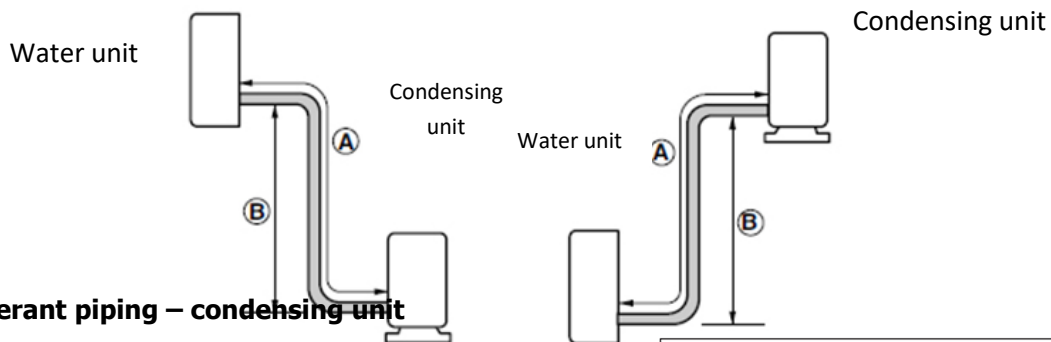

Refrigerant piping – condensing unit

1. Align the center of the pipings and sufficiently tighten the flare nut by hand. Please do so for both gas and liquid pipes.

Gas pipe has bigger diameter.

Liquid pipe has smaller diameter.

2. Tighten the flare nuts with torque wrench until the wrench clicks. Please make sure that the direction for tightening follows the arrow on the wrench.

Please review below table for torque force.



Please use refrigerant copper pipes with insulation only.

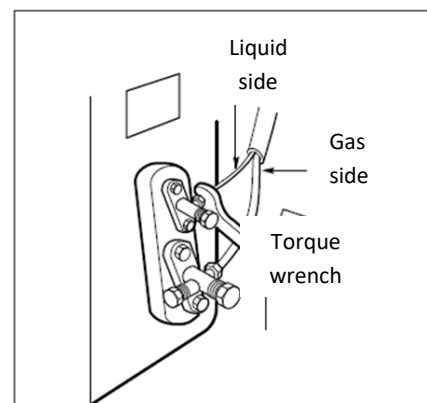
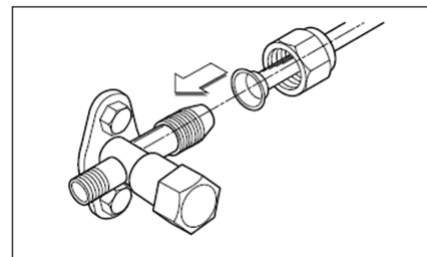

Outside diameter		Torque kgf m
inch	mm	
¼	6.35	1.8-2.5
3/8	9.52	3.4-4.2
½	12.7	5.5-6.6
5/8	15.88	6.3-8.2

3. Forming and insulation the piping.

The pipes must be insulation and secured with vinyl tapes. This is done in order to prevent condensation on the piping.

It is highly advised to place the piping into a plastic protector when installed in the ground (soil).

On places where piping goes through a wall or similar it is advised to use gum type sealer or construction foam to seal the openings.

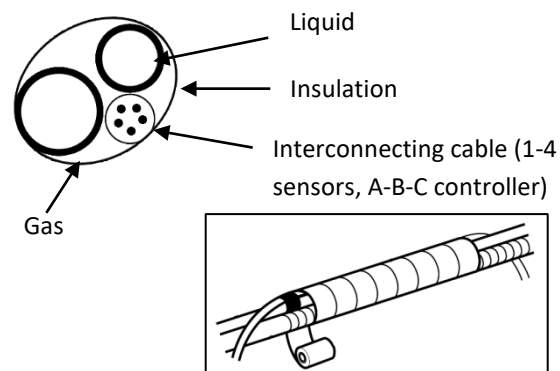

3.1. Condensing unit below water unit

Tape the piping and interconnecting cable from down upwards. Fix the tapped piping with cable binder or equivalent onto the exterior wall. It is important to make a trap to prevent water from entering into the electro installation of the condensing unit.

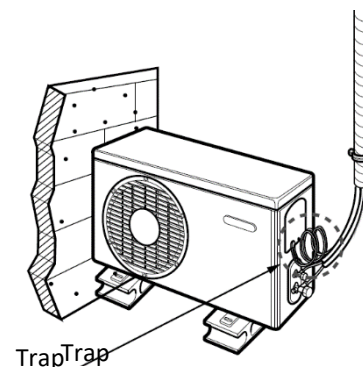

3.2 Condensing unit above water unit

Tape the piping and interconnecting cable from down upwards. Fix the tapped piping with cable binder or equivalent onto the exterior wall. It is important to make a trap to prevent water from entering into the electro installation of the condensing unit. On refrigerant side it is important to form a syphon.

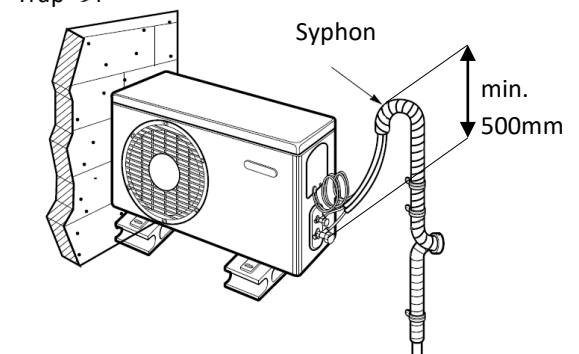

Flaring work

It is important to perform the flaring work correctly. This will have positive effect towards long-term reliability and functionality of the heat pump. Defective or incorrect flaring work is the most common cause for gas leakage. Gas leakage results in continuous decrease of heat pump efficiency and eventually leads into security turning off, malfunction, failure or damage.



Warranty does not cover any product, property or personal damages or losses that are a result of incorrect flaring work, gas leakage, incorrect welding work or improper material used.



When cutting the pipes and cables, please mind the following:

1. Measure the distance between the water and the condensing unit.
2. Cut the pipes a little longer than measured distance.

3. Cut the cable 1.5m longer than the pipe length.

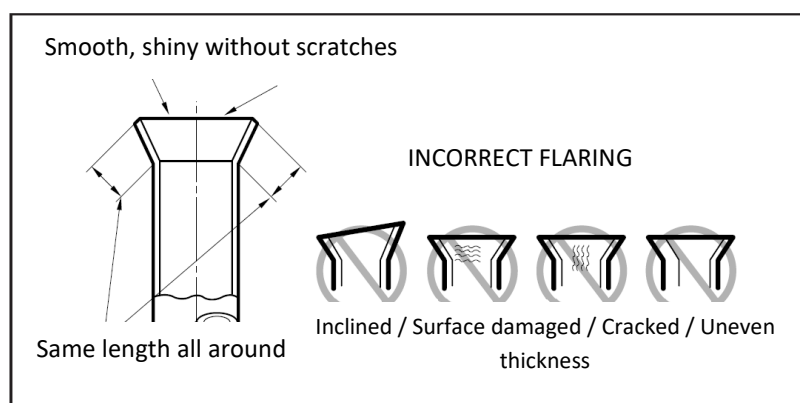
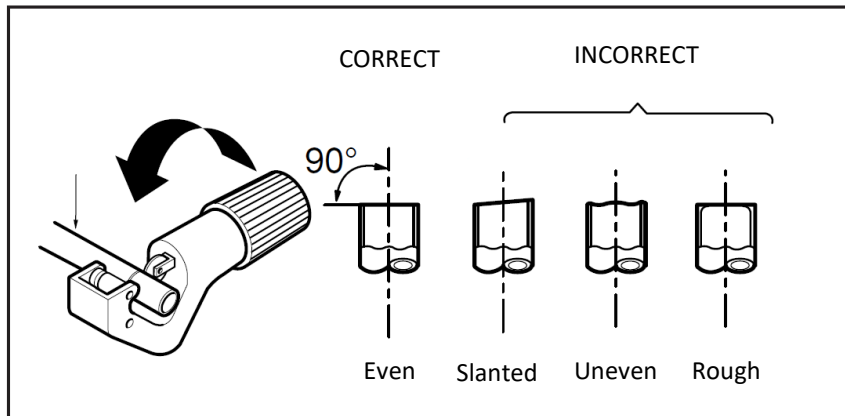

Pressure test / Air purging

Sometimes bits of air and moisture remains in the refrigerant circuit. If this is not treated, following symptoms may appear on your heat pump:

1. Pressure in the system rises.
2. Operating current rises.
3. Heating or cooling efficiency drops.
4. Blockage of capillary tube due to frozen moisture resulting in complete failure of the heat pump.
5. Corrosion of refrigerant circuit.

It is thus highly advised to take a leak test after evacuating the complete system. Leak test can be performed with usual methods using manifold valve and/or soap water. Air purging can be performed by most commonly applied methods with vacuum pump. This Installation and user manual elaborates vacuum pump method.



When the condensing unit is pre-charged with refrigerant we do not recommend a pressure test using nitrogen.



Air purging with vacuum pump

1. Preparation
 - a. Check that each tube (both liquid and gas) between the water and condensing units have been properly connected and all wiring for the test run has been completed.
 - b. Remove the service valve caps from both the gas and the liquid side on the condensing unit. Please note that both the liquid and the gas side service valves on

the condensing unit are kept closed at this stage. Some heat pumps models have in their refrigerant circuit only 1 service valve installed.

2. Lead test by vacuuming

- a. Connect the charge hose end described in the preceding steps to the vacuum pump to evacuate the tubing and water unit. Confirm the "Lo" knob of the manifold valve is open. Then, run the vacuum pump. The operation time for evacuation varies with tubing length and capacity of the pump. The following table shows the time required for evacuation when using a vacuum pump of 30 gal/h power.

Required time for evacuation when 30 gal/h vacuum pump model is used	
Tube length less than 10m	Tube length more than 10m
Minimum 10 minutes	Minimum 15 minutes

- b. When the desired vacuum is reached, close the "Lo" knob of the manifold valve and stop the vacuum pump.

Finishing the job

1. With a service valve wrench (inbus wrench), turn the valve stem of liquid side valve counter-clockwise to fully open the valve.
2. Turn the valve stem of gas side valve counter-clockwise to fully open the valve.
3. Remove the charging hoses.
4. Put service valve caps back at both gas and liquid side service valves and fasten them tight. This completes air purging with a vacuum pump and refrigerant works.



Please note that above flaring and refrigerant work must be performed correctly with utmost care. Any non-compliance with above may and will likely lead into heat pump's malfunction, failure or damage. Such state means complete warranty void and manufacturer; distributor or reseller cannot be taken responsible in such case for any property or personal damage or loss.

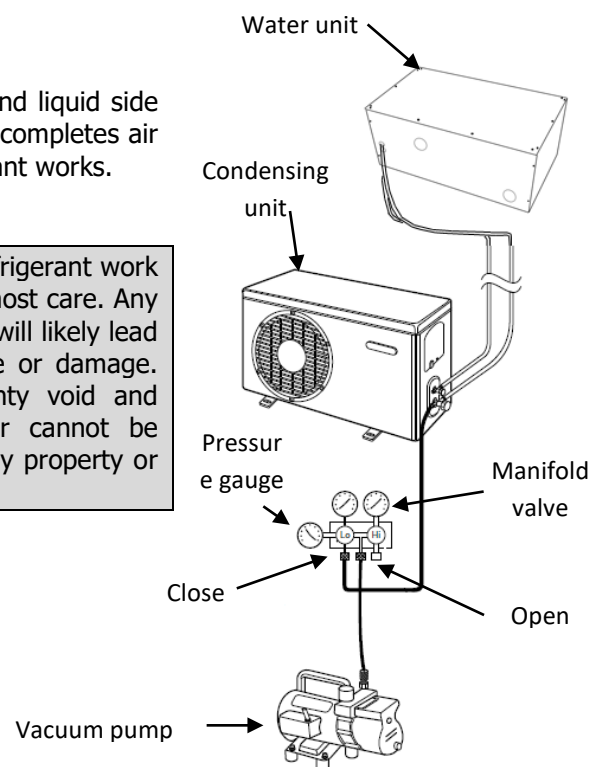

Water unit dimensions

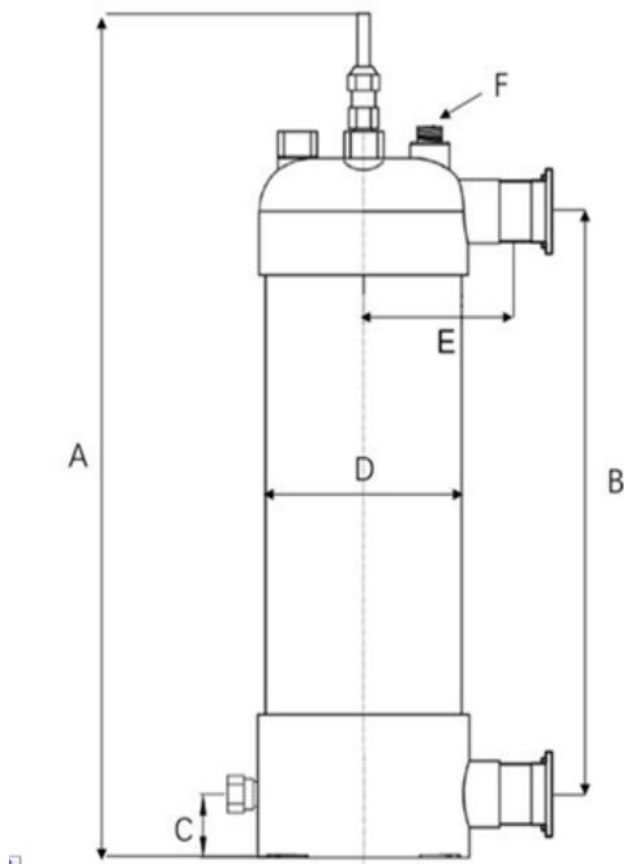

mm	A	B	C	D	E	F
HP1000 Green	505	310	60	∅140	130	G3/4" external thread
HP1400 Green	594	380	60	∅140	130	G3/4" external thread
HP1700 Green	594	380	60	∅140	130	G3/4" external thread

7. MAINTANANCE & WARRANTY

7.1 Maintenance



“CUT OFF” power supply of the heater before cleaning, examination and repairing

1. In winter season when you don't swim:
 - a. Cut off power supply to prevent any machine damage.
 - b. Drain water clear of the machine.

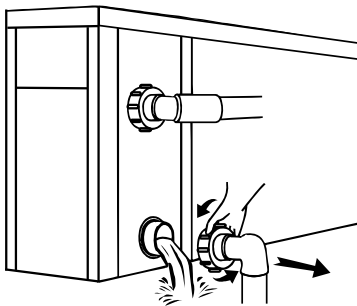

!!Important:

Unscrew the water nozzle of inlet pipe to let the water flow out.

When the water in machine freezes in winter season, the titanium heat exchanger may be damaged.

- c. Cover the machine body when not in use.
2. Please clean this machine with household detergents or clean water, NEVER use gasoline, thinners or any similar fuel.
3. Check bolts, cables and connections regularly.
4. If repair or scrap is required, please contact authorized service center nearby.
5. Do not attempt to work on the equipment by yourself. Improper operation may cause danger.
6. In case of risking, safety inspection must be carried before the maintenance or repairing for heat pumps with R32 gas.

7.2 Warranty

Your heat pump is covered by warranty. For particular conditions of this warranty in terms of warranty period and subject please refer to your local regulations and/or agreement with your distributor, reseller or installer. Any action resulting in damage of the heat pump, property or other damage caused by improper usage of this product or in contrary with this Installation and user manual is excluded from warranty coverage.

NOTES:



Distributed by:



Manufacturer:

MICROWELL, spol. s r.o.
SNP 2018/42, 927 01 Sala, Slovakia



tel.: +421/31/702 0540

fax: +421/31/702 0542



e-mail: microwell@microwell.sk

www.microwell.eu

