

THISION L PLUS



THISION L PLUS

**Gas Condensing Wall Hung Boiler
Single Installations (60 to 200 kW)
Cascade Installations up to 1600 kW**

Contents

Gas condensing boiler	Models and output.....	5
	Application possibilities	5
	Value propositions.....	5
Technical description		
	Sales text.....	6
	Technical data.....	14
	Dimensions single engine.....	16
	Dimensions double engine	17
	Boiler transport and unpacking.....	18
	Boiler standard delivery.....	19
	Cascade installation	20
	Dimensions cascade - Wall mounted	21
	Dimensions cascade - Freestanding in line	23
	Dimensions cascade - Freestanding Back to Back.....	25
	Clearances single boiler	27
	Declaration of conformity	28
Norms and regulations	General regulations	29
	Water quality.....	31
	System water additives.....	32
Flue gas system	Requirements and regulations.....	34
	Certified flue gas systems	35
	Materials.....	36
	Flue gas data.....	36
	Dimensioning single	36
	Collective flue gas systems	37
Boiler installation	Electrical connections.....	43

Contents

Standard schemes	Standard schemes 56
Accessories	Controls
	Single boiler Gas
	Single boiler Hydraulics
	Single boiler Others
	Cascade Frame
	Cascade Gas
	Cascade Hydraulics
	Cascade Specifically for Italy
	Cascade Flue

Gas condensing boiler THISION L PLUS

Models and output

Application possibilities

Value propositions

Models and output

The THISION L PLUS is a condensing and modulating gas boiler with one or two pre-mix burners and available in 7 types within an output range from 60 to 200 kW.

Application possibilities

The THISION L PLUS is applicable for all central heating systems built according to EN12828 with a maximum target temperature of 90°C.

In cascade applications (max. 8 boilers with boiler/cascade controller) the THISION L PLUS can cover installations up to 1600 kW.

Preferred applications are central heating and sanitary hot water production in multi-family buildings, municipal and industrial buildings.

Value propositions

A large modulation range that guarantees along

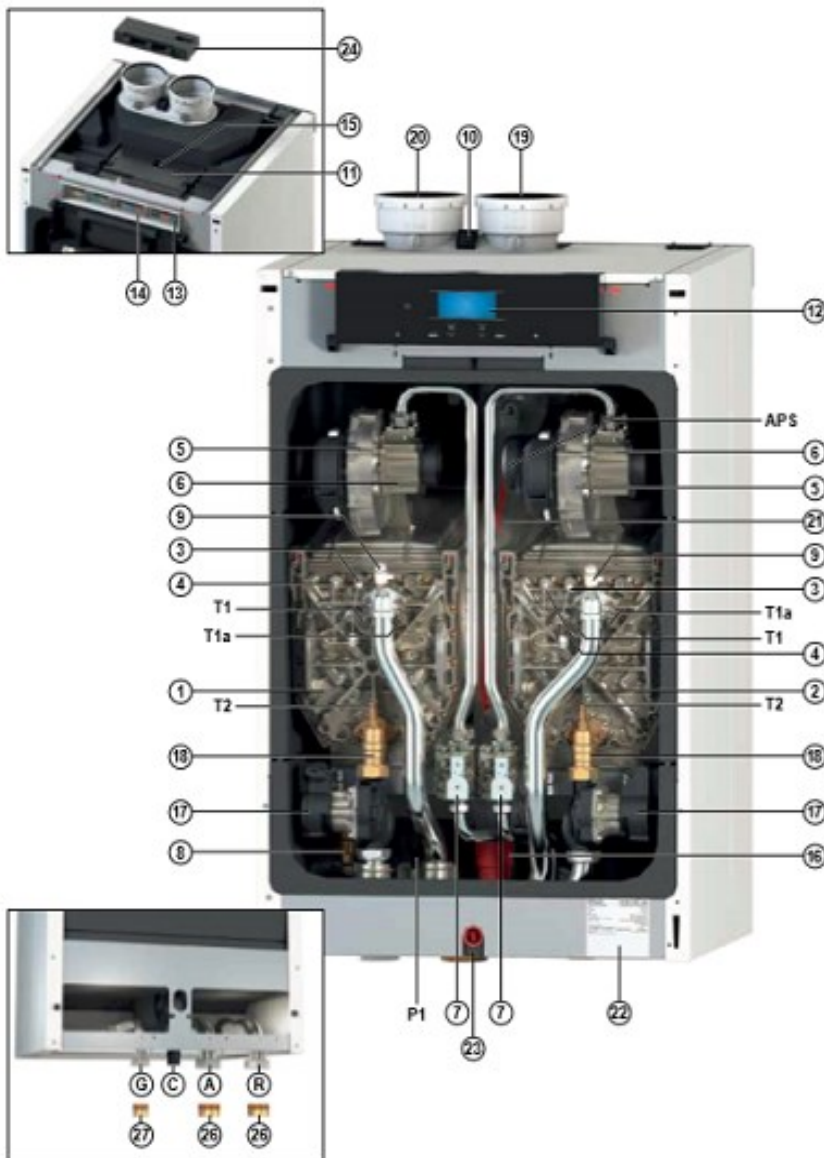

Description

The THISION L PLUS is a fully modulating condensing boiler with one or two pre-mix burners. The control unit of the boiler adapts the modulation ratio automatically to the heat demand requested by the system. This is done by controlling the speed of the fan. As a result, the mixing system will adapt the gas ratio to the chosen fan speed, in order to maintain the best possible combustion figures and therefore with the best efficiency. The flue gases created by the combustion are transported downwards through the heat exchanger and leave at the boiler at the top into the chimney connection.

The return water from the system enters the boiler in the lower section, where is the lowest flue gas temperature in the boiler. In this section condensation takes place. The water is being transported upwards through the heat exchanger, in order to leave the boiler at the flow connection. The cross flow working principle (water up, flue gas down) ensures the most efficient combustion results.

Gas condensing boiler THISION L PLUS

Models and output

Application possibilities

Value propositions

Legend

1. Heat Exchanger 1 (see table 1)
2. Heat Exchanger 2 (see table 1)
3. Ignition electrode
4. Detection electrode
5. Fan unit
6. Venturi
7. Gas valve
8. Automatic air vent
9. Manual air vent
10. Main switch 230V
11. Boiler control unit
12. Control unit MMI

Legend

13. Connection terminal
14. Connection terminal cascade bus communication
15. Connection terminal pc
16. Dirt collector
17. Circulation pump
18. Water non return valve
19. Flue connection
20. Air supply
21. Collective flue pipe
22. Information plate
23. Drainage cap
24. Clip 3 zone (optional)

Legend

25. Air / flue connection concentric (optional for Thision L Plus 60-70-100-120-140)
26. Water pipe connection reduction 1 1/2" (optional)
27. Gas pipe connection reduction 1" (optional)
- T1 Flow sensor
- T1a Secondary flow sensor
- T2 Return sensor
- P1 Water pressure sensor
- APS Air pressure switch

Legend

- G Gas Pipe
 A Flow pipe CH
 R Return pipe CH
 C Condansate drain pipe

Boiler Type	Exchanger 1	Exchanger 2
60	iCon XL 1	-
70	iCon XL 1	-
100	iCon XL 2	-
120	iCon XL 1	iCon XL 1
140	iCon XL 1	iCon XL 1
170	iCon XL 2	iCon XL 1
200	iCon XL 2	iCon XL 2

Table 1

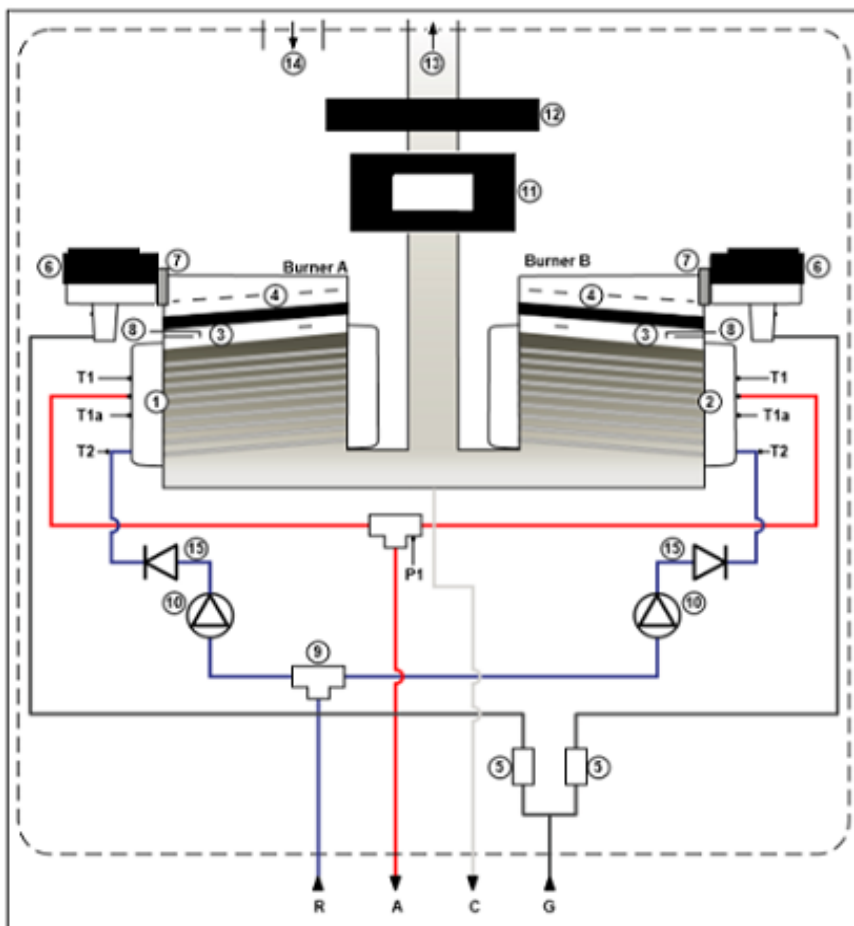

Legend

1. Heat Exchanger 1 = Burner A
2. Heat Exchanger 1 = Burner B
3. Ignition
4. Ceramic burner
5. Gas valve
6. Fan
7. Flue non-return valve
8. Venturi
9. Automatic air vent
10. Circulation pump
11. Control unit MMI
12. Burner control unit
13. Flue gas out
14. Air inlet
15. Water non-return valve
- T1 Flow Sensor
- T1a Secondary flow sensor
- T2 Return sensor
- P1 Water pressure sensor
- G Gas pipe
- A Flow pipe
- R Return pipe
- C Condensate drain pipe

Technical description

Sales text ELCO THISION L PLUS 60

ELCO THISION L PLUS 60

Wall-hung condensing gas boiler

Overview of features:

- compact, pre-assembled construction and ready for connection
- stainless steel heat exchanger
- Insulation in expanded polypropylene
- premixed burner in material ceramic for continuous adjustment of power
- Control unit ACP for combustion management, modulation and safety pump modulation management and flow measurement via the ACP unit
- combustion control with the ionization principle
- automatic temperature control
- 0-10 V DC input for connection to an external regulation system
- alarm output or operating status
- connections for the flow probe of the heating circuit, DHW and external probe
- ACP control unit with LCD display capacitive touch with led indication status: active / standby / lock, operating mode selection DHW or central heating, cascade manager integrated, chimney sweep mode with power selection minimum / maximum regardless of outside temperature, regulation of the heating flow temperature, DHW temperature regulation, e-bus2 connections for connection with accessories from the Elco offer
- Ready for connection to BMS systems supported protocols Modbus, bacnet, Lonworks, KNX with dedicated accessory
- Ready for systems management, solar thermal through dedicated accessory
- Possibility of pump management DHW circuit via diverter valve or storage heating pump, single heating zone management via power supply pump and modulation
- Operating hours counter, alarm and fault history
- support for wall mounting included
- automatic air vent valve
- flue non return valve
- modulating pump pre-mounted in the boiler modulating with flow measurement and diagnostics

Nominal thermal power at full load

with 80/60°C: 57.0 kW

with 50/30°C: 62.6 kW

Nominal heat input full load Net: 57.9 kW

Gross seasonal efficiency: 96%

Type of gas: natural gas

Gas inlet pressure max/min: 25-17mbar

NOx: < 24 mg/kWh

BREEAM credits: 2

Electrical connection: 230 V (50 Hz)

Dimensions (HxWxD): 1050x530x595 mm

Weight: 73 kg

Fittings

- air / flue gas: 100/100 mm

- water: R 2 "

- gas: R 1/2 "

Efficiency class: A / A

SSIGA approval:

Technical description

Sales text ELCO THISION L PLUS 70

ELCO THISION L PLUS 70

Wall-hung condensing gas boiler

Overview of features:

- compact, pre-assembled construction and ready for connection
- stainless steel heat exchanger
- Insulation in expanded polypropylene
- premixed burner in material ceramic for continuous adjustment of power
- Control unit ACP for combustion management, modulation and safety pump modulation management and flow measurement via the ACP unit
- combustion control with the ionization principle
- automatic temperature control
- 0-10 V DC input for connection to an external regulation system
- alarm output or operating status
- connections for the flow probe of the heating circuit, DHW and external probe
- ACP control unit with LCD display capacitive touch with led indication status: active / standby / lock, operating mode selection DHW or central heating, cascade manager integrated, chimney sweep mode with power selection minimum / maximum regardless of outside temperature, regulation of the heating flow temperature, DHW temperature regulation, e-bus2 connections for connection with accessories from the Elco offer
- Ready for connection to BMS systems supported protocols Modbus, bacnet, Lonworks, KNX with dedicated accessory
- Ready for systems management, solar thermal through dedicated accessory
- Possibility of pump management DHW circuit via diverter valve or storage heating pump, single heating zone management via power supply pump and modulation
- Operating hours counter, alarm and fault history
- support for wall mounting included
- automatic air vent valve
- flue non return valve
- modulating pump pre-mounted in the boiler modulating with flow measurement and diagnostics

Nominal thermal power at full load

with 80/60°C: 65.3 kW

with 50/30°C: 72.0 kW

Nominal heat input full load Net: 66.7 kW

Gross seasonal efficiency: 95,8%

Type of gas: natural gas

Gas inlet pressure max/min: 25-17mbar

NOx: < 24 mg/kWh

BREEAM credits: 2

Electrical connection: 230 V (50 Hz)

Dimensions (HxWxD): 1100x530x595 mm

Weight: 73 kg

Fittings

- air / flue gas: 100/100 mm

- water: R 2 "

- gas: R 1/2 "

Efficiency class: A / A

For water quality information refer to the instruction booklet

Technical description

Sales text ELCO THISION L PLUS 100

ELCO THISION L PLUS 100

Wall-hung condensing gas boiler

Overview of features:

- compact, pre-assembled construction and ready for connection
- stainless steel heat exchanger
- Insulation in expanded polypropylene
- premixed burner in material ceramic for continuous adjustment of power
- Control unit ACP for combustion management, modulation and safety pump modulation management and flow measurement via the ACP unit
- combustion control with the ionization principle
- automatic temperature control
- 0-10 V DC input for connection to an external regulation system
- alarm output or operating status
- connections for the flow probe of the heating circuit, DHW and external probe
- ACP control unit with LCD display capacitive touch with led indication status: active / standby / lock, operating mode selection DHW or central heating, cascade manager integrated, chimney sweep mode with power selection minimum / maximum regardless of outside temperature, regulation of the heating flow temperature, DHW temperature regulation, e-bus2 connections for connection with accessories from the Elco offer
- Ready for connection to BMS systems supported protocols Modbus, bacnet, Lonworks, KNX with dedicated accessory
- Ready for systems management, solar thermal through dedicated accessory
- Possibility of pump management DHW circuit via diverter valve or storage heating pump, single heating zone management via power supply pump and modulation
- Operating hours counter, alarm and fault history
- support for wall mounting included
- automatic air vent valve
- flue non return valve
- modulating pump pre-mounted in the boiler modulating with flow measurement and diagnostics

Nominal thermal power at full load

with 80/60°C: 89.4 kW

with 50/30°C: 99.0 kW

Nominal heat input full load Net: 92.3 kW

Gross seasonal efficiency: 95,2%

Type of gas: natural gas

Gas inlet pressure max/min: 25-17mbar

NOx: < 24 mg/kWh

BREEAM credits: 2

Electrical connection: 230 V (50 Hz)

Dimensions (HxWxD): 1050x530x675 mm

Weight: 80 kg

Fittings

- air / flue gas: 100/100 mm

- water: R 2 "

- gas: R 1/2 "

Efficiency class: A / A

SSIGA approval:

For water quality information refer to the instruction booklet

Technical description

Sales text ELCO THISION L PLUS 120

ELCO THISION L PLUS 120
Wall-hung condensing gas boiler

Overview of features:

- compact, pre-assembled construction and ready for connection
- stainless steel heat exchanger
- Insulation in expanded polypropylene
- premixed burner in material ceramic for continuous adjustment of power
- Control unit ACP for combustion management, modulation and safety pump modulation management and flow measurement via the ACP unit
- combustion control with the ionization principle
- automatic temperature control
- 0-10 V DC input for connection to an external regulation system
- alarm output or operating status
- connections for the flow probe of the heating circuit, DHW and external probe
- ACP control unit with LCD display capacitive touch with led indication status: active / standby / lock, operating mode selection DHW or central heating, cascade manager integrated, chimney sweep mode with power selection minimum / maximum regardless of outside temperature, regulation of the heating flow temperature, DHW temperature regulation, e-bus2 connections for connection with accessories from the Elco offer
- Ready for connection to BMS systems supported protocols Modbus, bacnet, Lonworks, KNX with dedicated accessory
- Ready for systems management, solar thermal through dedicated accessory
- Possibility of pump management DHW circuit via diverter valve or storage heating pump, single heating zone management via power supply pump and modulation
- Operating hours counter, alarm and fault history
- support for wall mounting included
- automatic air vent valve
- flue non return valve
- modulating pump pre-mounted in the boiler modulating with flow measurement and diagnostics

Nominal thermal power at full load

with 80/60°C: 110.3 kW

with 50/30°C: 122.2 kW

Nominal heat input full load Net: 112.8 kW

Gross seasonal efficiency: 96.1%

Type of gas: natural gas

Gas inlet pressure max/min: 25-17mbar

NOx: < 24 mg/kWh

BREEAM credits: 2

Electrical connection: 230 V (50 Hz)

Dimensions (HxWxD): 1050x690x595 mm

Weight: 127 kg

Fittings

- air / flue gas: 100/100 mm

- water: R 2 "

- gas: R 1/2 "

For water quality information refer to the instruction booklet

Technical description

Sales text ELCO THISION L PLUS 140

ELCO THISION L PLUS 140

Wall-hung condensing gas boiler

Overview of features:

- compact, pre-assembled construction and ready for connection
- stainless steel heat exchanger
- Insulation in expanded polypropylene
- premixed burner in material ceramic for continuous adjustment of power
- Control unit ACP for combustion management, modulation and safety pump modulation management and flow measurement via the ACP unit
- combustion control with the ionization principle
- automatic temperature control
- 0-10 V DC input for connection to an external regulation system
- alarm output or operating status
- connections for the flow probe of the heating circuit, DHW and external probe
- ACP control unit with LCD display capacitive touch with led indication status: active / standby / lock, operating mode selection DHW or central heating, cascade manager integrated, chimney sweep mode with power selection minimum / maximum regardless of outside temperature, regulation of the heating flow temperature, DHW temperature regulation, e-bus2 connections for connection with accessories from the Elco offer
- Ready for connection to BMS systems supported protocols Modbus, bacnet, Lonworks, KNX with dedicated accessory
- Ready for systems management, solar thermal through dedicated accessory
- Possibility of pump management DHW circuit via diverter valve or storage heating pump, single heating zone management via power supply pump and modulation
- Operating hours counter, alarm and fault history
- support for wall mounting included
- automatic air vent valve
- flue non return valve
- modulating pump pre-mounted in the boiler modulating with flow measurement and diagnostics

Nominal thermal power at full load

with 80/60°C: 129.9 kW

with 50/30°C: 142.4 kW

Nominal heat input full load Net: 133.2 kW

Gross seasonal efficiency: 95.1%

Type of gas: natural gas

Gas inlet pressure max/min: 25-17mbar

NOx: < 24 mg/kWh

BREEAM credits: 2

Electrical connection: 230 V (50 Hz)

Dimensions (HxWxD): 1050x690x595 mm

Weight: 127 kg

Fittings

- air / flue gas: 100/100 mm

- water: R 2 "

- gas: R 1/2 "

For water quality information refer to the instruction booklet

Technical description

Sales text ELCO THISION L PLUS 170

ELCO THISION L PLUS 170

Wall-hung condensing gas boiler

Overview of features:

- compact, pre-assembled construction and ready for connection
- stainless steel heat exchanger
- Insulation in expanded polypropylene
- premixed burner in material ceramic for continuous adjustment of power
- Control unit ACP for combustion management, modulation and safety pump modulation management and flow measurement via the ACP unit
- combustion control with the ionization principle
- automatic temperature control
- 0-10 V DC input for connection to an external regulation system
- alarm output or operating status
- connections for the flow probe of the heating circuit, DHW and external probe
- ACP control unit with LCD display capacitive touch with led indication status: active / standby / lock, operating mode selection DHW or central heating, cascade manager integrated, chimney sweep mode with power selection minimum / maximum regardless of outside temperature, regulation of the heating flow temperature, DHW temperature regulation, e-bus2 connections for connection with accessories from the Elco offer
- Ready for connection to BMS systems supported protocols Modbus, bacnet, Lonworks, KNX with dedicated accessory
- Ready for systems management, solar thermal through dedicated accessory
- Possibility of pump management DHW circuit via diverter valve or storage heating pump, single heating zone management via power supply pump and modulation
- Operating hours counter, alarm and fault history
- support for wall mounting included
- automatic air vent valve
- flue non return valve
- modulating pump pre-mounted in the boiler modulating with flow measurement and diagnostics

Nominal thermal power at full load

with 80/60°C: 154.4 kW

with 50/30°C: 170.9 kW

Nominal heat input full load Net: 158.8 kW

Gross seasonal efficiency: 95.5%

Type of gas: natural gas

Gas inlet pressure max/min: 25-17mbar

NOx: < 24 mg/kWh

BREEAM credits: 2

Electrical connection: 230 V (50 Hz)

Dimensions (HxWxD): 1050x690x595 mm

Weight: 132 kg

Fittings

- air / flue gas: 130/130 mm

- water: R 2 "

- gas: R 1/2 "

For water quality information refer to the instruction booklet

Technical description

Sales text ELCO THISION L PLUS 200

ELCO THISION L PLUS 200

Wall-hung condensing gas boiler

Overview of features:

- compact, pre-assembled construction and ready for connection
- stainless steel heat exchanger
- Insulation in expanded polypropylene
- premixed burner in material ceramic for continuous adjustment of power
- Control unit ACP for combustion management, modulation and safety pump modulation management and flow measurement via the ACP unit
- combustion control with the ionization principle
- automatic temperature control
- 0-10 V DC input for connection to an external regulation system
- alarm output or operating status
- connections for the flow probe of the heating circuit, DHW and external probe
- ACP control unit with LCD display capacitive touch with led indication status: active / standby / lock, operating mode selection DHW or central heating, cascade manager integrated, chimney sweep mode with power selection minimum / maximum regardless of outside temperature, regulation of the heating flow temperature, DHW temperature regulation, e-bus2 connections for connection with accessories from the Elco offer
- Ready for connection to BMS systems supported protocols Modbus, bacnet, Lonworks, KNX with dedicated accessory
- Ready for systems management, solar thermal through dedicated accessory
- Possibility of pump management DHW circuit via diverter valve or storage heating pump, single heating zone management via power supply pump and modulation
- Operating hours counter, alarm and fault history
- support for wall mounting included
- automatic air vent valve
- flue non return valve
- modulating pump pre-mounted in the boiler modulating with flow measurement and diagnostics

Nominal thermal power at full load

with 80/60°C: 179.1 kW

with 50/30°C: 197.4 kW

Nominal heat input full load Net: 184.5 kW

Gross seasonal efficiency: 95%

Type of gas: natural gas

Gas inlet pressure max/min: 25-17mbar

NOx: < 24 mg/kWh

BREEAM credits: 2

Electrical connection: 230 V (50 Hz)

Dimensions (HxWxD): 1050x690x595 mm

Weight: 140 kg

Fittings

- air / flue gas: 130/130 mm

- water: R 2 "

- gas: R 1/2 "

For water quality information refer to the instruction booklet

Technical description

Technical data ErP data

TRIGON L PLUS					60	70	100
Permit					CE0063CT3449		
Category					GB: II2H3P		
Heat exchanger type					iConXL1	iConXL1	iConXL2
Output	G20	Full load	80/60°C	kW	56,9	65,4	90,2
			40/30°C	kW	62,6	72,0	99,0
		Low load	80/60°C	kW	14,7	14,6	18,1
			40/30°C	kW	16,1	16,1	19,9
	G31	Full load	80/60°C	kW	56,9	65,4	90,2
			40/30°C	kW	62,6	72,0	99,0
		Low load	80/60°C	kW	23,3	23,2	34,3
			40/30°C	kW	25,6	25,6	37,7
Input	G20	Full load		kW	57,9	66,7	92,3
		Low load		kW	14,9	14,9	18,5
	G31	Full load		kW	57,9	66,7	92,3
		Low load		kW	23,6	23,6	35,0
Gas consumption	G20	Full load		m ³ /h	6,1	7,1	9,8
		Low load		m ³ /h	1,6	1,6	2,0
	G31	Full load		kg/h	4,7	5,5	7,6
		Low load		kg/h	1,92	1,92	2,84
Boiler efficiency		Full load	80/60°C	%	98,2	98,0	97,7
		Full load	40/30°C	%	108,1	108,0	107,3
		Low load	80/60°C	%	98,5	98,3	97,9
		Low load	40/30°C	%	108,5	108,4	107,6
Gas type					Natural gas or Gas propane		
CO ₂ natural gas	min./max			Vol. %	8,7 / 9,3		
CO ₂ propane gas	min./max			Vol. %	10,2 / 10,8		
O ₂ natural gas	min./max			Vol. %	5,3 / 4,3		
NO _x class					6	6	6
Max. flue gas temperature				80/60°C	62	61	71
Mass flow of flue gas				kg/h	104	120	166
Overpressure at boiler output	max			Pa	161	156	243
Water content	max			l	9,3	9,3	13,9
Weight				kg	73	73	80
Gas flow pressure - standard				mbar	20		
Gas flow-pressure min./max.				mbar	17 / 25		
Water pressure	min./max			bar	0,7 / 6		
Voltage/frequency	min./max			Volt/Hz	230 / 50		
Max. power consumption				W	126	137	120
Power consumption part load				W	81	45	95
Power consumption stand by				W	5	5	5
Width / depth / height				mm	530/595/1050	530/595/1050	530/675/1050
Gas external thread				R	Rp 1.1/4"	Rp 1.1/4"	Rp 1.1/4"
Flow/return external thread				R	Rp 2"	Rp 2"	Rp 2"
Flue gas connection PPS	Diameter			DN	100	100	100
Outdoor air connection	Internal			in mm	100	100	100
Condensate connection PVC	External			in mm	35,5	35,5	35,5
ErP data according to 813/2013/EU					60	70	100
Seasonal room-heating energy efficiency class					A	A	
Nominal heat output				P _n (kW)	56	64	88
Seasonal room-heating energy efficiency class				η _s (%)	93	93	93
Annual energy consumption				Q _{HE} (GJ)	174	199	272
Noise output level, inside				LWA (dB)	62	65	60
At rated heat output and high-temp regime 80/60°C				P ₄ (kW)	56,9	65,3	90,2
At 30 % of rated heat output and low-temp regime 36/30°C				P ₁ (kW)	19,0	21,8	30,2
At rated heat output and high-temp regime (GCV)				η ₄ (%)	88,4	88,2	88,0
At 30 % of rated heat output and low-temp regime (GCV)				η ₁ (%)	98,4	98,3	98,2
At full load				el _{max} (kW)	0,126	0,137	0,120
At part load				el _{min} (kW)	0,081	0,045	0,095
In standby mode				P _{sb} (kW)	0,005	0,005	0,005
Standby heat loss				P _{stby} (kw)	0,086	0,086	0,075

Technical description

Technical data ErP data

TRIGON L PLUS				120	140	170	200	
Permit	CE0063CT3449							
Category	GB: II2H3P							
Heat exchanger type				iConXL1 iConXL1	iConXL1 iConXL1	iConXL1 iConXL2	iConXL2 iConXL2	
Output	G20	Full load	80/60°C	kW	110,8	130,5	155,5	180,3
			40/30°C	kW	122,2	142,4	170,9	197,4
		Low load	80/60°C	kW	14,7	14,6	14,6	18,1
			40/30°C	kW	16,2	16,0	16,1	19,8
	G31	Full load	80/60°C	kW	110,8	130,5	155,5	180,3
			40/30°C	kW	122,2	142,4	170,9	197,4
		Low load	80/60°C	kW	23,3	23,2	23,2	34,3
			40/30°C	kW	25,7	25,3	25,5	37,6
Input	G20	Full load		kW	112,8	133,2	158,8	184,5
				kW	14,9	14,9	14,9	18,5
	G31	Full load		kW	112,8	133,2	158,8	184,5
				kW	23,6	23,6	23,6	35,0
Gas consumption	G20	Full load		m3/h	11,9	14,1	16,8	19,5
				m3/h	1,6	1,6	1,6	2,0
	G31	Full load		kg/h	9,2	10,9	13,0	15,1
				kg/h	1,92	1,92	1,92	2,84
Boiler efficiency	Full load	80/60°C	%	98,2	98,0	97,9	97,7	
		40/30°C	%	108,3	106,9	107,6	107,0	
	Low load	80/60°C	%	98,5	98,3	98,2	97,9	
		40/30°C	%	108,7	107,3	107,9	107,3	
Gas type	Natural gas or Gas propane							
CO2 natural gas	min./max		Vol. %	8,7 / 9,3				
CO2 propane gas	min./max		Vol. %	10,2 / 10,8				
O2 natural gas	min./max		Vol. %	5,3 / 4,3				
NOx class				6	6	6	6	
Max. flue gas temperature			80/60°C	62	61	72	71	
Mass flow of flue gas			kg/h	203	239	285	331	
Overpressure at boiler output	max		Pa	143	200	215	265	
Water content	max		l	16,8	16,8	21,3	25,8	
Weight			kg	127	127	132	140	
Gas flow pressure - standard			mbar	20				
Gas flow-pressure min./max.			mbar	17 / 25				
Water pressure	min./max		bar	0,7 / 6				
Voltage/frequency	min./max		Volt/Hz	230 / 50				
Max. power consumption			W	314	418	464	450	
Power consumption part load			W	66	71	109	99	
Power consumption stand by			W	6,8	6,8	6,8	6,8	
Width / depth / height			mm	690/595/1050	690/595/1050	690/675/1050	690/675/1050	
Gas external thread			R	Rp 1.1/4"	Rp 1.1/4"	Rp 1.1/4"	Rp 1.1/4"	
Flow/return external thread			R	Rp 2"	Rp 2"	Rp 2"	Rp 2"	
Flue gas connection PPS	Diameter		DN	100	100	130	130	
Outdoor air connection	Internal		in mm	100	100	130	130	
Condensate connection PVC	External		in mm	35,5	35,5	35,5	35,5	
ErP data according to 813/2013/EU				120	140	170	200	
Seasonal room-heating energy efficiency class								
Nominal heat output			Pn (kW)	108	128	152	176	
Seasonal room-heating energy efficiency class								
Annual energy consumption			QHE (GJ)	335	394	471	543	
Noise output level, inside			LWA (dB)	67	70	67	63	
At rated heat output and high-temp regime 80/60°C			P4 (kW)	110,8	130,6	155,6	180,3	
At 30 % of rated heat output and low-temp regime 36/30°C			P1 (kW)	37,0	43,7	52,0	60,4	
At rated heat output and high-temp regime (GCV)			η4 (%)	88,4	88,2	88,2	88,0	
At 30 % of rated heat output and low-temp regime (GCV)			η1 (%)	98,4	98,3	98,2	98,2	
At full load			elmax (kW)	0,314	0,418	0,464	0,450	
At part load			elmin (kW)	0,066	0,071	0,109	0,099	
In standby mode			Psb (kW)	0,007	0,007	0,007	0,007	
Standby heat loss			Pstby (kw)	0,079	0,079	0,100	0,141	

Technical description

Dimensions

Single Engine

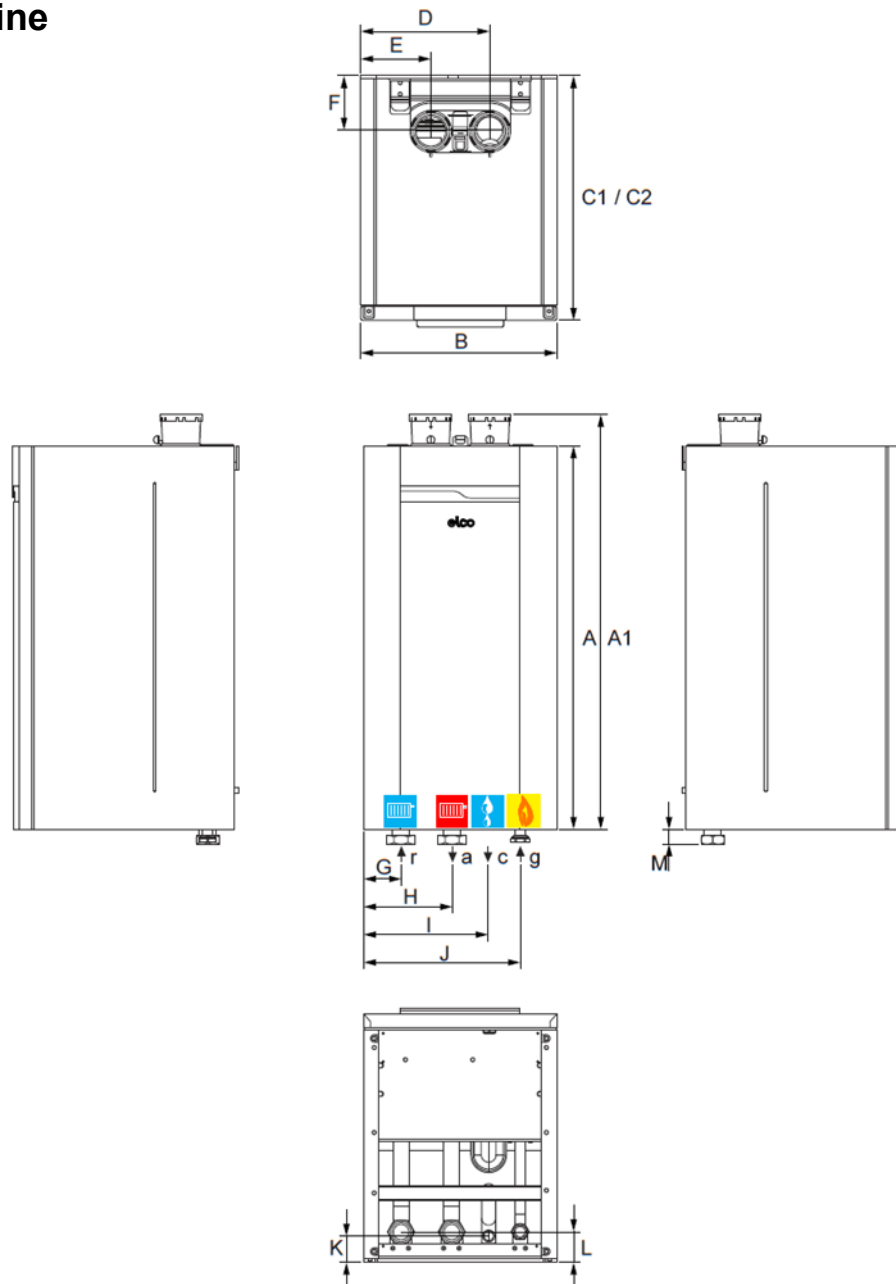

	THISION L PLUS		60-70	100
A	Height	mm	1050	1050
A1	Height + flue conn.	mm	1135	1135
B	Width	mm	530	530
C1 / C2	Depth	mm	595	675
D	Flue gas conn.	mm	345	345
E	Air intake conn.	mm	185	185
F	Flue / air intake	mm	150	150
G	Return connection	mm	103	103
H	Flow connection	mm	243	243
I	Condensate connection	mm	345	345
J	Gas connection	mm	430	430
K	Condensate connection	mm	60	60
L	Boiler return-flow-gas	mm	75	75
M	Boiler return-flow-gas	mm	25	25

	THISION L PLUS		60-70	100
	Concentric connection	mm	100/150*	100/150*
	Parallel connection	mm	2x100	2x100
g	Gas connection		1 1/4"	1 1/4"
	Gas connection**		1" **	1" **
c	Condensate connection	mm	35	35
a	Boiler flow connection		2"	2"
	Boiler flow connection**		1 1/2" **	1 1/2" **
r	Boiler return connection		2"	2"
	Boiler return conn.**		1 1/2" **	1 1/2" **

* with concentric adapter (accessory)

** with water/gas connection reduction kit (accessory)

Technical description

Dimensions

Double Engine

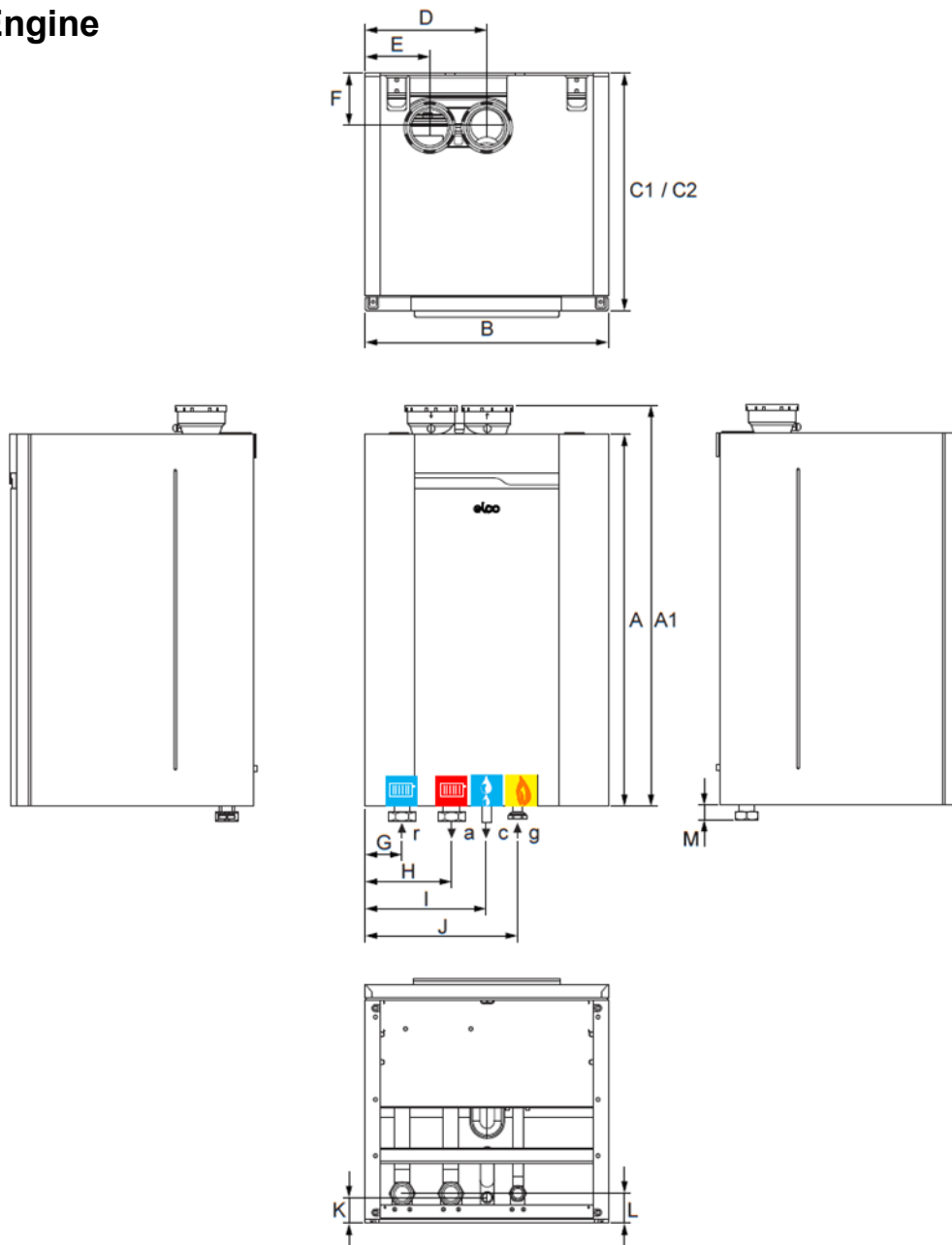

	THISION L PLUS		120-140	170-200
A	Height	mm	1050	1050
A1	Height + flue conn.	mm	1135	1135
B	Width	mm	690	690
C1 / C2	Depth	mm	595	675
D	Flue gas conn.	mm	345	345
E	Air intake conn.	mm	185	185
F	Flue / air intake	mm	150	150
G	Return connection	mm	103	103
H	Flow connection	mm	243	243
I	Condensate connection	mm	345	345
J	Gas connection	mm	430	430
K	Condensate connection	mm	60	60
L	Boiler return-flow-gas	mm	75	75
M	Boiler return-flow-gas	mm	25	25

	THISION L PLUS		120-140	170-200
	Concentric connection	mm	100/150*	-
	Parallel connection	mm	2x100	2x130
g	Gas connection		1 1/4"	1 1/4"
	Gas connection**		1" **	1" **
c	Condensate connection	mm	35	35
a	Boiler flow connection		2"	2"
	Boiler flow connection**		1 1/2" **	1 1/2" **
r	Boiler return connection		2"	2"
	Boiler return conn.**		1 1/2" **	1 1/2" **

* with concentric adapter (accessory)

** with water/gas connection reduction kit (accessory)

Technical description

Boiler transport

The THISION L PLUS is a fully equipped compact heating system, which has been pre-set and tested at the factory.

The package dimensions for all appliances are:

Width 750mm

Height 1200mm

Depth 800mm

This makes it possible to transport all models in one piece through a normal door.

The boiler can be moved using a fork-lift or pallet truck. Unpacking instructions are printed on the cardboard box. Please follow the proposed steps.

Disassembly of panelling

The appliance casing panels can be easily removed and this is recommended while the appliance is being installed. This limits the potential for damage to occur.

Lifting and carrying precautions:

- Wear protective clothing and gloves to protect from any sharp edges.
- The boiler has to be lifted from the front with a forklift truck for transport.

Panelling should be attached and secured with the supplied screw, after assembly of the boiler, or after maintenance works.

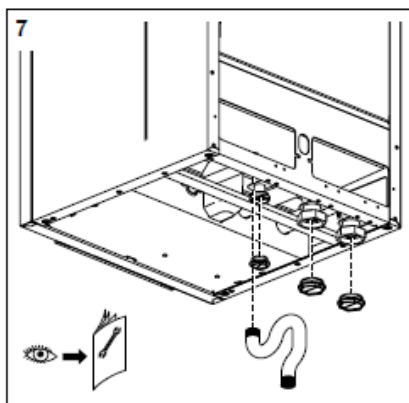
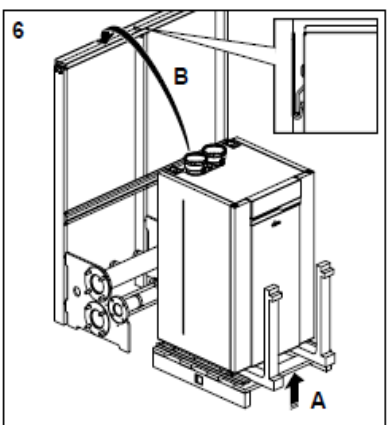
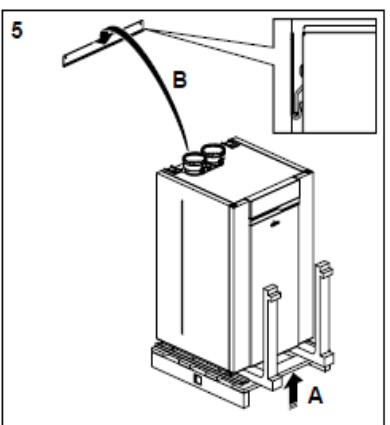
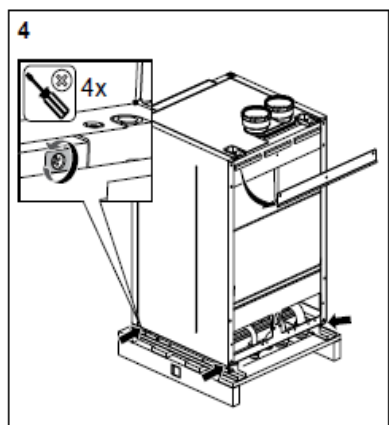
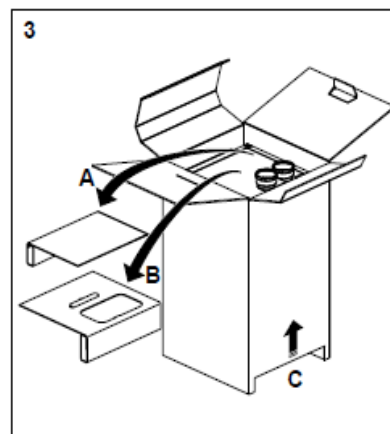
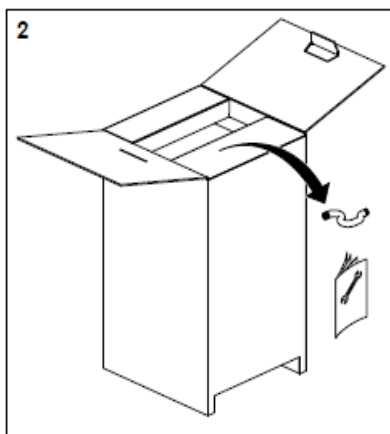
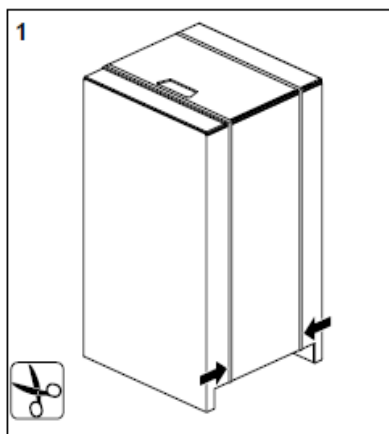

1. Remove the plastic strip.
2. Open the 4 upper folders, and remove the documentation and the condense pipe.
3. Remove the carton inserts, remove the carton box.
4. Remove the wall plate from the back of the boiler (removing one screw), and remove the 4 screws on bottom part of the boiler.
5. Install the boiler on the cascade (with a fork lifter).
6. Install the boiler on the new wall plate (with a fork lifter).
7. Remove the water and gas plastic cap, connect the condense pipe, and follow the installation manual.

Technical description

Standard boiler

Boiler transport

Boiler installation

Clearance

Standard boiler

A boiler delivery package contains the following components:

Component	Pcs.	Package
Completely assembled and tested boiler	1	In cardboard box
Mounting rail	1	In boiler packaging
Installation manual THISION L PLUS	1	In document bag in boiler packaging
ERP label (only THISION L PLUS 60-70)	1	
Condense pipe	1	

Boiler transport

The THISION L PLUS boiler will be supplied as a fully equipped compact appliance, which has been pre-set and tested. The dimensions of the packaging are : 60,70,100,120,140,170,200:800 x 1200 x 750 mm (W x H x D).

This makes it possible to transport all models in one piece through a normal door. The boiler can be picked up or from the front with a forklift truck for transport. Unpacking instructions are printed on the cardboard box. Please follow the proposed steps.

Boiler Installation

The installation location of the CH-boiler(s) has to be, and remain, frost-free. It is NOT necessary to have a purpose provided air vent providing a twin pipe or concentric room sealed flue system is used in the room or internal space in which the boiler is installed. Neither is it necessary to ventilate the compartment in which the boiler is installed, due to the extremely low surface temperature of the boiler casing during operation. The floor has to be flat and level and have sufficient deadweight capacity for the complete (filled) installation.

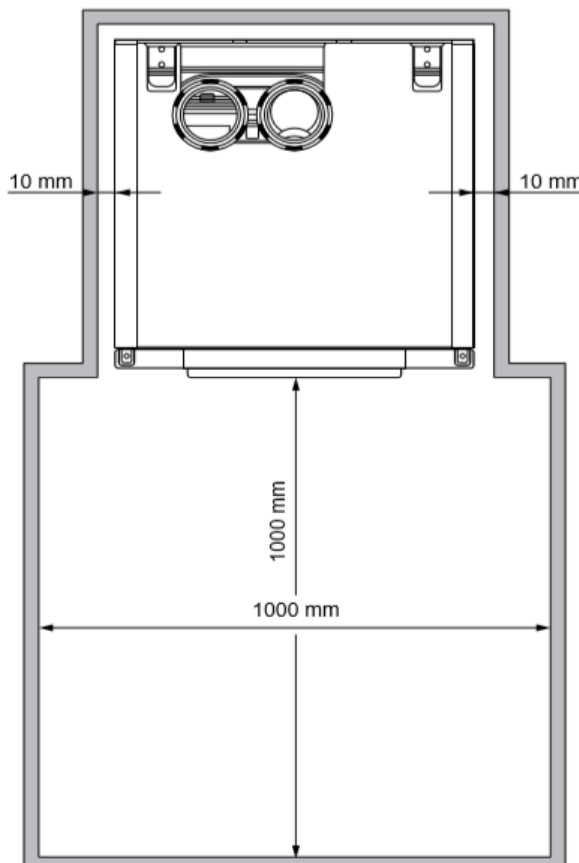

When positioning the boiler, please note the recommended minimum clearance in the picture. When the boiler is positioned with less free space, maintenance activities will be more difficult.

If you have opted to build the hydraulic part yourself, then ELCO recommends using "Connection set THISION L PLUS as single boiler" for each boiler.

Dimensions Cascade

THISION L PLUS / cascade installation

Cascade

In principle, any combination is possible depending on the installation requirements. The selection of the models can be different outputs. Including boilers with common outputs assists with sharing the load and run times of individual appliance.

The capacity of the hydraulic pipes, gas line, and low loss header are adjusted to the selected overall demand.

When installing the a single THISION L PLUS boiler or cascade THISION L PLUS boilers, the use of a low loss header adjusted to the set demand is strongly suggested. Elco Heating Solutions offer optional matched low-velocity mixing headers suitable for heat outputs up-to 1600kW.

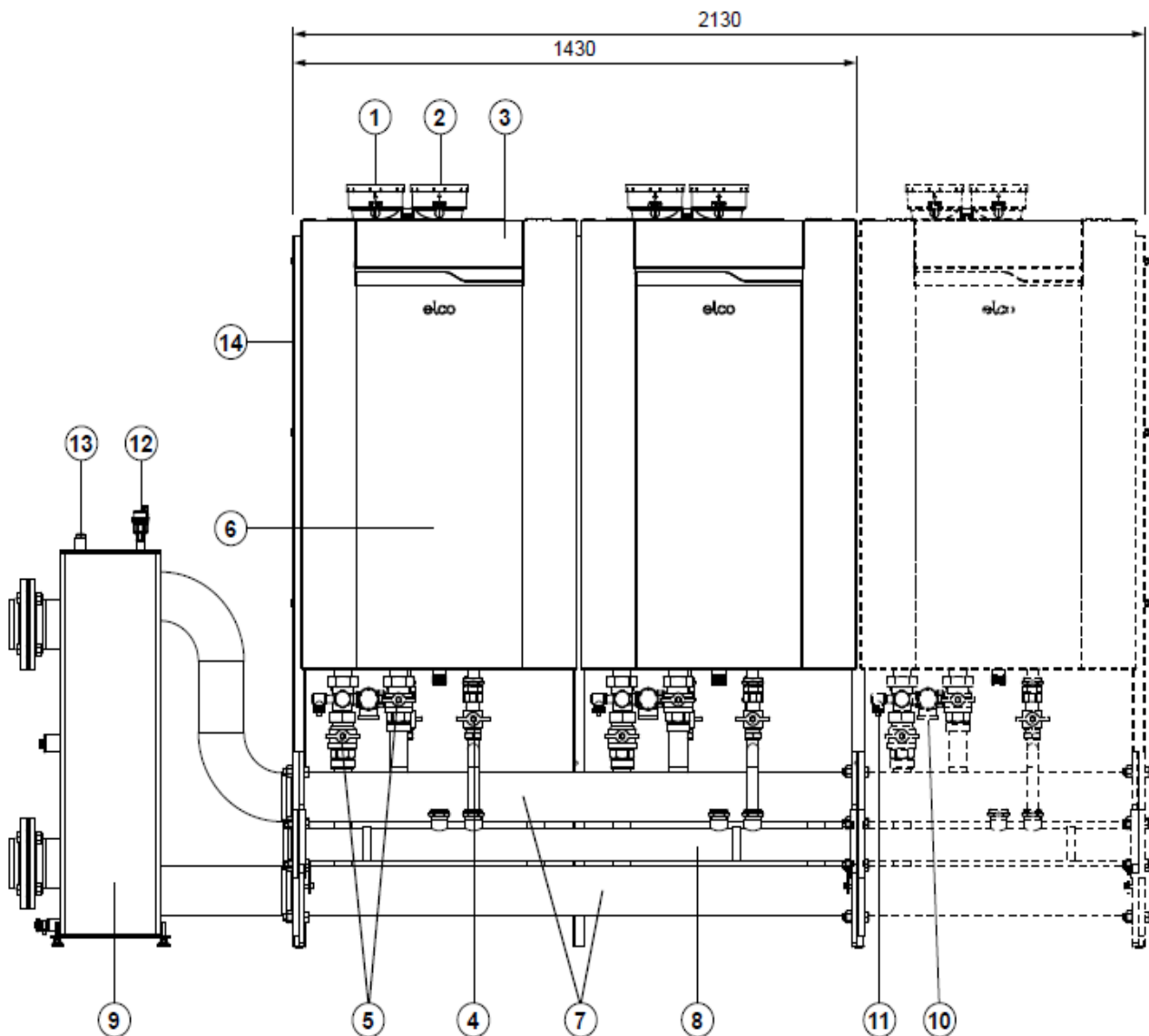

Dimensions Cascade

THISION L PLUS / cascade installation

Legend:

1. Air supply
2. Flue gas discharge/Air supply
3. Cascade manager

Accessories:

4. Gas isolation valve
5. Service valves flow and return
6. Non-return valve

Legend:

Accessories:

7. Flow / return header
8. Gas line
9. Low loss header
10. Safety valve 3 or 6 bar
11. Fill and drain valve

Legend:

Accessories:

12. Automatic air vent low loss header
13. Pocket for temperature sensor T10
14. Frame

Cascade possibilities

The ELCO THISION L PLUS cascade can be mounted in 3 ways:

- Wall-mounted in line

All boilers alongside one another on the wall

- Free-standing in line

All boilers hanging alongside one another on a free-standing frame

- Free-standing back-to-back

All boilers hanging back-to-back on a free-standing frame

THISION L PLUS Cascade examples wall-mounted

THISION L PLUS 2 boilers wall mounted in line

THISION L PLUS 3 boilers wall mounted in line

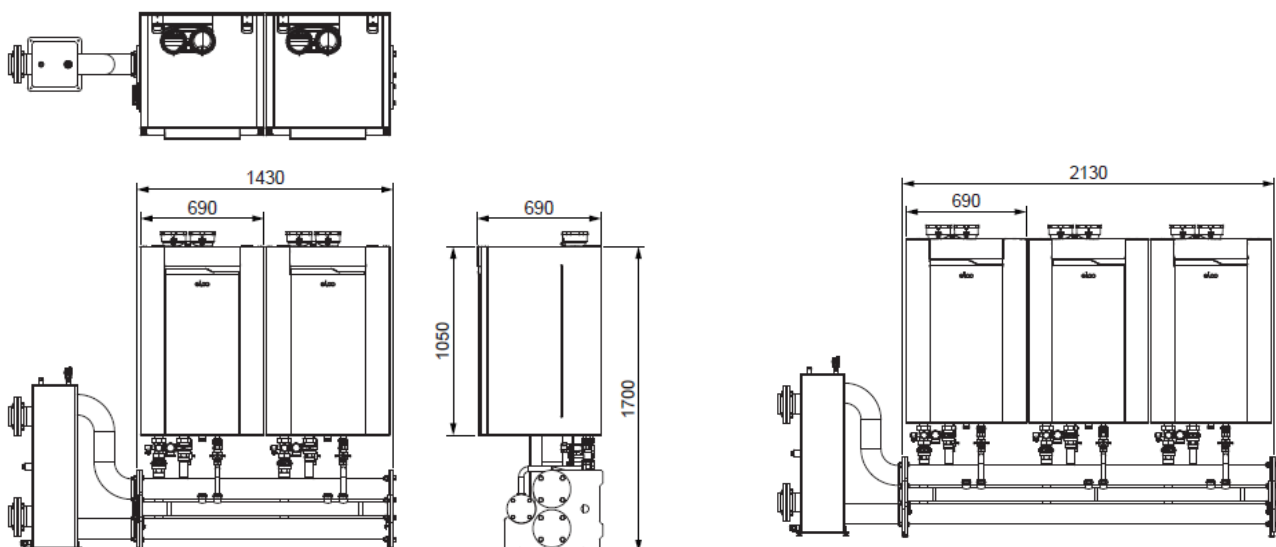

Dimensions Cascade

THISION L PLUS / Cascade installation

THISION L PLUS Cascade examples wall-mounted

THISION L PLUS 5 boilers wall mounted in line

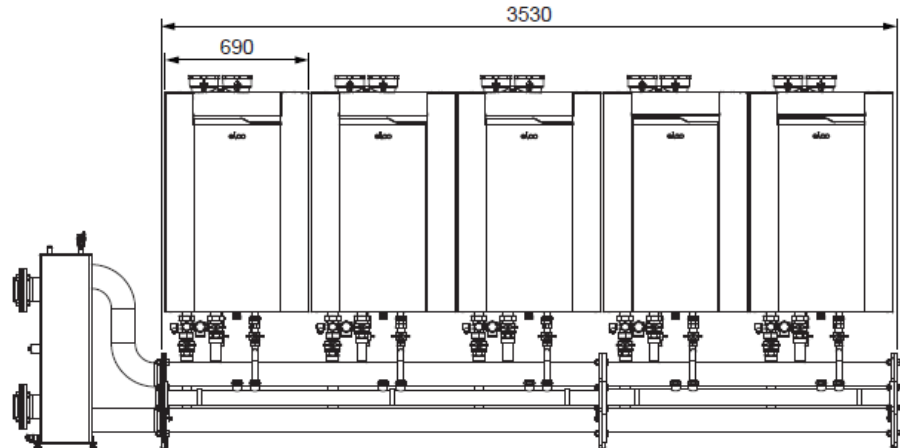

THISION L PLUS 8 boilers wall mounted in line

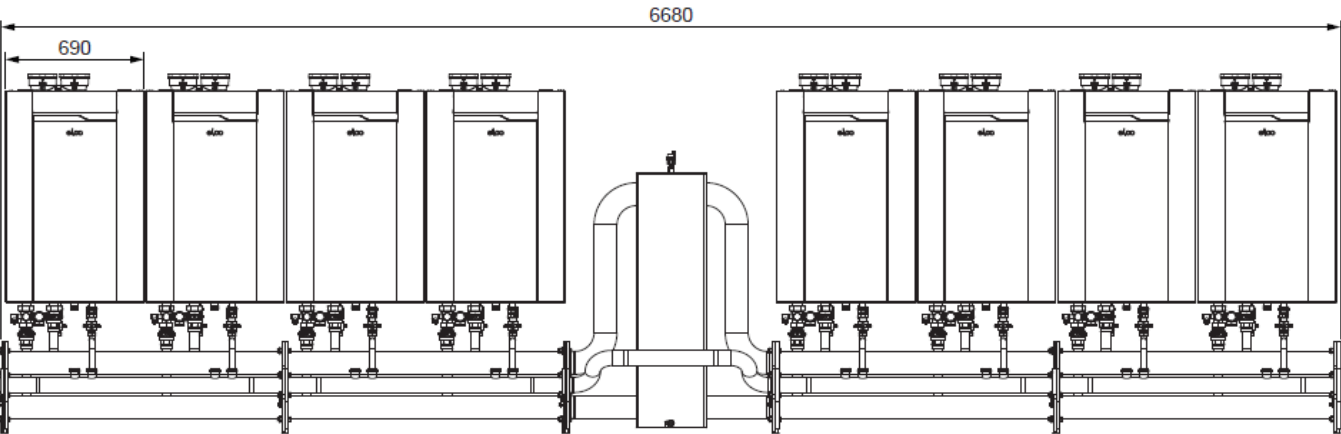

Dimensions Cascade

THISION L PLUS / Cascade installation

THISION L PLUS Cascade examples free-standing in line

THISION L PLUS 2 boilers free-standing in line

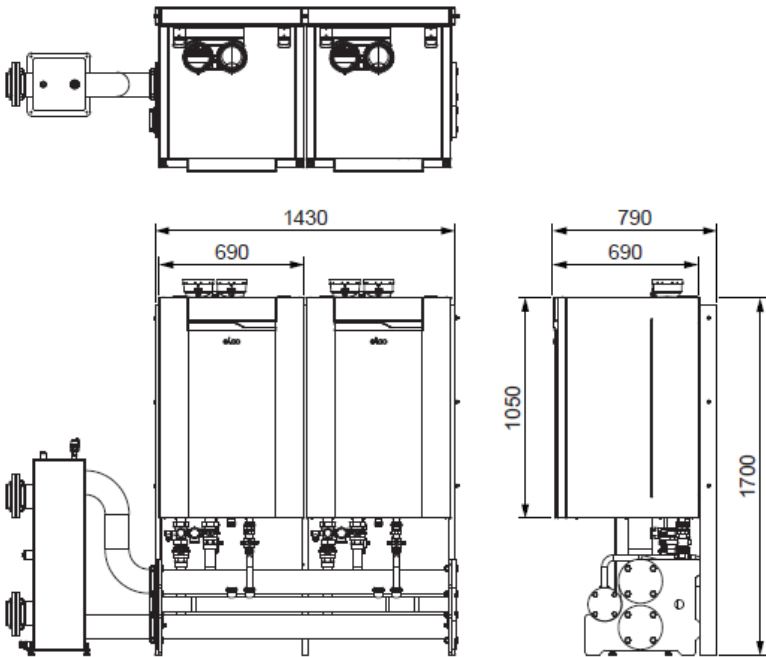

THISION L PLUS 3 boilers free-standing in line

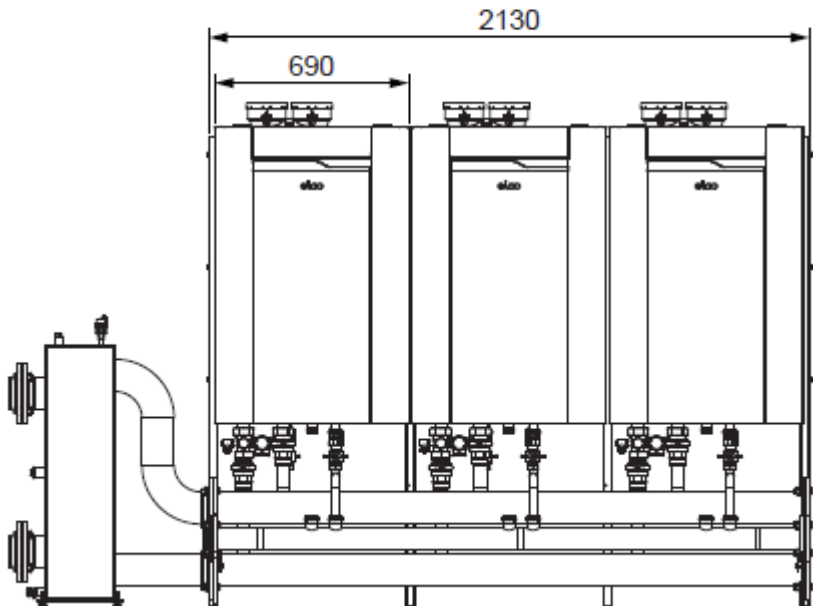

Dimensions Cascade

THISION L PLUS / Cascade installation

THISION L PLUS Cascade examples free-standing in line

THISION L PLUS 5 boilers free-standing in line

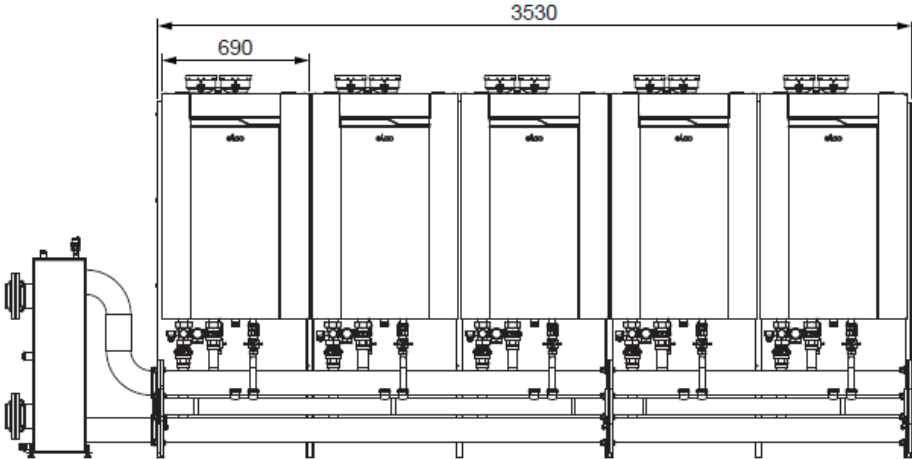

THISION L PLUS 8 boilers free-standing in line

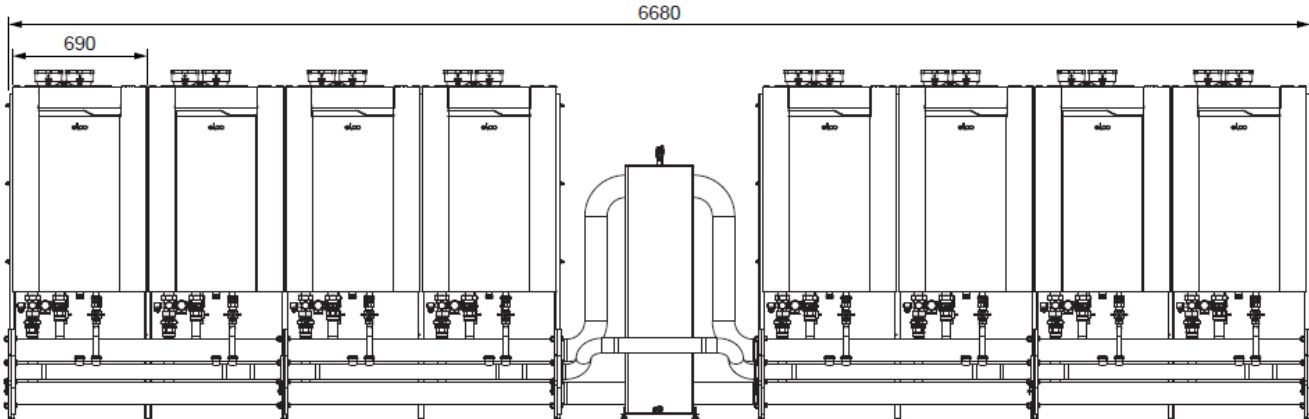

Dimensions Cascade

THISION L PLUS / Cascade installation

THISION L PLUS Cascade examples free-standing back-to-back

THISION L PLUS 3 boilers free-standing back-to-back

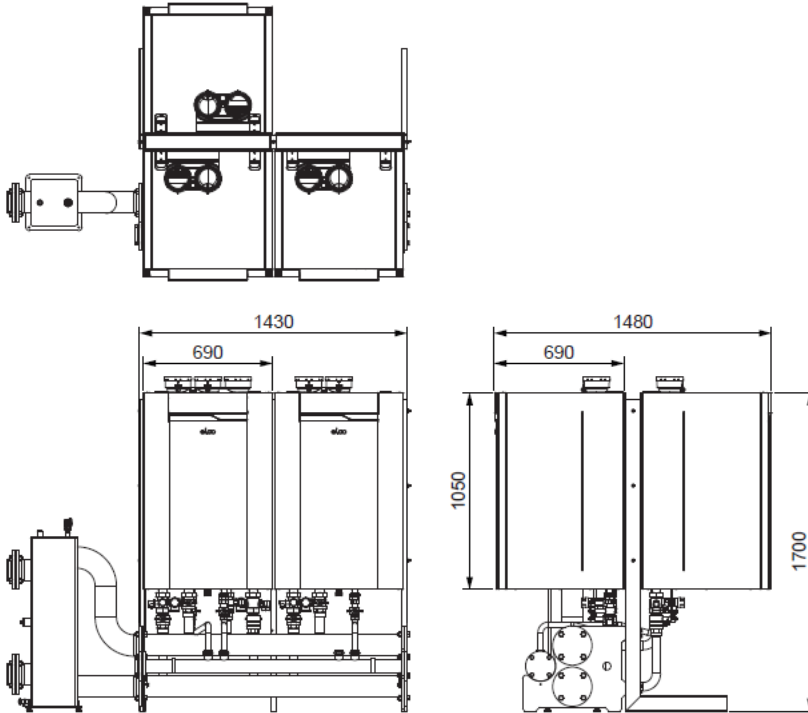

THISION L PLUS 4 boilers free-standing back-to-back

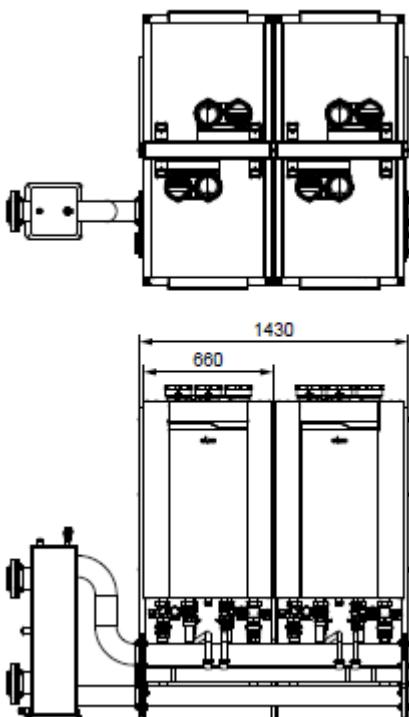

Dimensions Cascade

THISION L PLUS / Cascade installation

THISION L PLUS Cascade examples free-standing back-to-back

THISION L PLUS 6 boilers free-standing back-to-back

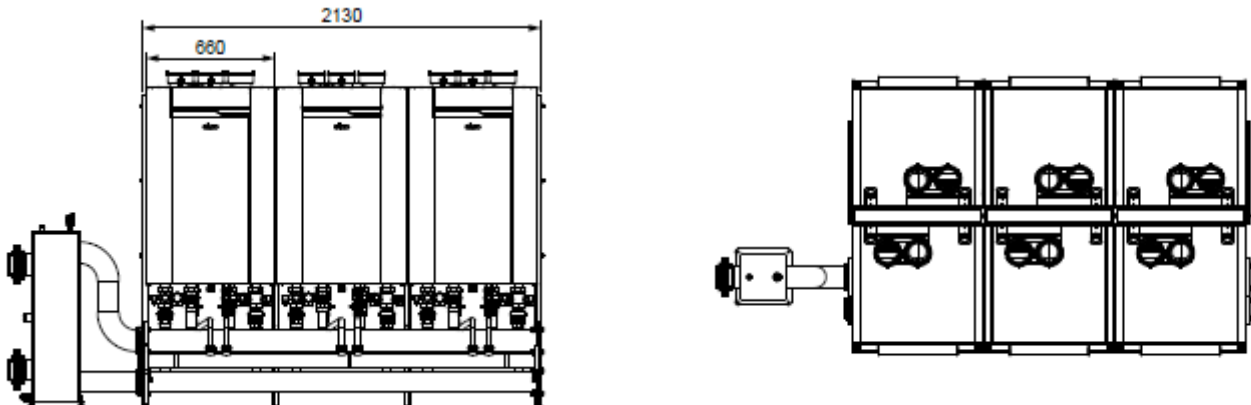

THISION L PLUS 8 boilers free-standing back-to-back

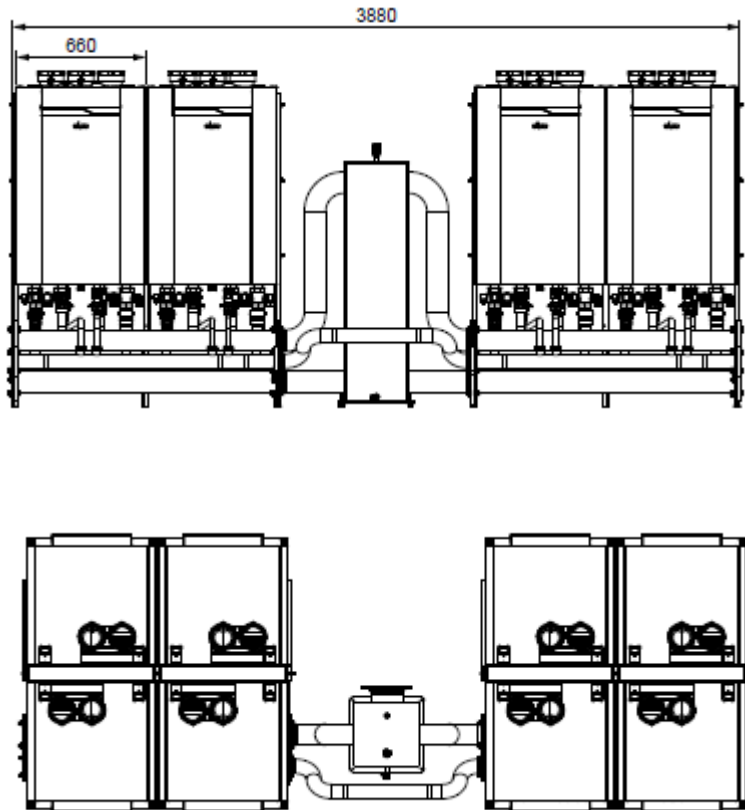

Technical description

Clearances

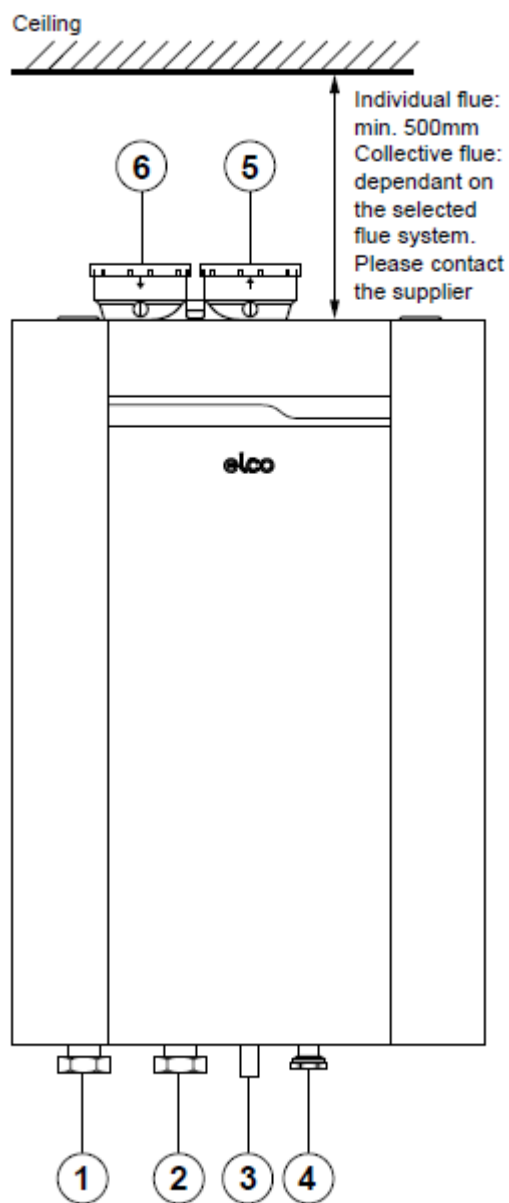
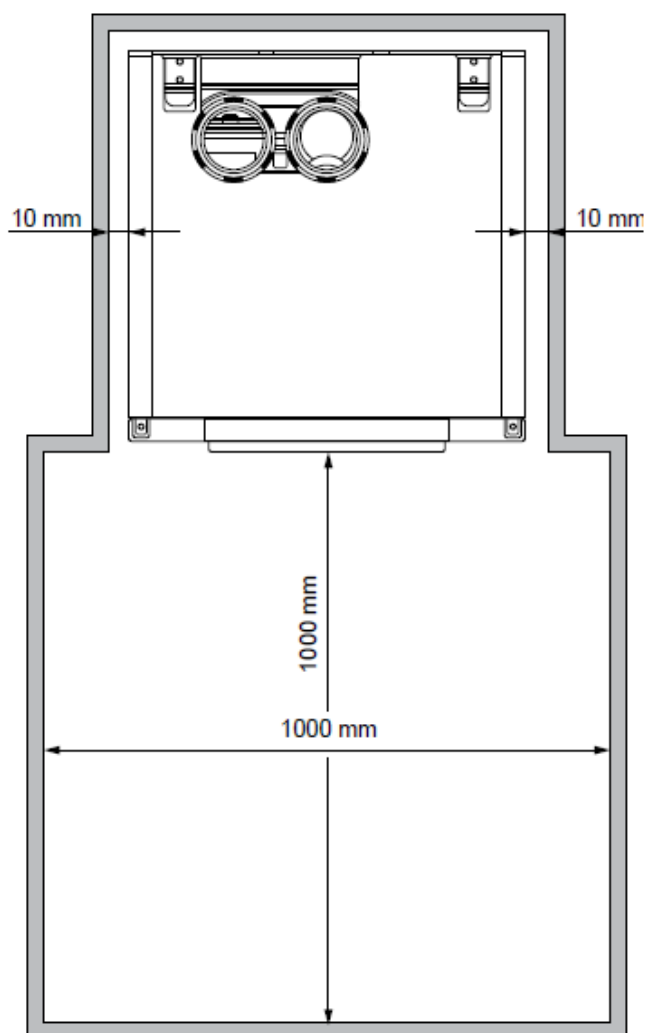

Pay attention to the minimum distance required between the boilers, walls and ceiling for installing and removing the housing.

If you have opted to build the hydraulic part yourself, then ELCO recommends using "Connection set THISION L PLUS as single boiler" for each boiler.

1. Boiler return connection
2. Boiler flow connection
3. Condensate drain
4. Gas
5. Flue gas outlet
6. Air supply

Technical description

Declaration of conformity

Declaration of Conformity

We, ELCO GmbH, Hohenzollenstrasse31, D-72379 Hechingen
declare under our responsibility that the product

THISION L PLUS

Is in conformity with the following standards:

EN 15502-1
EN 15502-2-1
EN 55014-1 / -2
EN 61000-3-2 /-3
EN 60 335-1/ -2

And in accordance with the guidelines of directives:

92 / 42 / EEC (boiler efficiency directive)
2009 / 142 / EEC (gas appliance directive)
2014 / 35 / EU (low voltage directive)
2014 / 30 / EU (EMC directive)
2009 / 125 / CE Energy related Products
811-813-814 / 2013 EU regulation

This product is designated with CE number:

CE-0063CM3648

Norm and regulations

General regulations Application Norms and regulation

General regulations

This document contains important information with regard to safety and reliability of the installation, its commissioning and the operation of the THISION L PLUS boiler. All described activities must be carried out exclusively by authorized technicians. Only OEM parts of the boiler manufacturer may be used; in contrary cases, our warranty and guarantee provisions are excluded.

Intended use

The THISION L PLUS is a condensing and modulating gas boiler, which is suspended from walls and is delivered with a pre-mix burner. The maximum target temperature of the boiler is 90°C.

Standards and regulations

All applicable standards (both European and national) must be observed during the installation and operation of the THISION L PLUS boiler, including:

- Local building regulations, with regard to the installation of heating facilities and waste gas exhaust systems;
- Regulations about a connection to the electrical utility network (mains);
- Regulations of the local gas utility;
- Standards and regulations concerning safety facilities for heating systems;
- Additional local laws/regulations, which are applicable to the installation and operation of heating systems.
- See the chapter "Commissioning", for those regulations applicable to heating water and warm water quality.

CE-certified and conforms to the following European directives and standards:

- 92 / 42 / EEC

Efficiency of hot water heating systems

- 2016 / 426 / EU

Gas appliance regulation

- 2014 / 35 / EU

Low voltage directive

- 2014 / 30 / EU

EMC directive

- EN 15502-1

Requirements for gas-fired systems

– Part 1: General requirements and tests

- EN 15502-2

Requirements for gas-fired systems

– Part 2-1: Type C such as B2, B3 and B5 with nominal calorific debit =< 1000 kW

- EN 55014-1 (2011) EMC – Requirements for household appliances, electrical tools and similar equipment – Part 1: Emissions

- EN 55014-2 (2008) EMC – Requirements for household appliances, electrical tools and similar equipment – Part 2: Safety—product family standard

- EN 61000-3-2 (2013)

Electromagnetic compatibility (EMC) - Part 3-2: Framework conditions - framework conditions for current fluctuations (current drain 16 A per phase)

- EN 61000-3-3 (2014)

Electromagnetic compatibility (EMC) - Part 3-3: Framework conditions for voltage fluctuations, voltage loss and flicker in public low-voltage networks, for equipment with a nominal 16 A current per phase, which are not subject to any special connection regulations.

- EN 60335-1 (2011) Household and similar electrical equipment

- Safety - Part 1: General requirements

- EN 60335-2-102 (2006/A1-2010)

Household and similar electrical equipment - Safety - Part 1: Special requirements for gas, oil and solid fuel-fired equipment with electrical connections.

It is necessary that the currently valid local normatives will be observed.

UK:

British Standards

- BS 5440 - BS 6644 - BS 6891 BS 7074 - BS 8552 - BS EN 60335 Pt1 - BS EN 12828

IGEM Documents

- IGE/UP/1&1A - IGE/UP/2 -

IGE/UP/10

UK Regulation

- Clean Air Act 1993

- IEE Regulations

- Building Regulations

- Gas Safety (Installation & Use) Reg.

Other Guidance

- ICOM - BSRIA Documents

BG29/2012

- BG50/2013 - CIBSE Guides

(B1, C, F)

- HSE - INDG 436

Germany:

- RAL - UZ 61 / DIN 4702-8

- EnEV -Energieeinsparverordnung

- TRGI (DVGW G600) - Technical Guideline for gas installations

- ATV DVWK-A251 - Condensate drain in sewage system

- TRF - Technical Guideline for propane gas

- DVGW

Norm and regulations

General regulations Application Norms and regulation

Switzerland:

- SVGW
- Regulations of the cantonal authorities (eg fire brigade regulations)
- Gebäude Klima Schweiz
- EKAS - Form, 1942: Guidelines propane gas, Part 2
- BAFU - Federal Office for the Environment
- SWKI - Swiss Association of Building Technology Engineers

Austria:

- ÖNORM H 5152
- ÖNORM M 7443 Part 1, 3, 5, 7
- ÖNORM M 7457
- ÖNORM H 5195-1
- ÖVGW - Guideline G1, G2, G41, G4
- die örtlichen Bauordnungen und Vorschriften sind zu beachten.



Incorrect operation can cause damage to the boiler and system components and has the potential to introduce hazards. Only persons with appropriate knowledge and qualifications, should be allowed to make adjustments to the boiler and associated equipment.



It must be ensured that children cannot play with the equipment.



The equipment may not be used by children, by persons with a hindrance of bodily, mental or sensory capacities, or with insufficient experience and knowhow, unless they are supervised or have received corresponding instructions.

Norm and regulations

Water and hydraulic system

Heating water quality

Fill the installation with drinking water.

In most cases, a central heating installation can be filled with water according to the nationally valid regulations, whereby a treatment of the water is not necessary. To avoid problems, the quality of the filling water must conform to the requirements in Table 1. If the filling water should not conform to these requirements, then it is recommended to treat the water correspondingly (see VDI2035). Warranty claims become invalid if the system has not been flushed during installation, or if the filling water quality does not conform to the ELCO requirements (see Table 1).

For situations that require clarification, please consult Elco Heating Solutions. Failure to comply with manufacturers instruction, may have an affect on terms of warranty.

Installation:

- The use of groundwater, demineralized water and distilled water, is not permitted (an explanation of these terms can be found on the next page).

- If the drinking water quality lies within the limits of the values in Table 1, then one can proceed with the installation of the system and the flushing of the equipment.

- Residues of corrosion products (magnetite), assembly materials, cutting oil and other undesirable products, must be removed during the flushing operation.

- Another possibility for removing dirt is the use of a filter. The filter type must conform to the system specific requirements and the type of contamination. ELCO recommends the use of a filter. In such a case, one should make sure to take the entire piping system into consideration.

- The central heating installation must be de-aerated properly, before it is put into operation. Please review the Chapter "Commissioning" in this regard.

- If a regular topping up of water is required (> 5% per year), then there is a problem with the system that must be rectified by a certified technician. Regular topping up with fresh water and oxygen adds lime to the system, which leads to deposits.

- If an anti-frost agent or other additives are used, then it must be regularly checked to ensure that the filling water quality conforms to the manufacturer requirements.

- Inhibitors may only be used after consultation with ELCO.

- The use of such agents must be protocolled.

Floor heating

When a floor heating system is connected that uses plastic pipes, it must be ensured that it conforms to the standard DIN 4726-4729. If the system does not fulfil the standard, then a system separation must be applied.

If the regulations with regard to plastic piping are not observed, then warranty claims become null and void (see the warranty conditions).

Parameters	Value
Water type	Drinking water Softened water
pH	6.0 - 8.5
Conductivity (at in µS/cm)	Max. 2500
Iron (ppm)	Max. 0.2
Hardness (°dH / °fH)	
Installation volume/performance <20 l/kW	1- 12
Installation volume/performance ≥20 l/kW	1- 7
Oxygen	Oxygen diffusion is not permitted during operations. Max. 5% of the system volumes may be topped up annually.
Corrosion inhibitors	See the Chapter "System water additives"
pH raising or lowering agents	See the Chapter "System water additives"
Anti-frost additives	See the Chapter "System water additives"
Other chemical additives	See the Chapter "System water additives"
Solid substances	Not permitted
Residues in the heating water, which are not a component of the drinking water are	Not permitted

Norm and regulations

System water additives

DHW quality

The system water additives, which are listed in the table, have been released by the manufacturer and take into consideration the indicated dosage quantities.

In case of incorrect use, and if the maximum concentration quantities are exceeded, then the guarantee for all components that come in contact with heating water are null and void.

Additive type	Supplier and specifications	Max. Concentration	Application
Corrosion inhibitors	Sentinel X100 Corrosion resistant protection agent of CH systems Kiwa certified	1-2 l/100 litres CH water content	Aqueous solution of organic and inorganic agents preventing corrosion and scale forming
	Fernox F1 Protector Corrosion resistant protection agent of CH systems Kiwa certified KIWA-ATA K62581, Belgaqua certified Cat III	500 ml can or 265 ml Express / 100 litres CH water content	Preventing corrosion and scale forming
Anti-freeze	Kalsbeek Monopropyleneglycol / propane-1,2-diol + inhibitors AKWA-Colpro KIWA-ATA Nr. 2104/1	50% w/w	Anti-freeze
	Tyfochor L Monopropyleneglycol / propane-1,2-diol + inhibitors	50% w/w	Anti-freeze
	Sentinel X500 Monopropyleneglycol + inhibitors Kiwa certified	20-50% w/w	Anti-freeze
	Fernox Alphi 11 Monopropyleneglycol + inhibitors Kiwa certified KIWA-ATA K62581, Belgaqua certified Cat III	25-50% w/w	Anti-freeze in combination with F1 Protector
System cleaners	Sentinel X300 Solution of phosphate, organic heterocyclic compounds, polymers and organic bases Kiwa certified	1 litre / 100 litres	For new CH installations Removes oils/grease and flow control agents
	Sentinel X400 Solution of synthetic organic polymers	1-2 litres / 100 litres	For cleaning existing CH installations Removes sediments.
	Sentinel X800 Jetflo Aqueous emulsion of dispersants, moistening agents and inhibitors	1-2 litres / 100 litres	For cleaning new and existing CH-installations Removes iron and lime-related sediments.
	Fernox F3 Cleaner Liquid pH neutral universal cleaner for pre-commissioning new systems	500 ml / 100 litres	For cleaning new and existing CH-installations Removes sludge, limescale and other debris.
	Fernox F5 Cleaner, Express pH neutral universal cleaner concentrate for pre-commissioning new systems	295 / 100 litres	For cleaning new and existing CH-installations Removes sludge, limescale and other debris.

Definition of water types**Drinking water**

Tap water, in conformity with the European Drinking Water Directive: 98/83/EC, dated 3 November 1998.

Distilled water

Water, in which no more salts are present.

Softened water

Water, from which calcium and magnesium ions have been partially removed.

Demineralized water

Water, from which almost all salts have been removed (very low conductivity).

Flue gas system

Requirements and regulations

Materials

Flue gas data

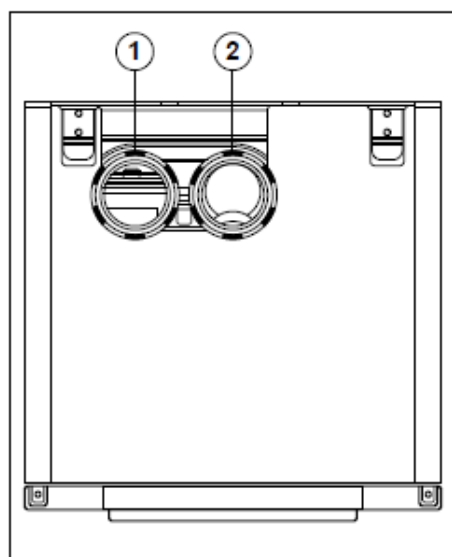
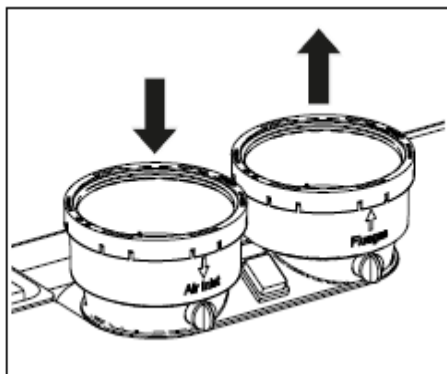

Parallel boiler connection

The boiler comes as standard with a parallel connection for the flue gas outlet and air supply system. For the air supply opening (1) diameter and the flue gas outlet connection (2), see table below.

The air supply channel can be connected to it, or, if it involves an "open device" (Drainage category B), an air filter is recommended.

Flue gas connection

We recommend the use of ELCO's comprehensive range of flue gas components.

For further information, please see the installation instructions:

- ELCO wall terminals
- ELCO roof terminals
- ELCO flue pipe components, both individual pipes and concentric tubes.

Regulations about the construction and installation of flue gas systems are different from country to country. It must be ensured that all national regulations with regard to chimney systems are observed.

It is not necessary to install a separate condensate drain for the flue gas system, since the condensate will be flushed out via the boiler and into the siphon. Please observe the following recommendations:

- Only use corrosion-resistant material
- The diameter must be calculated and selected according to the national regulations.
- The length of the flue gas system must be kept as short as possible (and must not exceed the maximum permitted length, see the documentation for planners)
- Horizontal flue gas tubes must have an inclination of at least 3° back towards the boiler.

Air supply connection

If required, a separate room sealed air supply tube may be connected via the inclusion of the optional air supply connector fitting. The diameter must be calculated in conformity with national regulations and in combination with the flue gas system. The overall resistance of the air supply and flue gas tubes may not exceed the maximum supply pressure of the fan at any time. (Also see the Chapter "Technical data")

Concentric boiler connection

The boilers 60-70-100-120-140 can be converted into a concentric connection using the parallel/concentric adapter 100/150 (optional) and carrying out the following tasks:

- Open and remove the frontal panel and the top panel.
- Lift the parallel connection.
- Disconnect the main switch 230V connection and remove it.
- Replace the parallel connection with parallel concentric adapter.
- Connect and fit the main switch 230V according to previous configuration.

The THISION L PLUS-boilers can be used both in an "open" and in "closed" system.

Open system

The required combustion air is taken from the immediate environment (boiler room). For this purpose, please comply with the applicable boiler room ventilation regulations.

When using boiler category B23 and B33 as an 'open boiler', the protection degree of the boiler will be IPX0D instead of IPX4D.

An air filter or a grid is recommended on the air intake of the boiler (available as an additional component)

Closed system

The required combustion air is drawn in from the outside through a channel. This improves installation possibilities within a building. In general, outside air is cleaner than air from the boiler room.

Flue gas system Connections

Air-/ flue gas ducts– installation variants for individual boilers

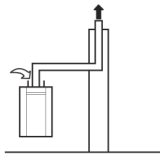
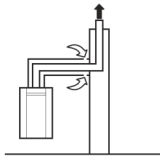
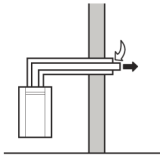
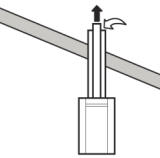
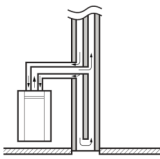
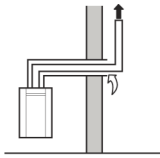
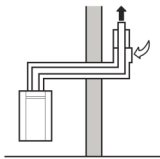
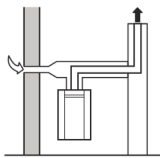
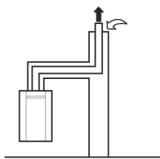
Ambient combustion air		
B23	Flue gas duct into the chimney, aspiration of air from the surroundings. End section of the flue gas duct above the roof.	
B33	Flue gas duct into the chimney, aspiration of air from the surroundings. End section of the flue gas duct above the roof.	
Combustion air taken from outside		
C13	Flue gas duct and suction air over the outer wall, must be in the same square area.	
C33	The flue gas and suction air ducts via the roof terminal, must be in the same square area.	
C43	Suction air and flue gas duct via the chimney system, which is integrated in the building.	
C53	Section the air and flue gas exhaust to the outside, in areas with different pressures. Vertical end section of the flue gas duct.	
C63	Specially developed equipment, for connection to certified air-flue gas systems that operate separately from one another.	
C83	Specially developed equipment, for connection to certified air-flue gas systems that operate separately from one another.	
C93	Air and flue gas piping to the flue gas chimney, via installation in the roof and in a humidity-resistant flue gas chimney.	

Flue gas system

Connections

Air-/ flue gas ducts– installation variants for individual boilers

Opting for a collective flue gas outlet is determined by:

- The position of the boilers with regard to their outlet area
- Sufficient space above the boilers
- Large number of boilers

You may opt for:

- Collective flue gas outlet under-pressure
- Collective flue gas outlet over-pressure

In many situations, flue gases cannot be vented individually because the installation is indoors. For such situations, we recommend collective venting by means of under-pressure or over-pressure using a flue gas outlet system. The air supply may also be supplied collectively, but if the boiler room is suitable for that purpose for that purpose it may also be obtained from this area ('open device' Boiler category B).

If you install a common duct providing combustion air to more than one appliance, there is a risk that combustion air would be drawn from an adjacent appliance.

This may then be subject to a negative pressure.

In case of collective venting of flue gases, the flue gas-venting outlet always has to end up in the open area (outlet area 1) according to Country specific regulations.

ELCO can supply a collective flue gas outlet system for the ELCO THISION L PLUS. Refer to the following chapters with regard to the various possibilities and maximum pipe lengths than can be used.

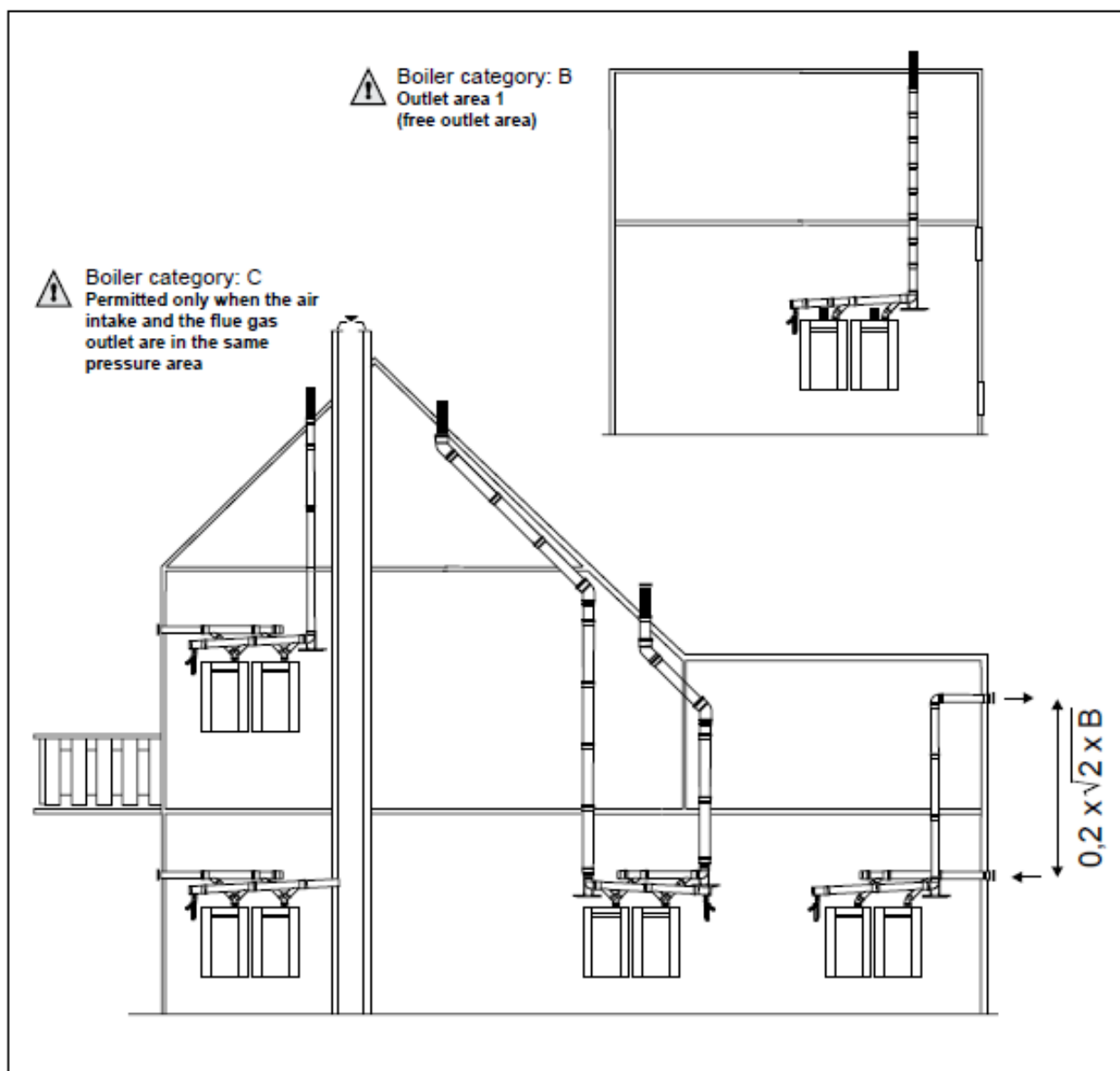

Flue gas system

Requirements and regulations

Materials

Flue gas data

Notes

The tables below give guidance on the maximum lengths of air and flue gas tubes that may be connected. If a room sealed installation is being made utilising separate air and flue gas tubes, the lengths of both tubes must be added together and not exceed the relevant value given in the tables.

The radius of any bend used in the flue gas system must not exceed 87.5°.

Walls that are sensitive to heat should be insulated.

Construct the flue system in such way that no recirculation may take place.

When the boiler is operational, it produces a white plume of condensation. This condensation plume is harmless but may cause some inconvenience, particularly in the case of wall terminal. As a result, roof terminals are preferred. In a closed installation, roof terminals should be at the same height preventing flue gas from being sucked in by the other boiler (recirculation). Outlets in recesses and near erected walls may also bring about flue gas recirculation. Recirculation has to be prevented at all times.

For installation in UK please refer to installation guidance in BS6644 and IGE UP10.

Dimensioning (reference value)

	Tube size	Maximum length in metres (roof terminal not included)			
Changes of direction		0	2	3	4
60	Ø100 mm	82	78	76	74
70		60	56	54	52
100		34	30	28	26
120		17	13	11	9
140		16	12	10	8
170	Ø130 mm	35	30	27	25
200		30	25	22	20

	Tube size	Maximum length in metres (roof terminal included)			
Changes of direction		0	2	3	4
60	Ø100/150 mm	14	11	9	8
70		14	11	9	8
100		12	9	7	6
120		8	5	3	2
140		9	6	5	3

Required minimum (flue enclosure) shaft cross-section		
Diameter flue duct	Square shafts	Round shafts
100 mm	140 x 140 mm	160 mm

Flue gas system

Requirements and regulations

Materials

Flue gas data

Notes

The tables below give guidance on the maximum lengths of air and flue gas tubes that may be connected. If a room sealed installation is being made utilising separate air and flue gas tubes, the lengths of both tubes must be added together and not exceed the relevant value given in the tables.

The maximum length of any external section of flue pipe must not exceed 5m.

The radius of any bend used in the flue gas system must not exceed 87.5°.

Walls that are sensitive to heat should be insulated.

Construct the flue system in such way that no recirculation may take place.

When the boiler is operational, it produces a white plume of condensation. This condensation plume is harmless but may cause some inconvenience, particularly in the case of wall terminal. As a result, roof terminals are preferred. In a closed installation, roof terminals should be at the same height preventing flue gas from being sucked in by the other boiler (recirculation). Outlets in recesses and near erected walls may also bring about flue gas recirculation. Recirculation has to be prevented at all times.

For installation in UK please refer to installation guidance in BS6644 and IGE UP10.

Dimensioning (reference value)

	Tube size	Maximum length in metres (roof terminal not included)			
Changes of direction		0	2	3	4
60	Ø100 mm	82	78	76	74
70		60	56	54	52
100		34	30	28	26
120		17	13	11	9
140		16	12	10	8
170	Ø130 mm	35	30	27	25
200		30	25	22	20
	Tube size	Maximum length in metres (roof terminal included)			
Changes of direction		0	2	3	4
60	Ø100/150 mm	14	11	9	8
70		14	11	9	8
100		12	9	7	6
120		8	5	3	2
140		9	6	5	3

Required minimum (flue enclosure) shaft cross-section		
Diameter flue duct	Square shafts	Round shafts
100 mm	140 x 140 mm	160 mm

Flue gas system

Collective flue gas outlet underpressure

Diameter and venting lengths of the flue gas outlet/air supply:

Open system, with underpressure (calculated with thermal draft) under atmospheric circumstances.

NOTE!

1. IPX0D at flue category B23 and B33

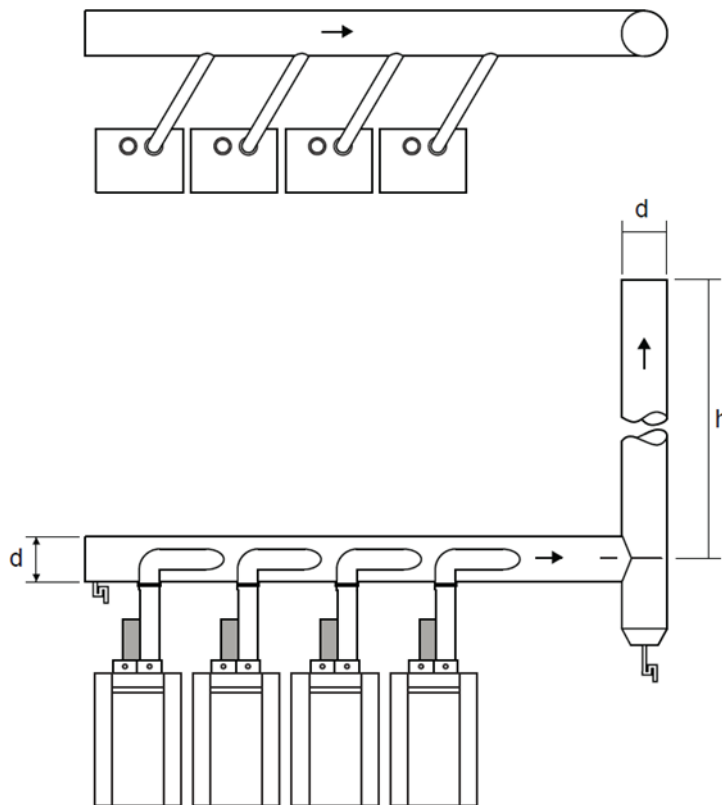

Open system, underpressure				
Output (80/60) [kW]	d = minimum diameter Ø in mm			
	h = 2 - 5	h = 5 - 9	h = 9 - 13	h = 13 - 17
114 - 240	210	200	190	190
240 - 360	300	270	260	250
360 - 480	360	330	310	300
480 - 600	440	380	360	340
600 - 720	470	420	400	380
720 - 840	550	470	430	410
840 - 960	600	510	470	440

Flue gas system

Collective flue gas outlet underpressure

Diameter and venting lengths of the flue gas outlet/air supply:

Closed system, with under-pressure (calculated with thermal draft) under atmospheric circumstances.

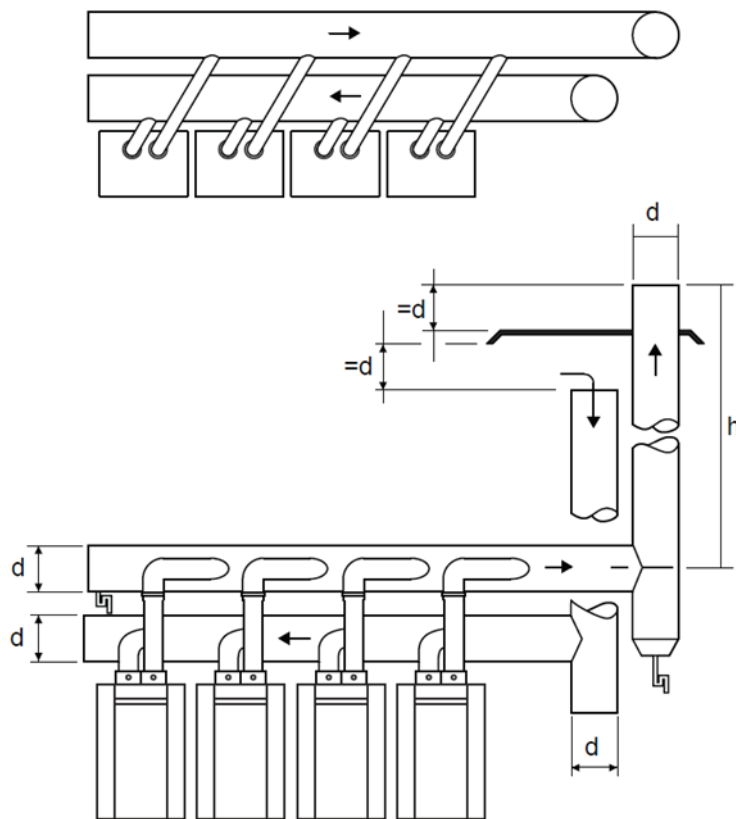

Closed system, underpressure, parallel				
Output (80/60)	d = minimum diameter Ø in mm			
[kW]	h = 2 - 5	h = 5 - 9	h = 9 - 13	h = 13 - 17
114 - 240	240	220	220	220
240 - 360	330	300	290	270
360 - 480	390	370	350	330
480 - 600	460	410	390	380
600 - 720	500	460	440	420
720 - 840	550	500	470	460
840 - 960	600	540	510	490

Flue gas system

Collective flue gas outlet overpressure

An installation with a collective flue gas outlet over-pressure in combination with individually controlled boilers (e.g. 0-10VDC control), where no bus cable is connected, is **NOT** allowed.

Diameter and venting lengths of the flue gas outlet/air supply:

Open system with over-pressure.

NOTE!

1. IPX0D at flue category B23 and B33
2. Only with bus cable connected!
3. Adjust parameter 102 to 2

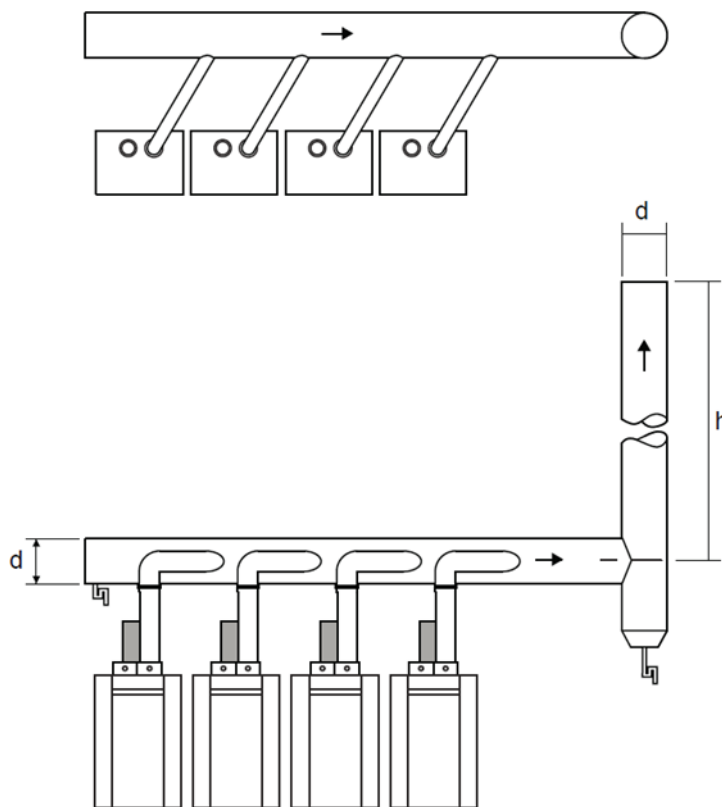

Open system, overpressure				
Output (80/60)	d = minimum diameter Ø in mm			
[kW]	h = 2 - 5	h = 6 - 10	h = 11 - 15	h = 16 - 20
114 - 240	150	150	150	150
240 - 360	150	150	180	180
360 - 480	180	180	180	200
480 - 600	200	200	220	220
600 - 720	230	230	250	250
720 - 840	260	260	260	260
840 - 960	280	280	280	300
960 - 1200	280	280	280	300

Flue gas system

Connections

Collective flue gas outlet overpressure

Diameter and venting lengths of the flue gas outlet/air supply:

Closed system with over-pressure.

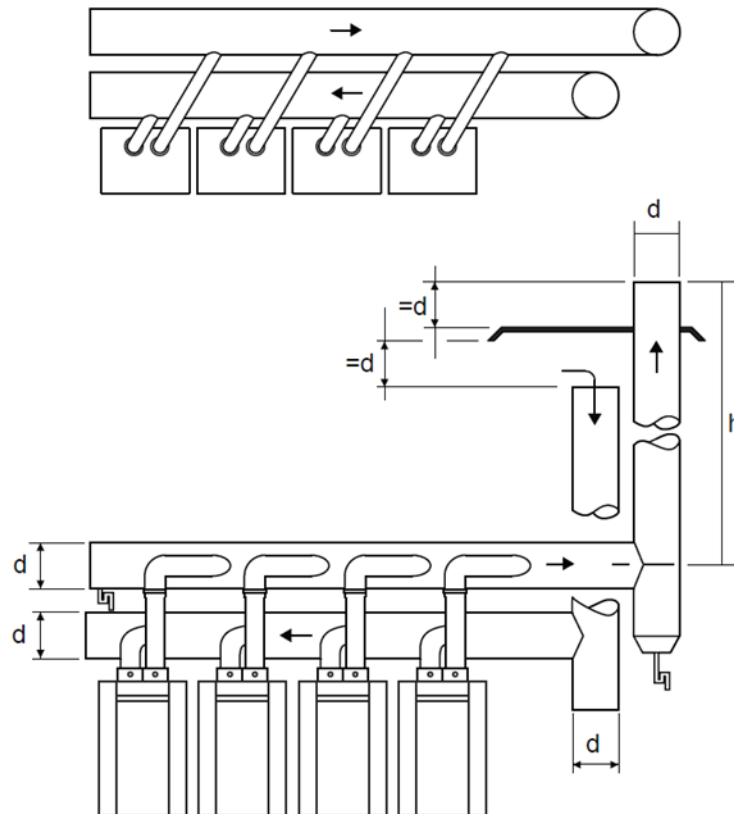

Closed system, overpressure, parallel				
Output (80/60)	d = minimum diameter Ø in mm			
[kW]	h = 2 - 5	h = 6 - 10	h = 11 - 15	h = 16 - 20
114 – 285	150	150	150	150
285 - 524	150	200	200	200
524 - 1440	180	300	300	300

Boiler Installation

Electrical connection

Electrical connections must be carried out by an authorized electrical technician, and in conformity with valid national and local standards and regulations. A dedicated mains switch must be used for the power supply, with at least 3 mm contact openings. It must be mounted inside of the boiler room. The mains switch is used for switching off the power supply during maintenance works.

All cables are passed through the cable guide at the top of the boiler, and are led to the electronics panel at the front of the boiler.

The electric diagram must be observed during all electrical connection works (see the following pages).

A 230V -50Hz mains electrical supply is required fused externally at 5A.

A deviation on the grid of 230V (+10% or -15%) and 50Hz

The following additional regulations also apply:

- The boiler's wiring is not allowed to be changed;
- All connections have to be made to the terminal block.

Installation of outdoor sensor

If an outdoor sensor is connected to the boiler, then the sensor must be positioned in conformity with the adjacent drawing.

If an outdoor sensor is NOT connected please refer to PADIN configuration in External control.

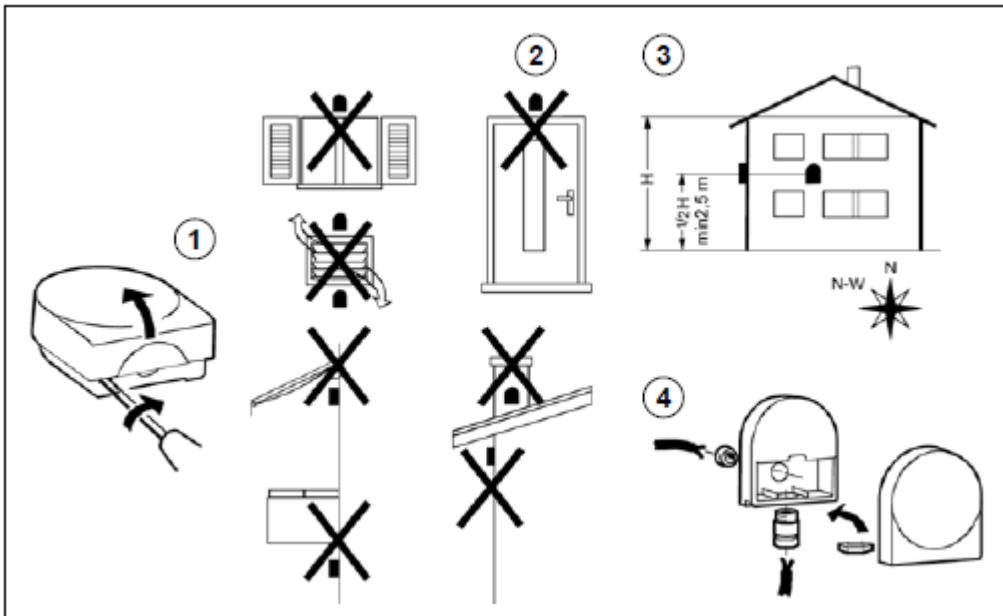

Boiler Installation

Electrical connection

The boiler has 4 socket blocks for all electrical connections:

1. High voltage supply (230V)
2. Voltage free switches (230V relays)



Caution:

After removing the panels 230V parts can be reached.

Electrical connections are only to be carried out by qualified person.

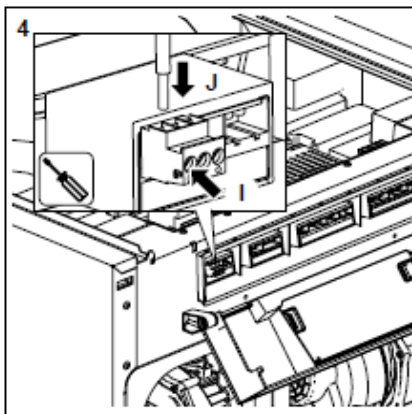
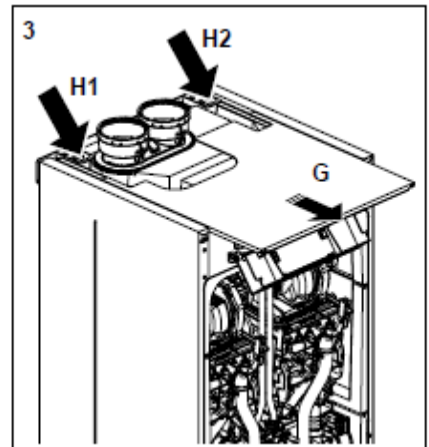
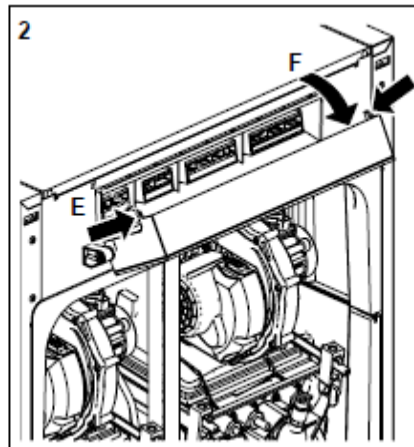
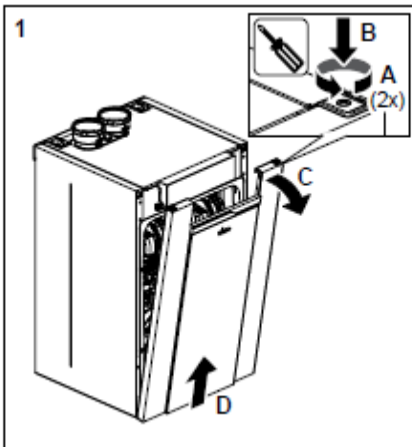
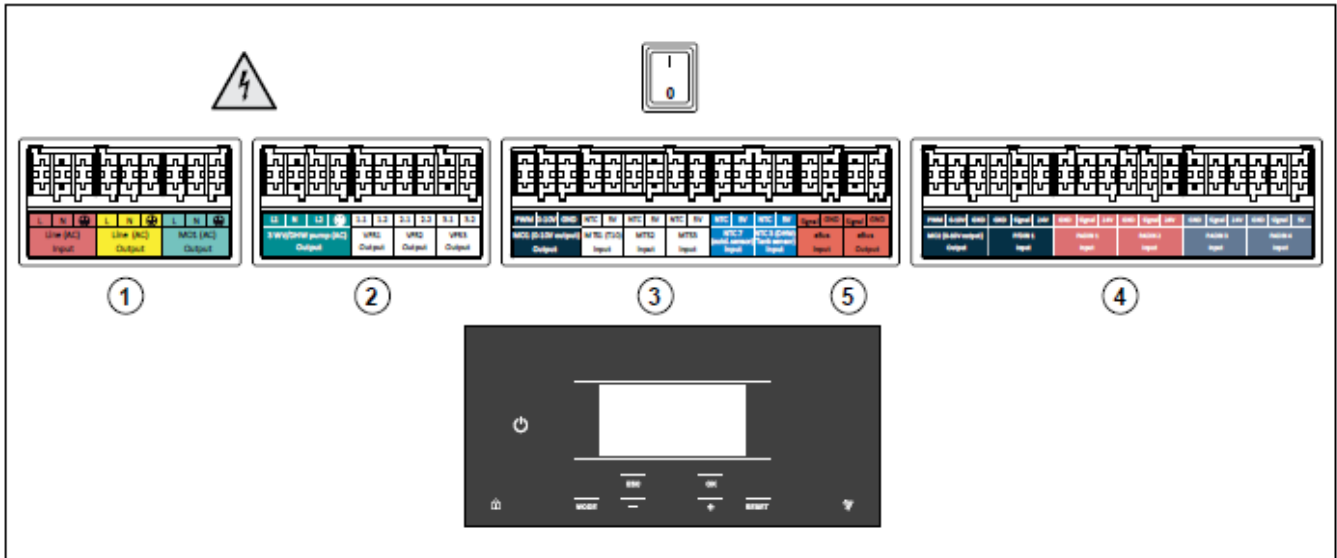

Electrical connections above can be reached following the steps below:

1. Remove the front panel.
2. Press both external sides of the control unit HMI (E) and rotate the display (F).
3. Slide the top panel to the front and use the entrance at the back of the boiler to insert the cables (H1 for high voltage cable, H2 for low voltage cable).
4. Connect the cable with screw connectors already in the socket blocks.

Boiler Installation

Electrical connection

1

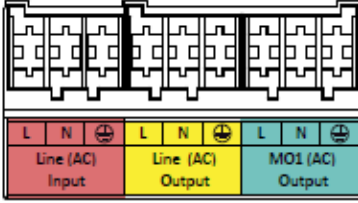

Contact	Line Type	Name	Function Description	Electrical Description
1	Line	Main input	The Main Power supply to the boiler	230V (+10%; -15%) @50Hz
2	Neutral			
3	Earth			
4	Line	Main Output	Output of the main power input, Live when the switch of the boiler is on	Same as Input
5	Neutral			
6	Earth			
7	Line	MO1 System pump	will run with the boiler pump of the master	230/120VAC; 1A max (80A inrush max); Live switched
8	Neutral			
9	Earth			

2

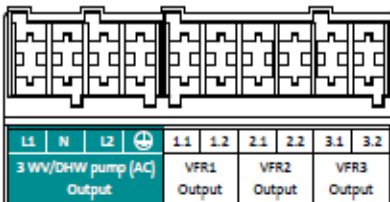

Contact	Line Type	Name	Function Description	Electrical Description
1	Line	3 way Valve	Active CH	230/120 VAC; 1A max Fused
2	Neutral	3 way Valve/P2		
3	Line	P2 / 3 way valve	Active for DHW	230/120 VAC; 1A max 80A inrush max fused
4	Earth	Protective Earth		
5	1.1	Voltage Free Contact 1	a.i. HC1 pump	230VAC 2A max 80A inrush max not fused
6	1.2			
7	2.1	Voltage Free Contact 2	a.i. Alarm Output	230VAC 1A max (cos phi > 0.8) not fused
8	2.2			
9	3.1	Voltage Free Contact 2	a.i. Lpg shutoff valve	230VAC 1A max (cos phi > 0.8) not fused
10	3.2			

Boiler Installation

Electrical connection

3 & 5

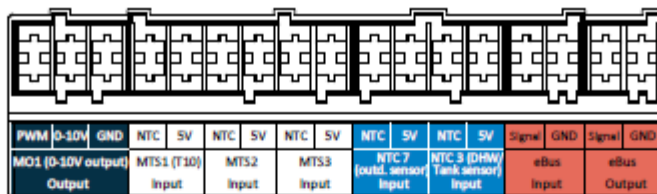

Contact	Line Type	Name	Function Description	Electrical Description
1	PWM	Multifunctional Output 1	DHW pump modulator System Pump Modulator Tank Filling pump Modulator 0..10 Volt feedback to BMS	PWM: 0,1÷4 kHz; Vhigh= 12V; Vlow≤ 0,7V; Ihigh ≤ 10 mA 0..10 Volt
2	0-10 Volt			
3	GND			
4	NTC input	Multifunctional Temperature Input 1	T10	NTC 10k β=3977
5	5 Volt			
6	NTC input	PMultifunctional Temperature Input 2	i.a. Buffer tank top/bottom DHW circulation sensor*	NTC 10k β=3977
7	5 Volt			
8	NTC input	Multifunctional Temperature Input 3	i.a. Buffer tank top/bottom DHW charging sensor*	NTC 10k β=3977
9	5 Volt			
10	NTC input	Outdoor sensor (T4)	Dedicated temperture sensor for outdoor	NTC 1k β=3977
11	5 Volt			
12	NTC input	Tank Sensor (T3)	Dedicated temperture for DHW temperature	NTC 10k β=3977
13	5 Volt			
14	Signal	eBus2	Communication bus for i.a. cascade communication / thermostat / clib-in	
15	GND			
16	Signal	eBus2	Communication bus for i.a. thermostat / clib-in	
17	GND			

4

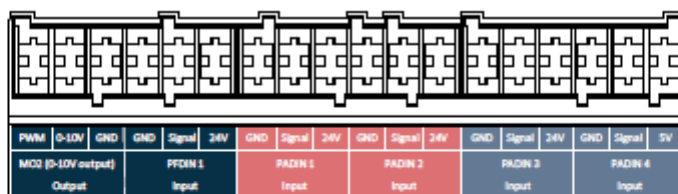

Contact	Line Type	Name	Function Description	Electrical Description
1	PWM	Multifunctional Output 2	System Pump Modulator Tank Filling pump Modulator 0..10 Volt feedback to BMS*	PWM: 0,1÷4 kHz; Vhigh= 12V; Vlow≤ 0,7V; Ihigh ≤ 10 mA 0..10 Volt
2	0-10 Volt			
3	GND			
4	GND	Programmable Frequency Digital Input	DHW Flow meter or on/off signal	GND Digital: close with +24Vdc; Frequency 0÷24V; max 400 Hz Power supply: +24Vdc, 10mA max
5	Signal			
6	24 Volt			
7	GND	Programmable Analog Digital Input 1	i.a. Heat generation lock External consumer request Room Thermostat 1*	GND Digital: close with +24Vdc; Analog: 0÷10V Power supply: +24Vdc, 10mA max
8	Signal			
9	24 Volt			
10	GND	Programmable Analog Digital Input 2	i.a. 0..10 Volt temperture request / power request Room Thermostat 2*	GND Digital: close with +24Vdc; Analog: 0÷10V Power supply: +24Vdc, 10mA max
11	Signal			
12	24 Volt			
13	GND	Programmable Analog Digital Input 3	i.a. Heat generation lock External consumer request Room Thermostat 3*	GND Digital: close with +24Vdc; Analog: 0÷10V Power supply: +24Vdc, 10mA max
14	Signal			
15	24 Volt			
16	GND	Programmable Analog Digital Input 4	i.a. Heat generation lock External consumer request Low water cutoff*	GND Digital: close with +5Vdc; Analog: 0÷5V Power supply: +5Vdc, 10mA max
17	Signal			
18	5 Volt			

Boiler Installation

Electrical connection

MO1 OUTPUT (AC)		
ECU I/O	Menu Evo Code	Setting
MO1	Multi Out HV 24.7.0 (Commercial Boiler); 26..32.7.0 (Commercial Boiler – Slave 1..7);	8-12-6-13

Function	Setting Values
None	0
System Pump	1
HC1 Pump	2
Circulating Pump	3
DHW Intermediate Circuit	4
BUF Filling Pump	5
Storage Tank Transfer Pump	6
Heat Generation Shut off Valve	7
Heat Request	8

VFR 1		
ECU I/O	Menu Evo Code	Setting
VFR 1	Free Contact 1 24.7.1 (Commercial Boiler); 26..32.7.1 (Commercial Boiler – Slave 1..7);	8-12-6-14

Function	Setting Values
None	0
System Pump	1
HC1 Pump	2
Circulating Pump	3
DHW Intermediate Circuit	4
BUF Filling Pump	5
Storage Tank Transfer Pump	6
Heat Generation Shut off Valve	7
Heat Request	8
Alarm Output	9
Flue Gas Damper	10
LPG /Room Supply Fan	11

VFR 2-3		
ECU I/O	Menu Evo Code	Setting
VFR 2	Free Contact 2 24.7.2 (Commercial Boiler); 26..32.7.2 (Commercial Boiler – Slave 1..7);	8-12-6-15
VFR 3	Free Contact 3 24.7.3 (Commercial Boiler); 26..32.7.3 (Commercial Boiler – Slave 1..7);	8-12-6-16

Boiler Installation

Electrical connection

Function	Setting Values
None	0
Heat Generation Shut off Valve	1
Heat Request	2
Alarm Output	3
Flue Gas Damper	4
LPG/ Room Supply Fan	5

MO1 OUTPUT (0-10 V)		
ECU I/O	Menu Evo Code	Setting
MO1_ LV	Multi Out PWM 1 24.7.4 (Commercial Boiler); 26..32.7.4 (Commercial Boiler – Slave 1..7);	8-12-6-17

Function	Setting Values
None	0
System Pump Modulator	1
DHW pump Modulator	2
Circulating Pump Modulator	3
BUF Filling Pump Modulator	4
Boiler Power Feedback	5

MTS 1- 2-3		
ECU I/O	Menu Evo Code	Setting
MTS 1	Multi In Temp 1 24.6.0 (Commercial Boiler); 26..32.6.0 (Commercial Boiler – Slave 1..7);	8-12-6- 4
MTS 2	Multi In Temp 2 24.6.1 (Commercial Boiler); 26..32.6.1 (Commercial Boiler – Slave 1..7);	8-12-6-5
MTS 3	Multi In Temp 3 24.6.2 (Commercial Boiler); 26..32.6.2 (Commercial Boiler – Slave 1..7);	8-12-6-6

Function	Setting Values
None	0
Common Flow Sensor	1
DHW Storage Tank Bottom	2
DHW Circulation Sensor	3
DHW Charging Sensor	4
Buffer Storage Tank Top	5
Buffer Storage Tank Bottom	6
Flue Gas Temperature Sensor	7

Boiler Installation

Electrical connection

MO2 OUTPUT (0-10 V)		
ECU I/O	Menu Evo Code	Setting
MO2_ LV	Multi Out PWM 2 24.7.5 (Commercial Boiler); 26..32.7.5 (Commercial Boiler – Slave 1..7);	8-12-6-18

Function	Setting Values
None	0
System Pump Modulator	1
DHW pump Modulator	2
Circulating Pump Modulator	3
BUF Filling Pump Modulator	4
Boiler Power Feedback	5

PADIN 1- 2-3-4		
ECU I/O	Menu Evo Code	Setting
PADIN 1	Multi In AD 1 24.6.4 (Commercial Boiler); 26..32.6.4 (Commercial Boiler – Slave 1..7);	8-12-6- 7
PADIN 2	Multi In AD 2 24.6.5 (Commercial Boiler); 26..32.6.5 (Commercial Boiler – Slave 1..7);	8-12-6-8
PADIN 3	Multi In AD 3 24.6.6 (Commercial Boiler); 26..32.6.6 (Commercial Boiler – Slave 1..7);	8-12-6-9
PADIN 4	Multi In AD 4 24.6.7 (Commercial Boiler); 26..32.6.7 (Commercial Boiler – Slave 1..7);	8-12-6-9

Function	Setting Values
None	0
Room Thermostat HC1	1
Room Thermostat HC2	2
Room Thermostat HC3	3
0-10 V Input Request	4
External Operating Mode	5
Change over HCs+DHW	
Heat Generation Lock	6
External Consumer Request	7
Flue Gas Damper Feedback	8
Gas Pressure Switch	9

Boiler Installation

Electrical connection

Temperature Sensors

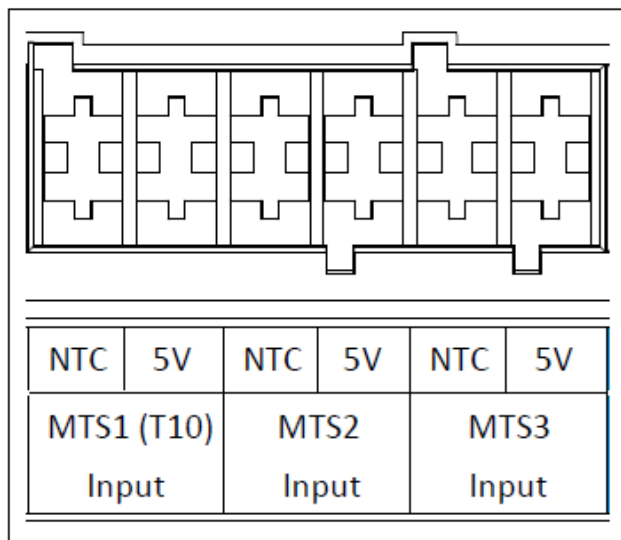

Common Flow Sensor

When a common flow sensor is used (for cascade mandatory) it should be addressed on MTS1.

DHW Tank Setting

There are several schemes for hot water preparations (see pages.....??).

Flue Gas Sensor

Sensors can also be used as flue gas sensor. With a setting for max. Temperature and system has to switch off or a set temperature where system has to reduce the power.

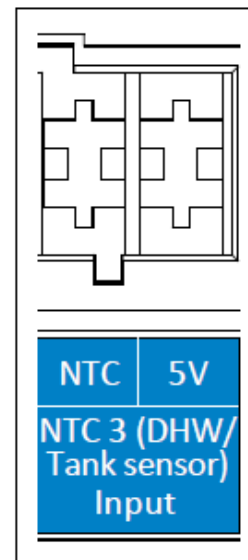
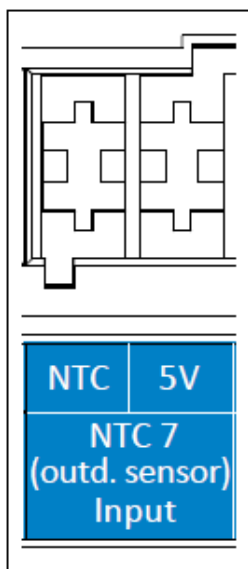

Weather Dependent Regulation

When WDR is used an outdoor sensor is needed. Keep in account this is a 1K sensor.

This control setting has to be selected and is not auto detect.

Basic DHW Preparation

For the basic DHW preparation there is a dedicated tank sensor.

For the other regulations the *tank* sensor is the *top* sensor. Take in account this is a 10K sensor.

Boiler Installation

Electrical connection

External Controls

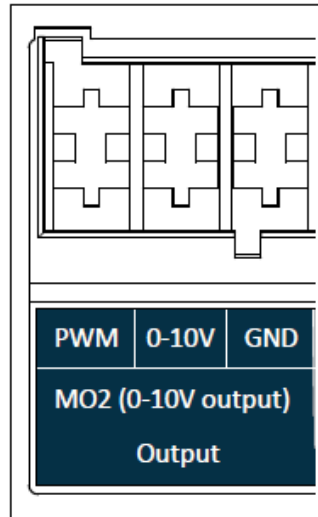
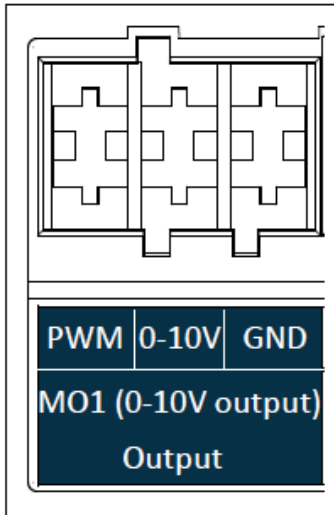

BMS Feedback

For giving feedback to the BMS this output gives a 0-10 Volt signal as indication of load.

Pump Modulation

This output can be set as a controller for several pump types. For types, see scheme on pages (.....??)

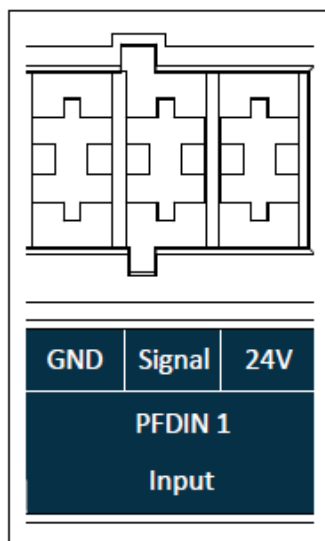

DHW Flow Sensing

For sensing the amount of water flow or set as a flow switch.

Boiler Installation

Electrical connection

External Controls

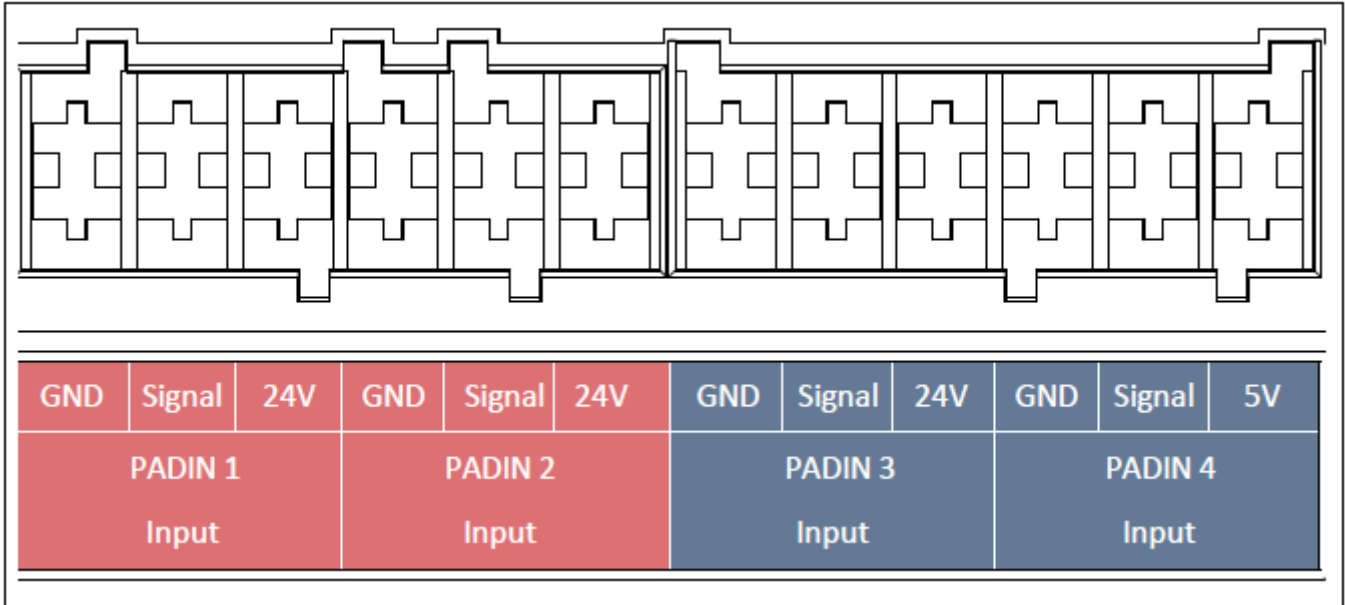

On / Off Heat Request

Input can be used for on/off control up to 3 zones.

HCs+ DHW Changeover

External controller selects if the system can only be active for DHW or for CH and DHW.

Padin 4

Take in account PADIN 4 is 5 volt max. Where 1,2 & 3 are 24 volt.

0– 10 Volt Input

Load and temperature control via an 0-10 volt DC input. When 0-10volt is selected the system can only be controlled with this system.

Heat Generation Lock

As long as the input is open all heat request are blocked.

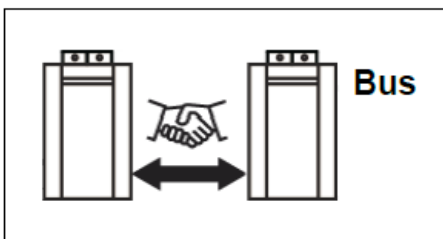

Cascade Connection

The connection between boilers in a cascade is done via eBus2 in and output.

Accessories

To connect accessories like zone Clip-In, solar manager, cube etc. , use the eBus2 connection.

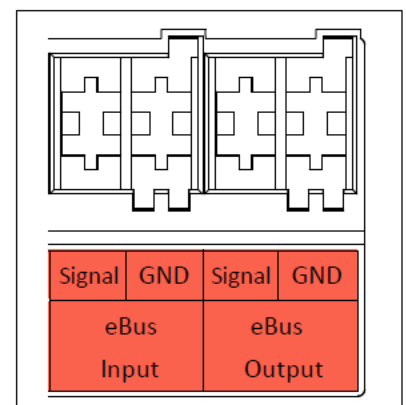

Boiler Installation

Electrical connection

Cascade control

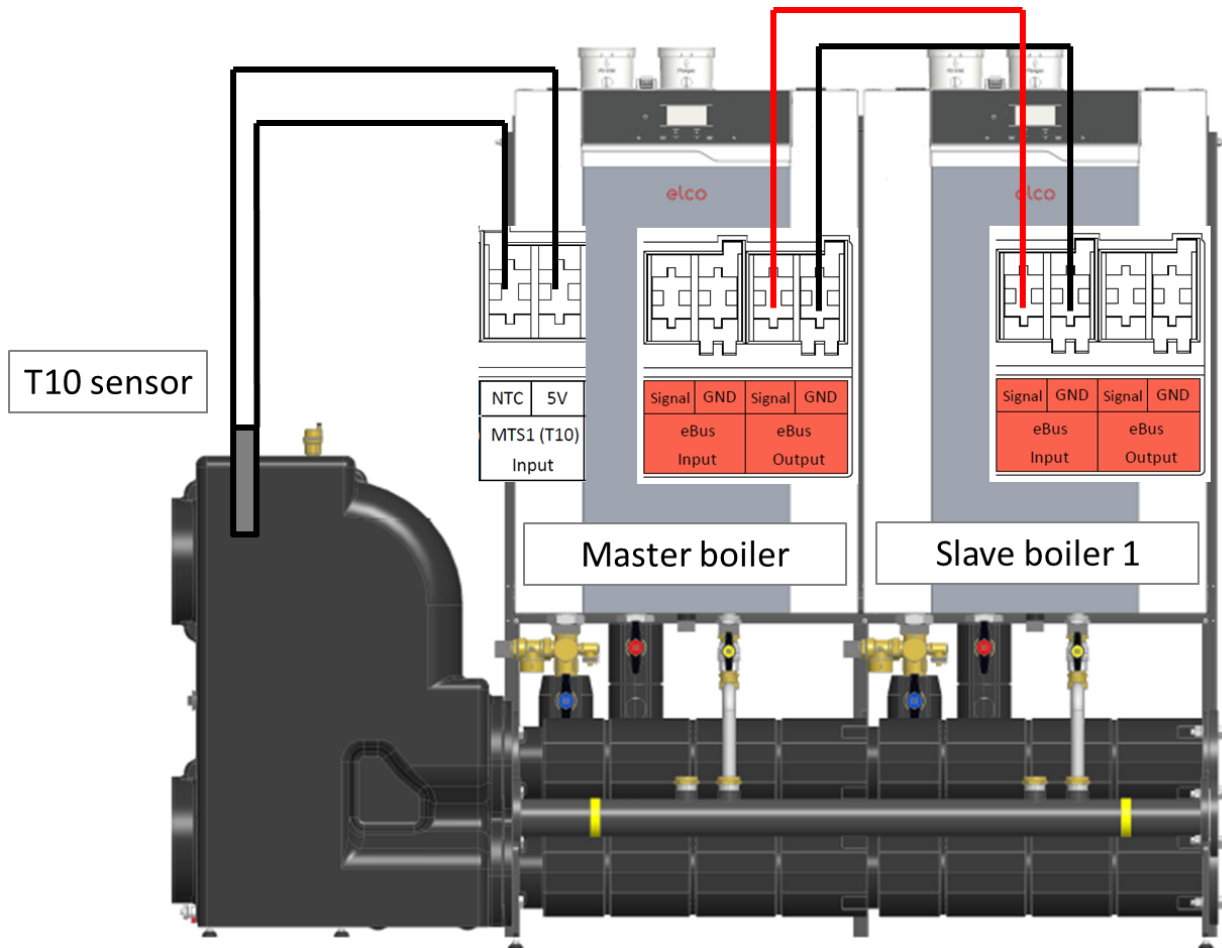

Boiler Installation

Electrical connection

Wiring Diagram

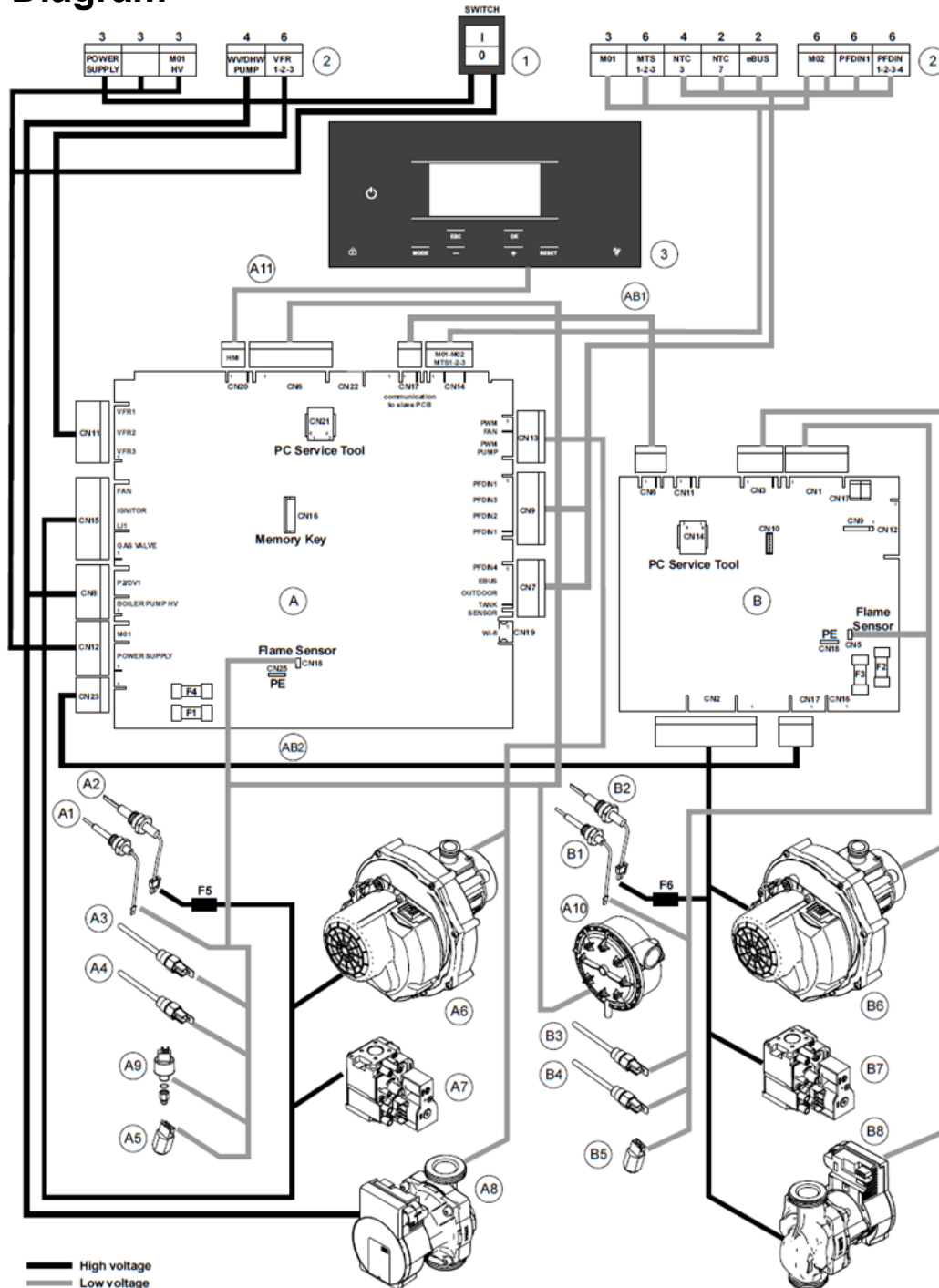

Pos	Description	Pos	Description	Pos	Description	Pos	Description
1	Main switch 230V	A5	Return temp sensor	B1	Ionisation electrode	AB1	Fuse 6.3A - 250V
2	Electrical connect.	A6	Fan unit	B2	Glow igniter	AB2	Fuse 6.3A - 250V
3	HMI	A7	Gas valve	B3	Flow temp sensor	F1	Fuse 6.3A - 250V
A	Master PCB	A8	Circulation pump	B4	2 nd flow temp sensor	F2	Fuse 6.3A - 250V
A1	Ionisation electrode	A9	Water pressure sensor	B5	Return temp sensor	F3	Fuse 3.15A - 250V
A2	Glow igniter	A10	Air pressure switch	B6	Fan unit	F4	Fuse 3.15A - 250V
A3	Flow temp sensor	A11	HMI comm cable LV	B7	Gas valve	F5	Fuse 6.3A-250V-4.2I ² t-fast
A4	2 nd flow temp sensor	B	Slave PCB	B8	Circulation pump	F6	Fuse 6.3A-250V-4.2I ² t-fast

Boiler Installation

Electrical connection

The 3 MIXING ZONES Clip Manager is an accessory that manages up to 3 heating zone (direct, mixing or a combination of them) directly from boiler.

This accessory is connected to the boiler via eBus and it can be connected to Ariston Thermo Group heating system (boilers, heat pumps, solar applications, etc.) through the eBus connection.

A special setting of a second 3 MIXING ZONES Clip permits to connect two clips via eBUS, in order to control up to 6 zones (direct, mixing or a combination of them). This means, connect one clip-in on a single boiler and up to 2 clip-in into a cascade, in order to manage a maximum of 6 zone.

Every heating zone has to be connected through a sensor or thermostat, a pump and, if present, a mixing valve

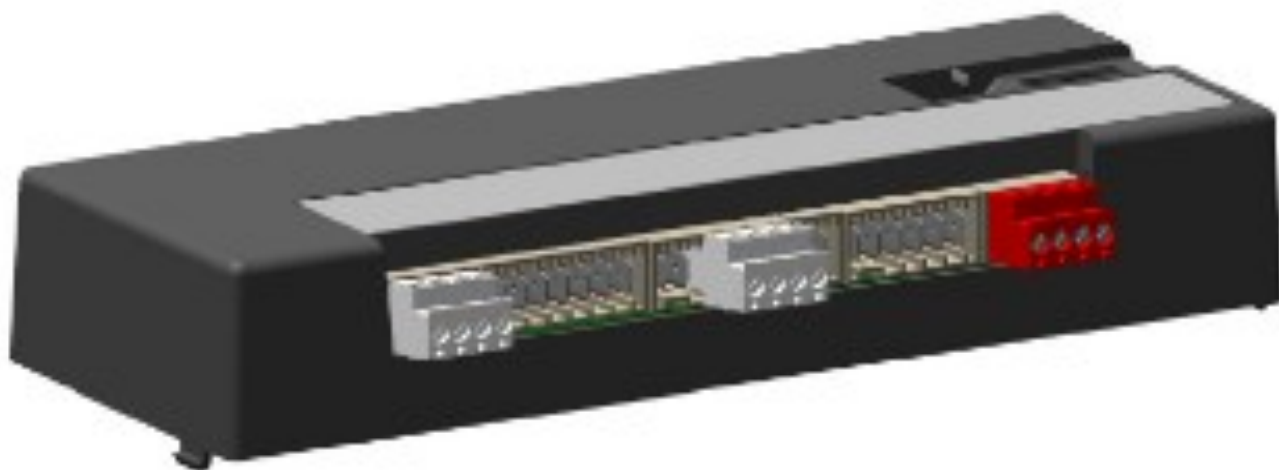

3 MIXING ZONES Clip Manager

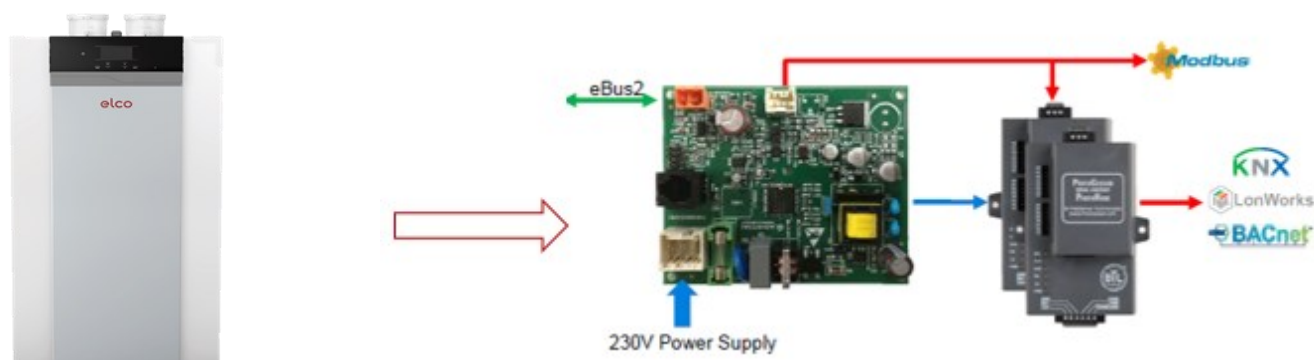

NEW BUS modules for BMS management: Complete integration with building management systems is possible with

Thision L Plus boilers with the supported protocols MODBUS, KNX, LON, BACNET

*Separate accessories for different protocols is required.

Standard Schemes

Elco Thision L Plus + 1 Mixing circuit +1 Direct circuit + Low loss header

Hydraulic Schematic

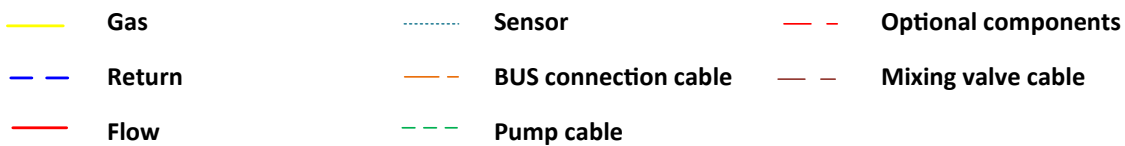
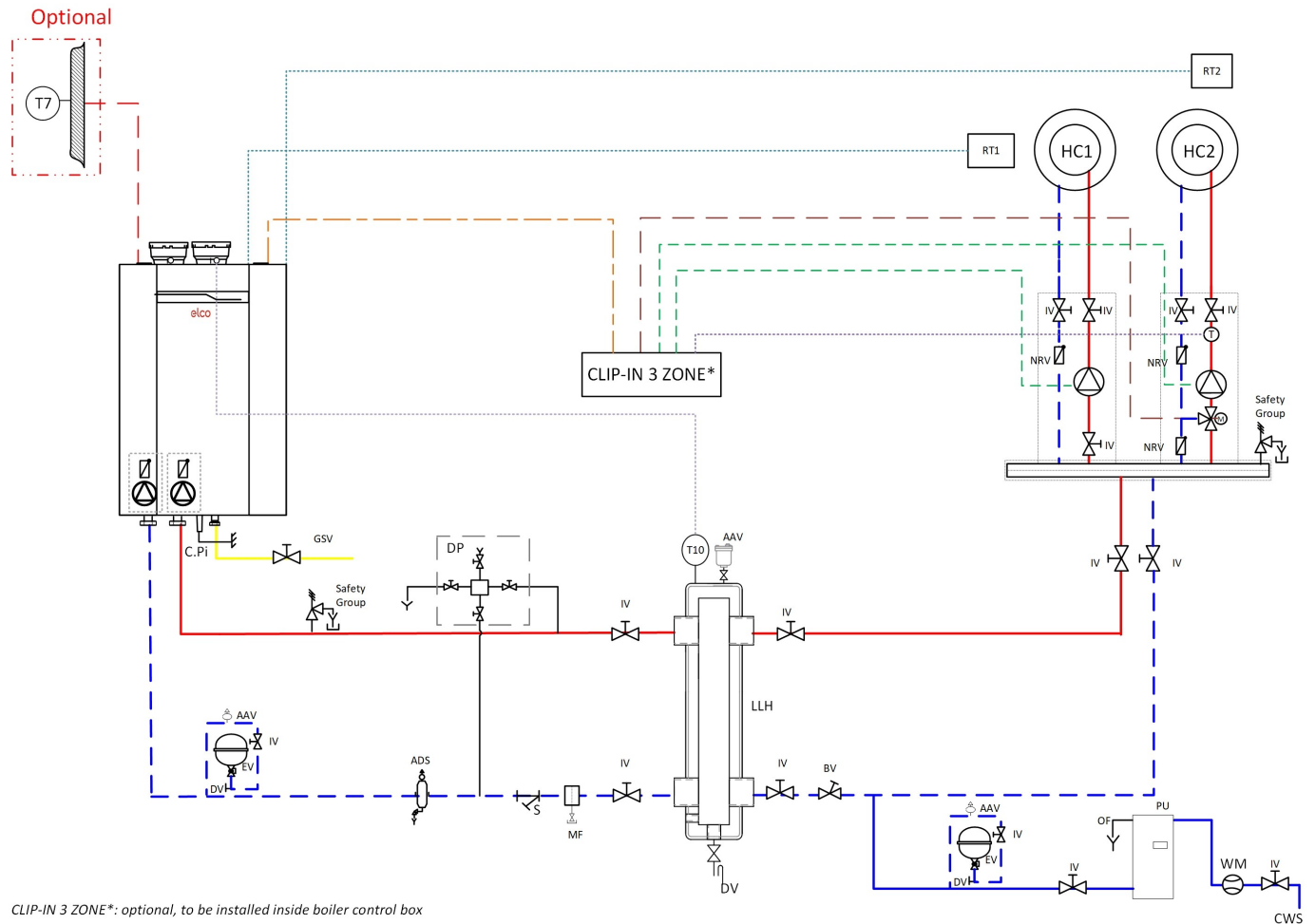

AAV Automatic air vent	HC Heating Circuit	T Flow sensor
ADS Air dirt separator	IV Isolation valve	T10 Common sensor flow
BV Balancing valve	LLH Low loss header	T7 Outdoor sensor
C.Pi Condensing pipe	MF Dirt separator magnetic filter	WM Water meter
CWS Cold water supply	NRV Non return valve	
DP Dosing pot	OF Overflow pipe	
DV Drain valve	PU Pressurization unit	
EV Expansion vessel	RT1/RT2 Room thermostat (on/off)	
GSV Gas shut off valve	S Strainer	

Standard Schemes

Elco Thision L Plus + 1 Mixing circuit +1 Direct circuit + Low loss header

Electrical connections

BOILER MOTHERBOARD

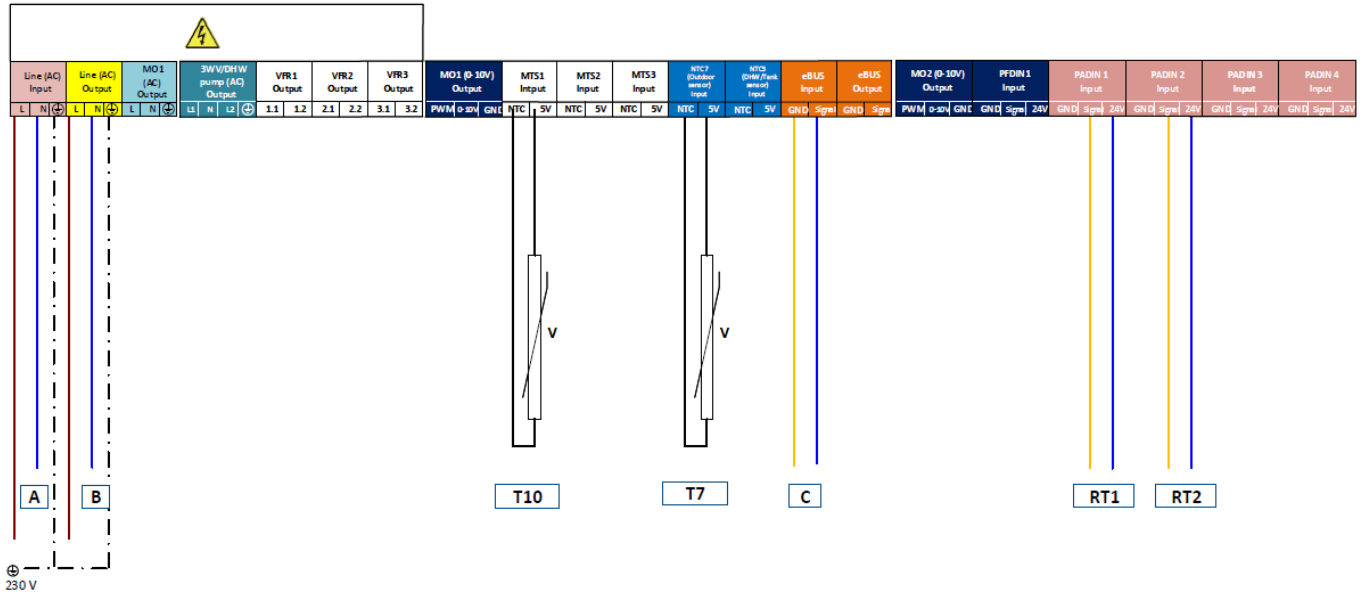

A : Main power supply (230V @50Hz)

C : Clip-In 3 zone

B : Clip In power (230V @50Hz)

RT1: Room thermostat (On/Off)

T10: Common flow temperature sensor (10KΩ)

RT2: Room thermostat (On/Off)

CLIP-IN ZONE MANAGER

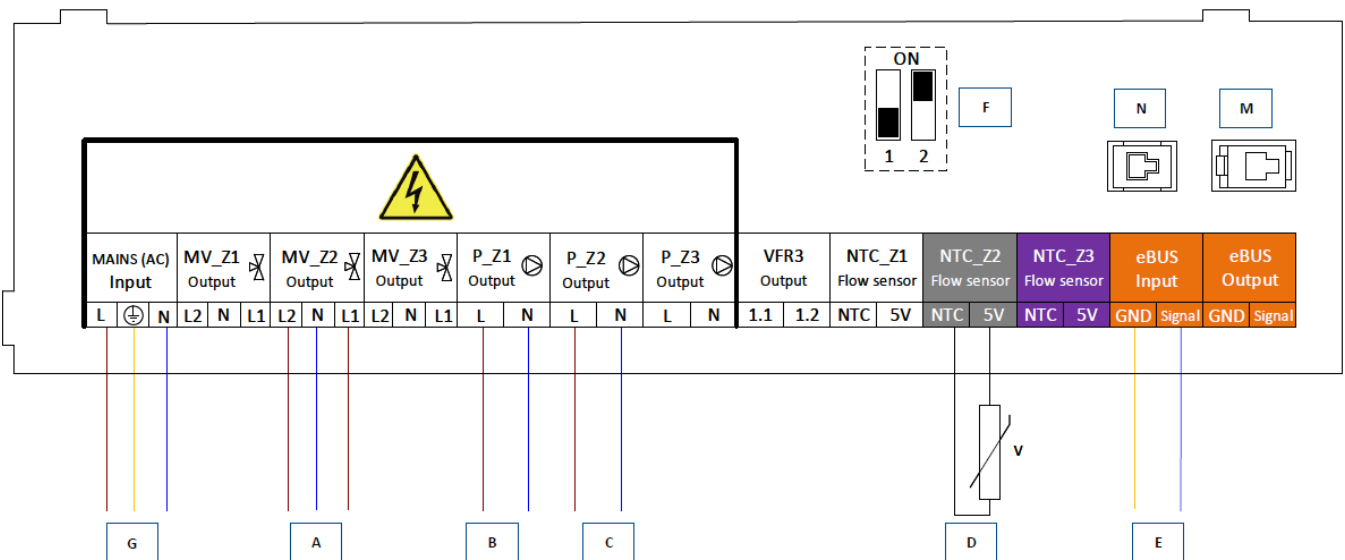

A : Mixing Valve HC2

E: Clip In connection to boiler Ebus Input

B : Heating circuit pump HC1

F: DIP-switch 2 must be set in ON position

C : Heating circuit pump HC2

G: Main power connection to boiler board

D: Flow sensor HC2

Standard Schemes

Elco Thision L Plus + 1 Mixing circuit +1 Direct circuit + Domestic Hot Water +Low loss header

Hydraulic Schematic

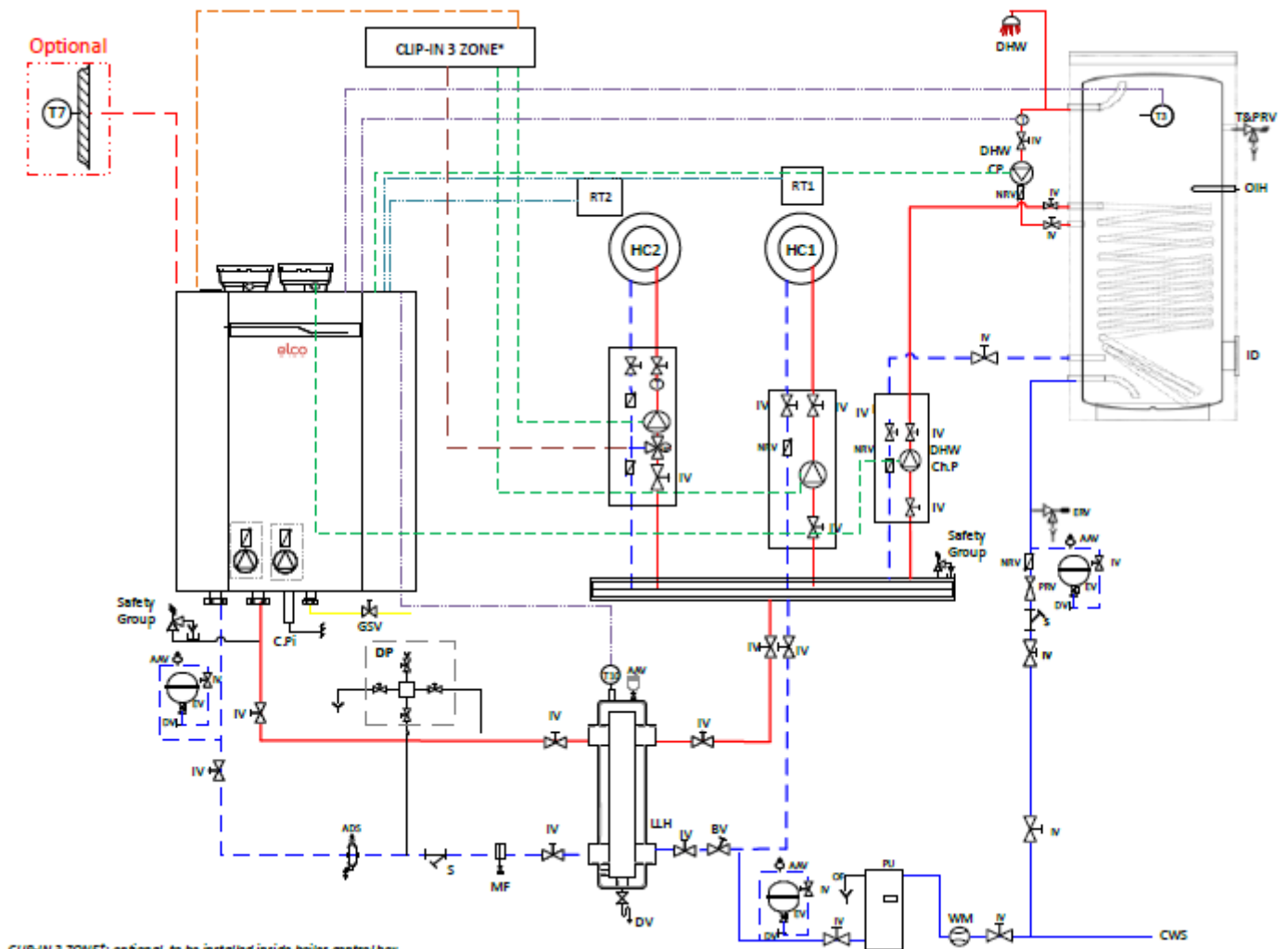

CLIP-IN 3 ZONE*: optional, to be installed inside boiler control box

- | | | |
|----------|------------------------|---------------------------|
| — Gas | Sensor | - - - Optional components |
| — Return | — BUS connection cable | - - - Mixing valve cable |
| — Flow | - - - Pump cable | |

- | | | |
|----------------------------|-----------------------------------|---|
| AAV Automatic air vent | ERV Expansion relief valve | OF Overflow pipe |
| ADS Air dirt separator | EV Expansion vessel | OIH Optional immersion heater |
| BV Balancing valve | GSV Gas shut off valve | PU Pressurisation unit |
| C.Pi Condensing pipe | HC Heating Circuit | RT1/RT2 Room thermostat (on/off) |
| Ch.P DHW Charging Pump | ID Inspection door | S Strainer |
| CP DHW Re-circulating Pump | IV Isolation valve | T&PRV Temperature and pressure relief valve |
| CWS Cold water supply | LLH Low loss header | T Flow sensor |
| DP Dosing pot | MF Dirt separator magnetic filter | T10 Common sensor flow |
| DV Drain valve | NRV Non return valve | T7 Outdoor sensor |

Standard Schemes

Elco Thision L Plus + 1 Mixing circuit +1 Direct circuit + Domestic Hot Water +Low loss header

Electrical connections

BOILER MOTHERBOARD

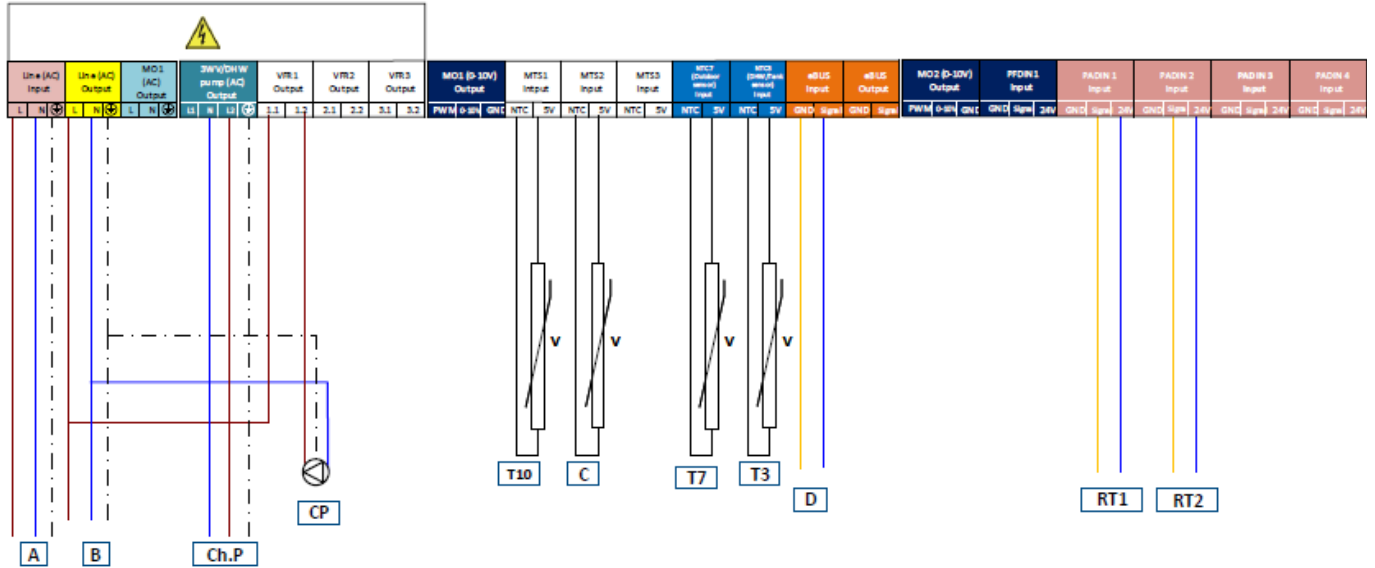

A : Main power supply (230V @50Hz)

B : Clip In power (230V @50Hz)

Ch.P : DHW Charging pump(230/120 VAC, 1A max)

CP: DHW re-circulating pump (230 VAC, 2A max)

T10: Common flow temperature sensor (10KΩ)

C: DHW re-circulating temperature sensor(10KΩ)

T3: DHW temperature sensor(10KΩ)

D : Clip-In 3 zone

RT1: Room thermostat (On/Off)

RT2: Room thermostat (On/Off)

T7 : Outdoor sensor (optional)(1KΩ)

CLIP-IN ZONE MANAGER

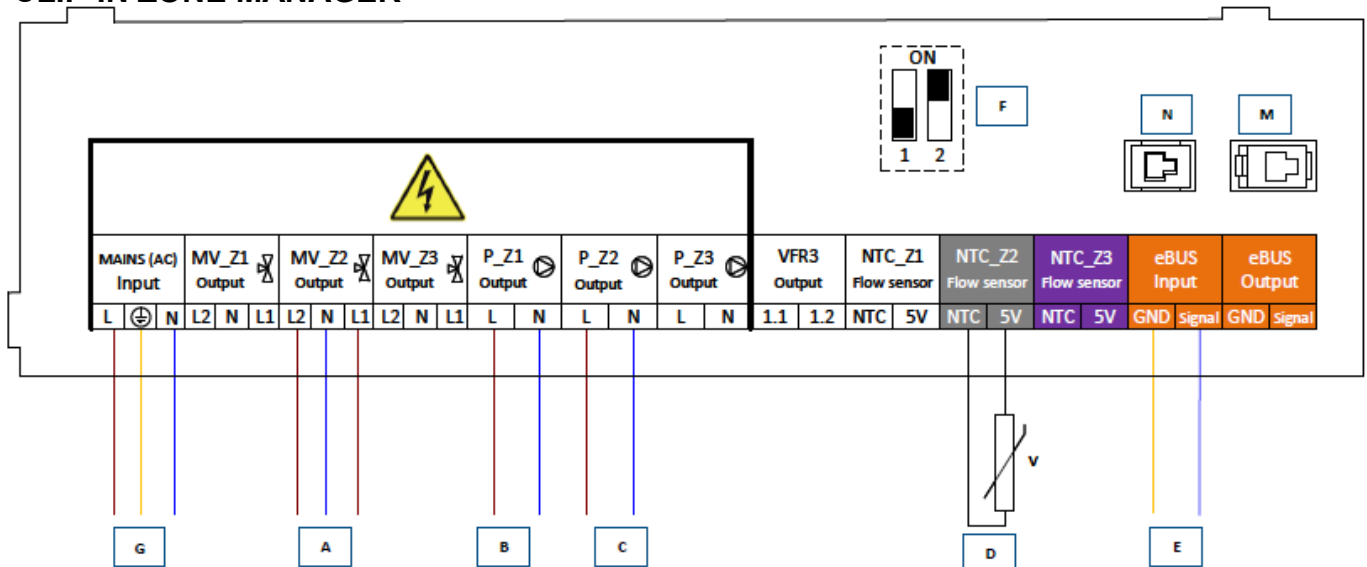

A : Mixing Valve HC2

B : Heating circuit pump HC1

C : Heating circuit pump HC2

D: Flow sensor HC2

E: Clip In connection to boiler Ebus Input

F: DIP-switch 2 must be set in ON position

G: Main power connection to boiler board

Standard Schemes

Elco Thision L Plus + 1 Mixing circuit +1 Direct circuit + Domestic Hot Water with 3 way valve +Low loss header

Hydraulic Schematic

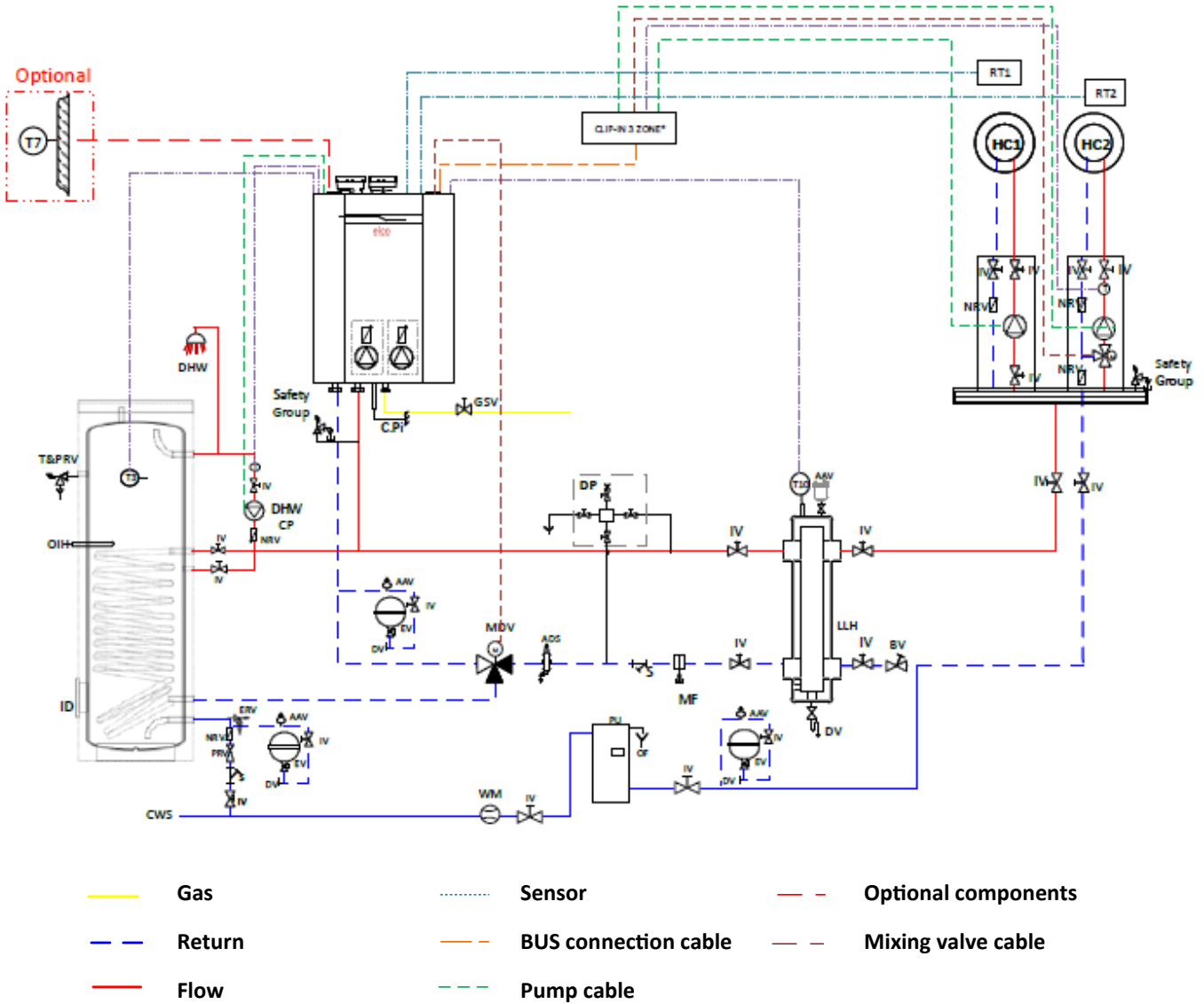

AAV	Automatic air vent	EV	Expansion vessel	OIH	Optional immersion heater
ADS	Air dirt separator	GSV	Gas shut off valve	PU	Pressurisation unit
BV	Balancing valve	HC	Heating Circuit	RT1/RT2	Room thermostat (on/off)
C.Pi	Condensing pipe	ID	Inspection door	S	Strainer
Ch.P	DHW Charging Pump	IV	Isolation valve	T&PRV	Temperature and pressure relief valve
CP	DHW Re-circulating Pump	LLH	Low loss header	T	Flow sensor
CWS	Cold water supply	MDV	Motorised diverter valve	T10	Common sensor flow
DP	Dosing pot	MF	Dirt separator magnetic filter	T7	Outdoor sensor
DV	Drain valve	NRV	Non return valve	WM	Water meter
ERV	Expansion relief valve	OF	Overflow pipe		

Standard Schemes

Elco Thision L Plus + 1 Mixing circuit +1 Direct circuit + Domestic Hot Water with 3 way valve +Low loss header

Electrical connections

BOILER MOTHERBOARD

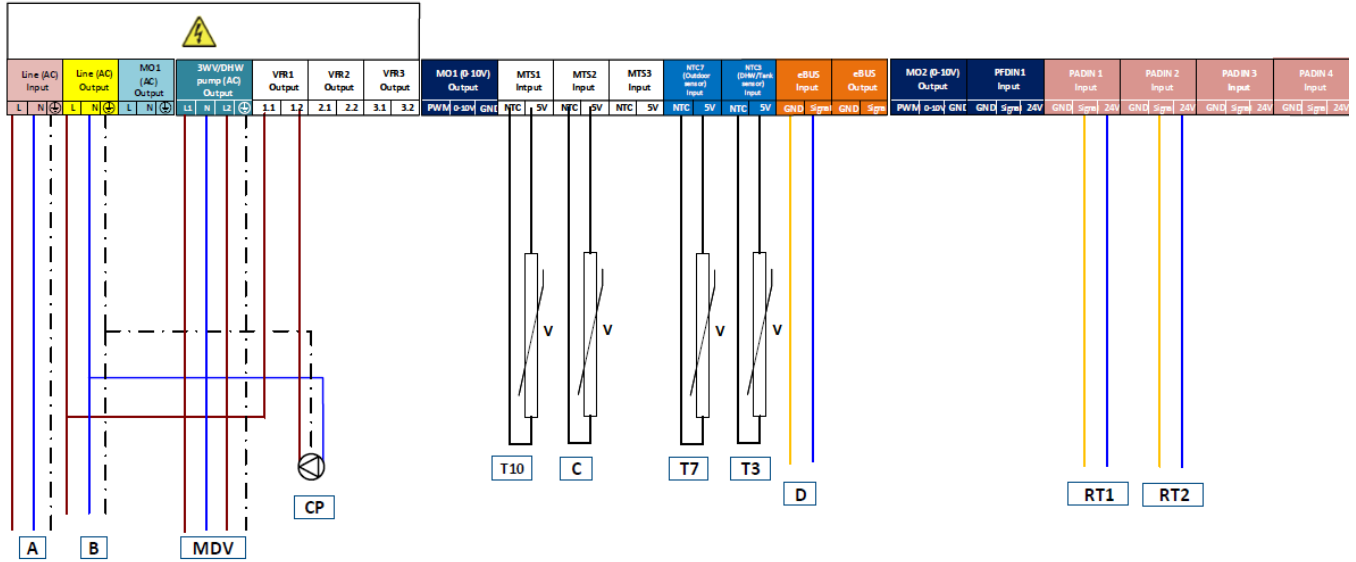

A : Main power supply (230V @50Hz)

B : Clip In power (230V @50Hz)

MDV : Motorised diverter Valve (230/120 VAC, 1A max)

CP: DHW re- circulating pump (230 VAC, 2A max)

T10: Common flow temperature sensor (10KΩ)

C : DHW re-circulating temperature sensor (10KΩ)

T3: DHW temperature sensor(10KΩ)

D : Clip-In 3 zone

RT1: Room thermostat (On/Off)

RT2: Room thermostat (On/Off)

T7 : Outdoor sensor (optional)(1KΩ)

CLIP-IN ZONE MANAGER

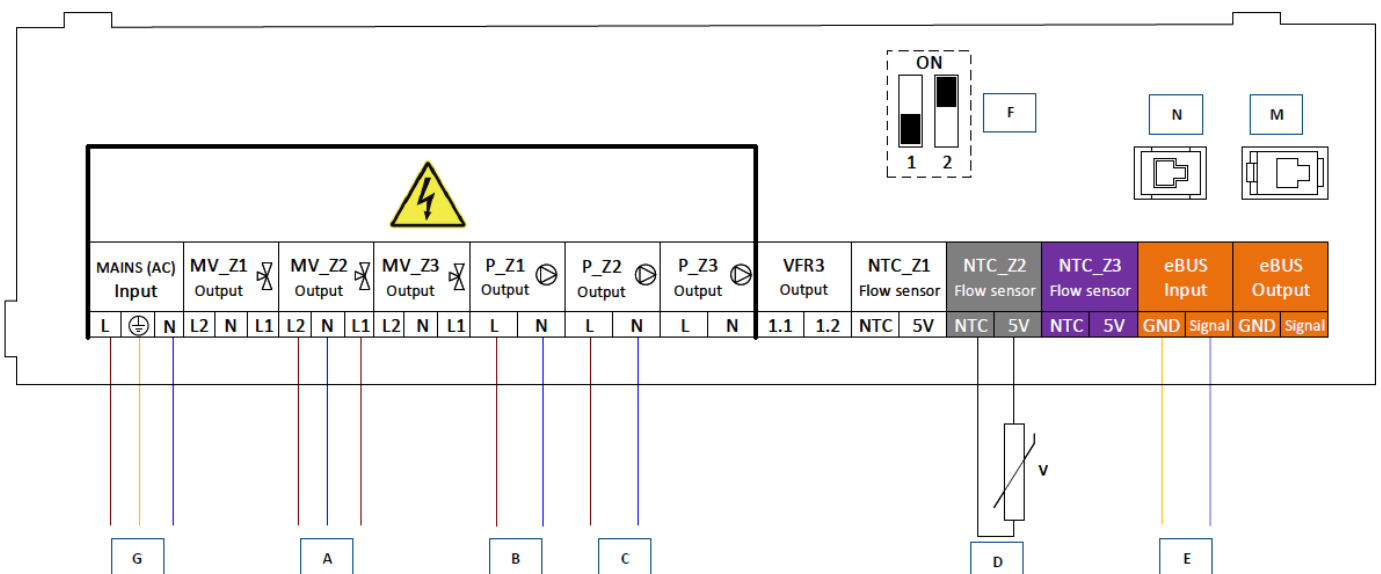

A : Mixing Valve HC2

B : Heating circuit pump HC1

C : Heating circuit pump HC2

D: Flow sensor HC2

E: Clip In connection to boiler Ebus Input

F: DIP-switch 2 must be set in ON position

G: Main power connection to boiler board

Standard Schemes

Elco Thision L Plus + 2 Mixing circuit +1 Direct circuit + Domestic Hot Water with 3 way valve +Low loss header

Hydraulic Schematic

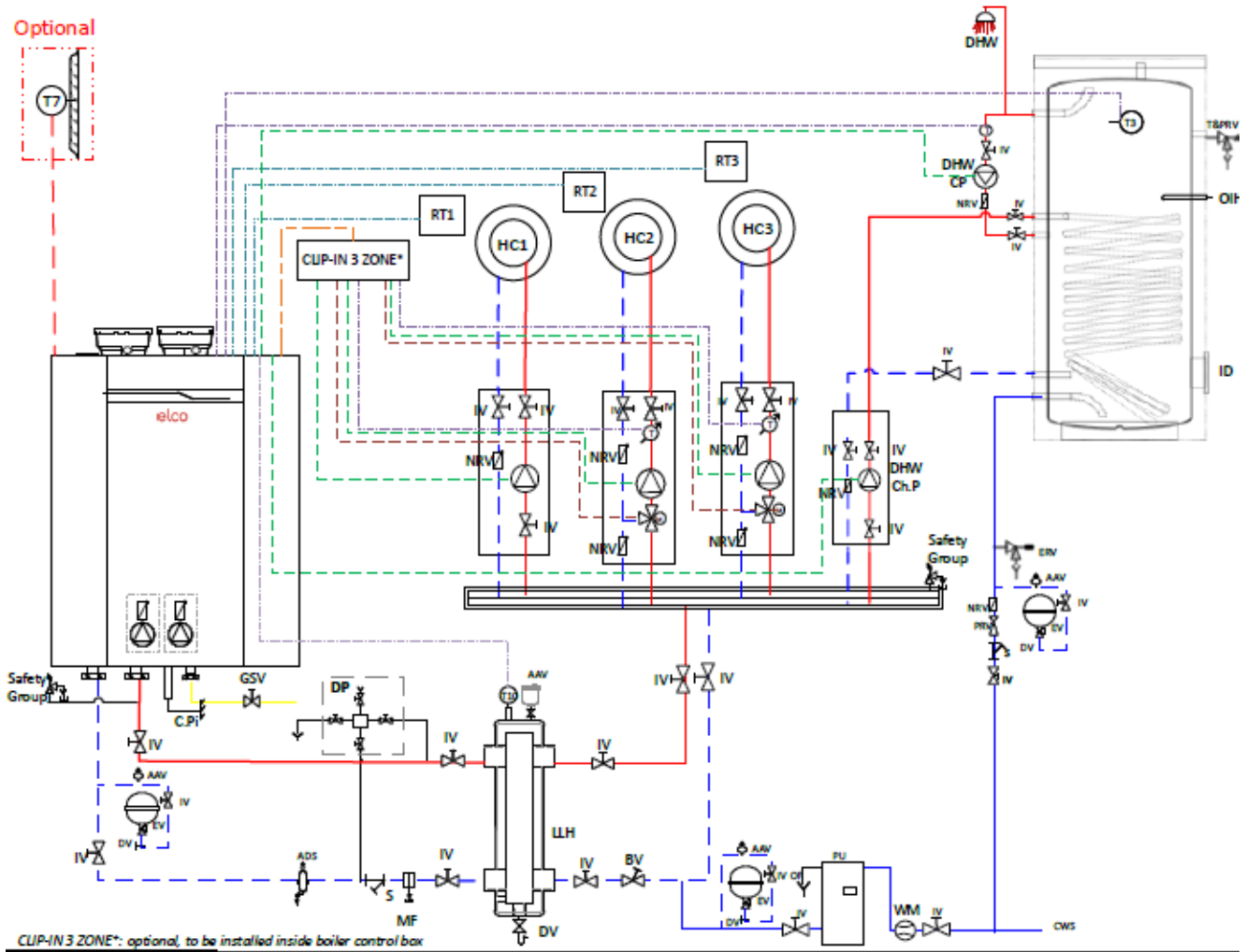

- | | | |
|--|---|---|
| — Gas | — Sensor | — Optional components |
| — Return | — BUS connection cable | — Mixing valve cable |
| — Flow | — Pump cable | |

AAV	Automatic air vent	EV	Expansion vessel	PU	Pressurisation unit
ADS	Air dirt separator	GSV	Gas shut off valve	RT1/RT2/RT3	Room thermostat (on/off)
BV	Balancing valve	HC	Heating Circuit	S	Strainer
C.Pi	Condensing pipe	ID	Inspection door	T&PRV	Temperature and pressure relief valve
Ch.P	DHW Charging Pump	IV	Isolation valve	T	Flow sensor
CP	DHW Re-circulating Pump	LLH	Low loss header	T10	Common sensor low
CWS	Cold water supply	MF	Dirt separator magnetic filter	T7	Outdoor sensor
DP	Dosing pot	NRV	Non return valve	WM	Water meter
DV	Drain valve	OF	Overflow pipe		
ERV	Expansion relief valve	OIH	Optional immersion heater		

Standard Schemes

Elco Thision L Plus + 1 Mixing circuit +1 Direct circuit + Domestic Hot Water with 3 way valve +Low loss header

Electrical connections

BOILER MOTHERBOARD

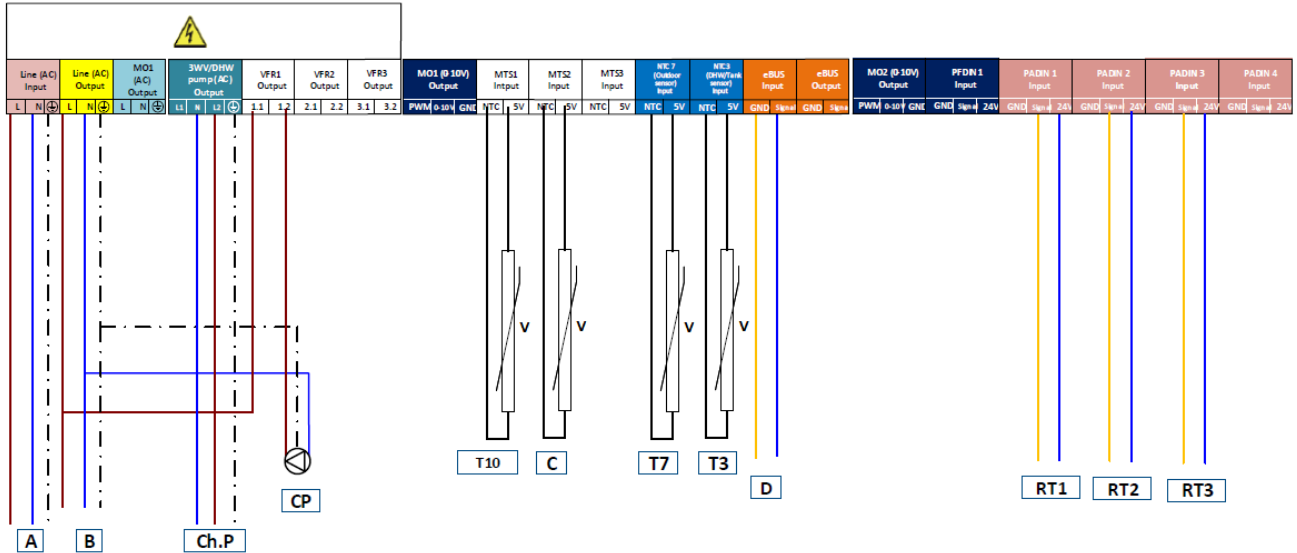

A : Main power supply (230V @50Hz)

B : Clip In power (230V @50Hz)

Ch.P : DHW Charging pump(230/120 VAC, 1A max)

CP: DHW re- circulating pump (230

VAC, 2A max)

T10: Common flow temperature sensor (10KΩ)

C: DHW re-circulating temperature sensor(10KΩ)

T3: DHW temperature sensor(10KΩ)

D : Clip-In 3 zone

RT1: Room thermostat (On/Off)

RT2: Room thermostat (On/Off)

RT3: Room thermostat (On/Off)

T7 : Outdoor sensor (optional)(1KΩ)

CLIP-IN ZONE MANAGER

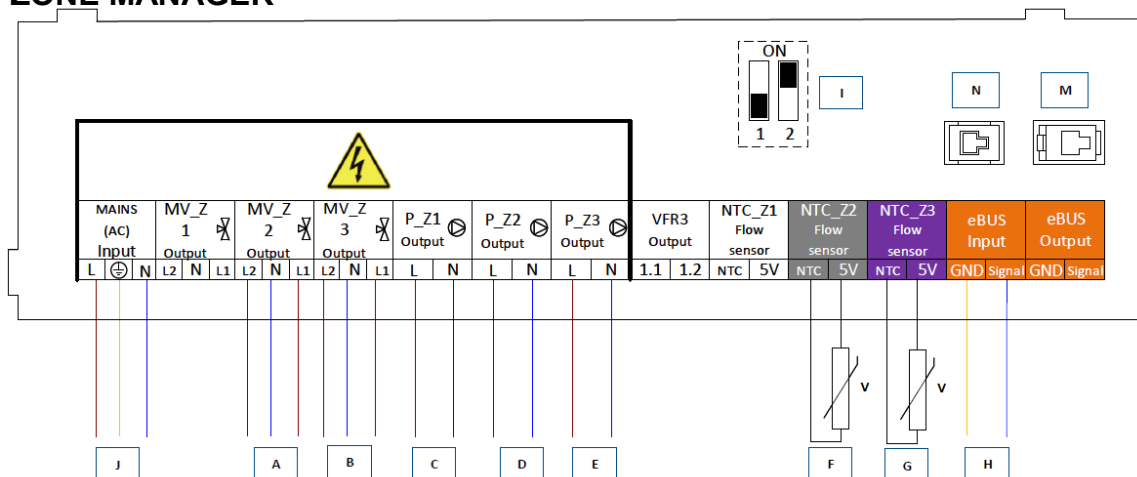

A : Mixing Valve HC2

B : Mixing Valve HC3

C : Heating circuit pump HC1

D : Heating circuit pump HC2

E : Heating circuit pump HC3

F: Flow sensor HC2

G: Flow sensor HC3

H: Clip In connection to boiler Ebus Input

I: DIP-switch 2 must be set in ON position

J: Main power connection to boiler board

Standard Schemes

Elco Thision L Plus + 1 Direct circuit + 0-10V controller +Low loss header

Hydraulic Schematic

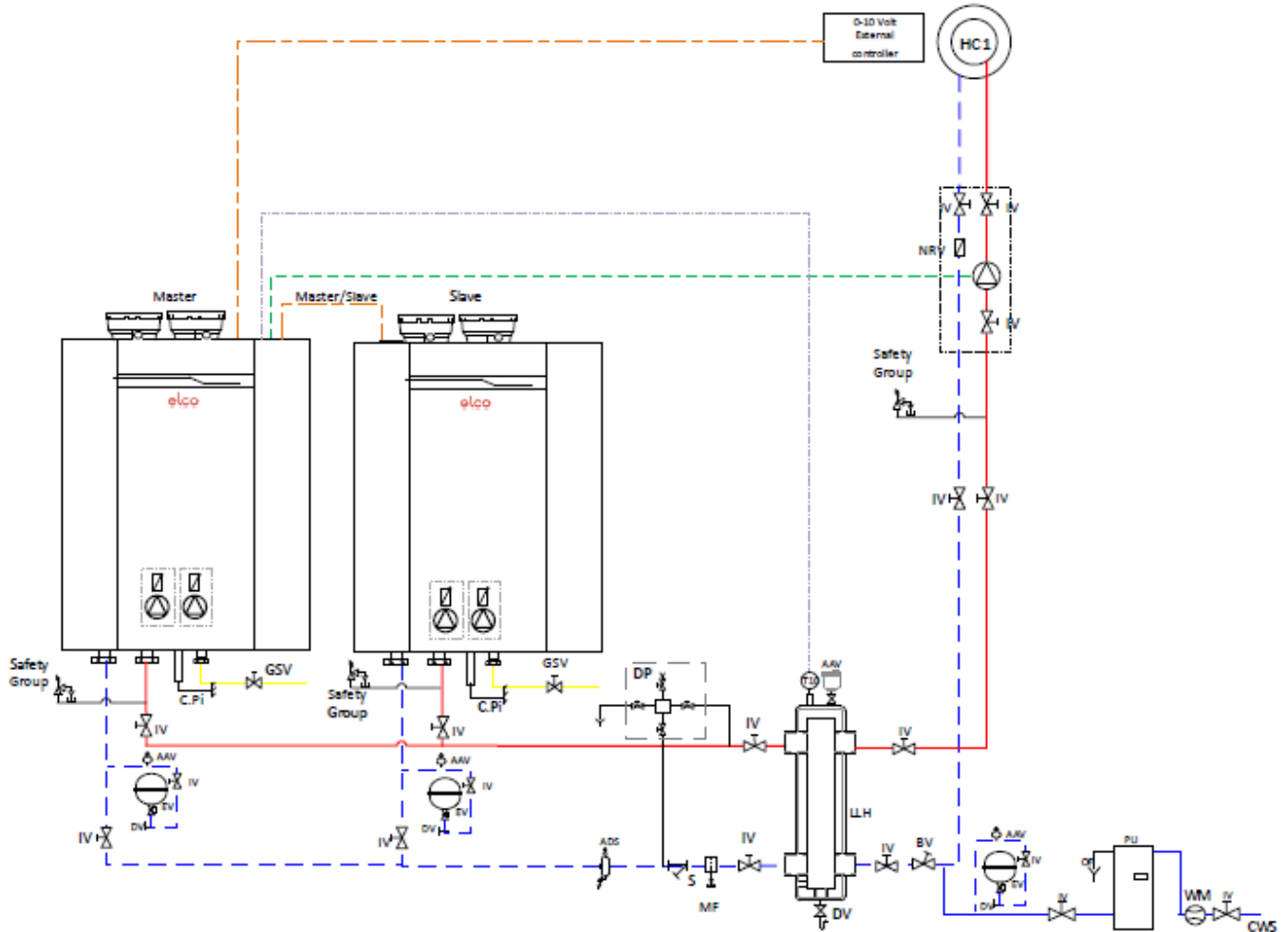

- | | | |
|--|--|--|
| — Gas | — Sensor | — Optional components |
| — Return | — BUS connection cable | — Mixing valve cable |
| — Flow | — Pump cable | |

- | | | |
|------------------------|-----------------------------------|------------------------|
| AAV Automatic air vent | EV Expansion vessel | OF Overflow pipe |
| ADS Air dirt separator | GSV Gas shut off valve | PU Pressurisation unit |
| BV Balancing valve | HC Heating Circuit | S Strainer |
| C.Pi Condensing pipe | IV Isolation valve | T10 Common sensor flow |
| CWS Cold water supply | LLH Low loss header | WM Water meter |
| DP Dosing pot | MF Dirt separator magnetic filter | |
| DV Drain valve | NRV Non return valve | |

Standard Schemes

Elco Thision L Plus + 1 Direct circuit + 0-10V controller +Low loss header

Electrical connections

MASTER BOILER MOTHERBOARD

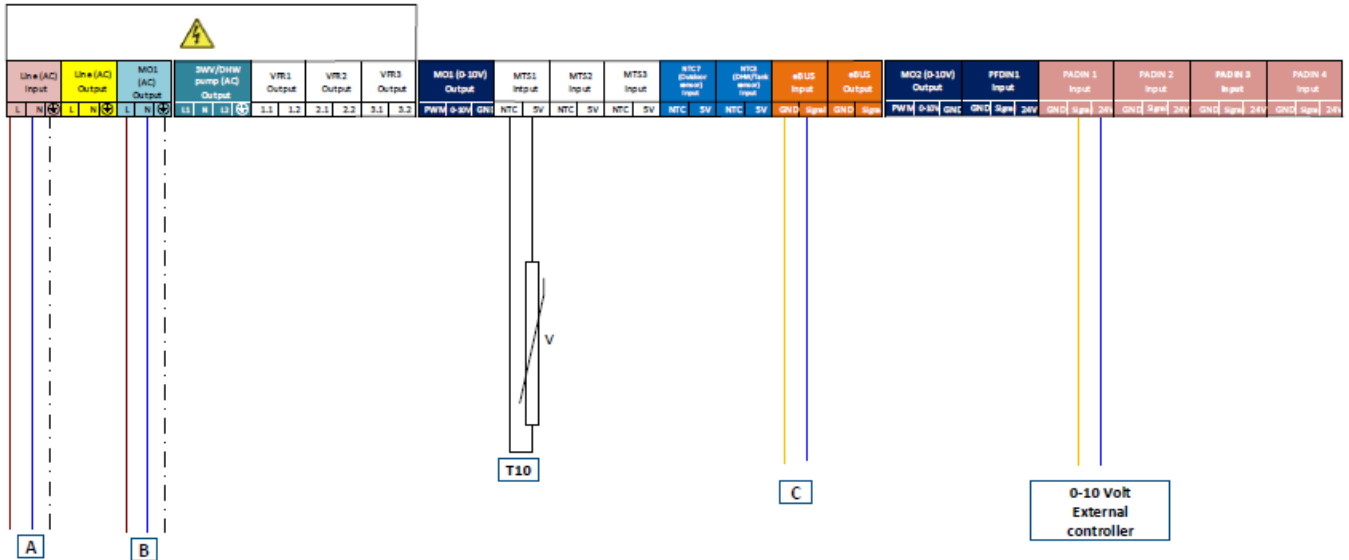

A : Main power supply (230V @50Hz)

C : Cascade connection to slave board

B : Heating circuit pump HC1(230V @50Hz)

External controller: 0-10 Volt

T10: Common flow temperature sensor (10KΩ)

SLAVE BOILER MOTHERBOARD

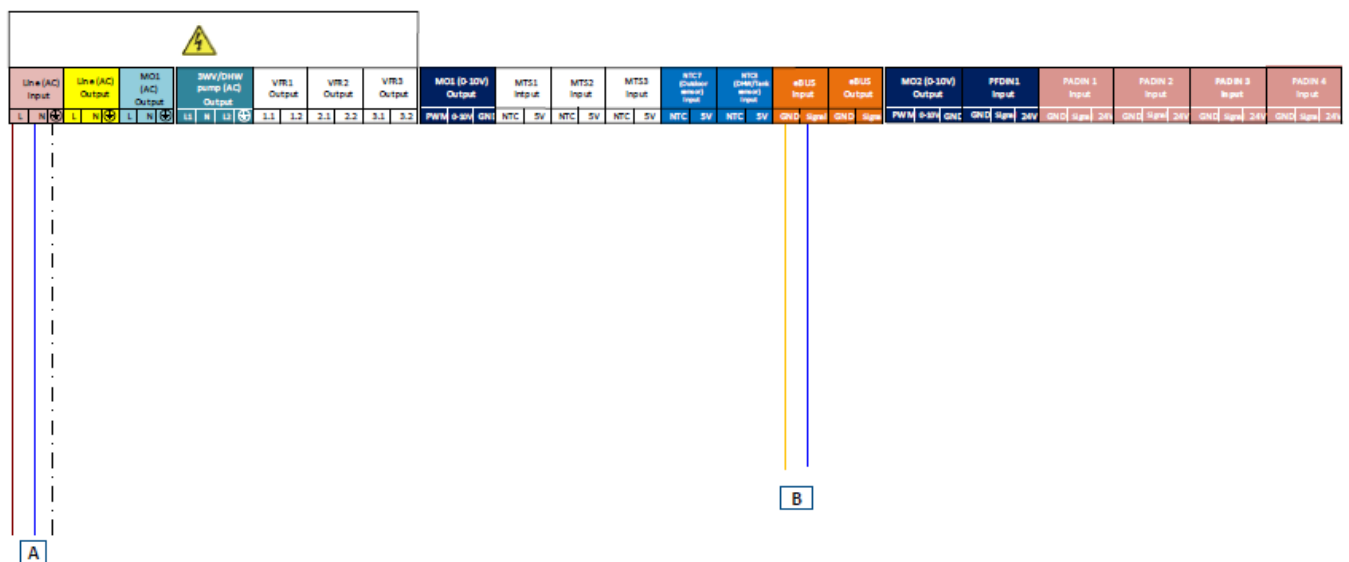





A : Main power supply (230V @50Hz)

B : Cascade connection to the master board

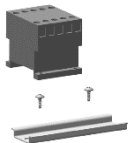
Accessories

Controls

	DESCRIPTION	SAP CODE
	LLH / DHW SENSOR TH/R L PLUS Sensor for use as T10 Common flow temperature sensor or as T4 Domestic hot water temperature sensor. Resistance value NTC 10K	3905045
	ROOM FAN EXT.GAS VALVE SINGLE BOILER TH/R L PLUS Relay set to control either an external gas valve or room ventilation.	3905103
	BMS BUS MODULE LON TH/R L PLUS	3905120
	BMS BUS MODULE BACNET TH/R L PLUS	3905121
	BMS BUS MODULE MODBUS TH/R L PLUS	3905122
	BMS BUS MODULE KNX TH/R L PLUS	3905123
	The BMS BUS Module allows communication between a BMS-system and the boiler using LON/BACNET/MODBUS/KNX protocol. For each protocol there is a dedicated accessory.	
	CLIP-IN 3 ZONES MANAGER TH/R L PLUS The clip-in 3 zones manager can control 3 mixed heating circuits. It has connections for 3 flow temperature sensors, 3 heating circuit pumps and 3 mixing valves. Furthermore there is a programmable volt-free contact.	3905124
	OUTDOOR SENSOR TH/R L PLUS Resistance value NTC 1K	3905127
	ZONE SENSOR TH/R L PLUS Sensor for use as heating circuit flow temperature sensor. Resistance value NTC 10K	3905128



Accessories

Gas Single boiler

	DESCRIPTION	SAP CODE
	INAIL KIT SINGLE BOILER 60-70KW TH/R L PLUS Shut off Valve size ¾"	3905097
	INAIL KIT SINGLE BOILER 100-140KW TH/R L PLUS Shut off Valve size 1"	3905098
	INAIL KIT SINGLE BOILER 170-200KW TH/R L PLUS Shut off Valve size 1.¼"	3905099
<p>The INAIL gas valve is a capillary sensor controlled slam shut valve that closes the gas supply when the capillary sensor detects a water temperature of 97°C. Connection boiler side: G 1.¼" Flat gasket surface Connection system side: G 1"</p>		
	MIN. GAS PRESSURE SWITCH SINGLE BOILER TH/R L PLUS The minimum gas pressure switch will interrupt the boiler operation in case the gas supply pressure drops below the set value on the switch. Setting of the switch depends on the used gas type. Connection boiler side: G 1.¼" Flat gasket surface Connection system side: G 1"	3905101
	GAS FILTER 60-140KW SINGLE BOILER TH/R L PLUS Filter size ¾" (GF507/1)	3905104
	GAS FILTER 170-200KW SINGLE BOILER TH/R L PLUS Filter size 1" (GF510/1)	3905105
<p>It is recommended to use a gas filter in the gas connection to the boiler to prevent impurities from entering the boilers. Connection boiler side: G 1.¼" Flat gasket surface Connection system side: G 1"</p>		
	TAE/TAS GAS VALVE SINGLE BOILER CH TH/R L PLUS	3905108
	TAE/TAS GAS VALVE SINGLE BOILER DHW TH/R L PLUS	3905109
<p>When the temperature of the TAE/TAS valve body reaches 100°C (for example in case of fire) the valve will shut off the gas supply to the boiler. Connections system side: Water: G 2" Flat gasket surface DHW: G 1.¼" Gas: Rp 1.¼"</p>		
	WATER-GAS CONNECTION KIT SINGLE BOILER TH/R L PLUS Adapters for water and gas connections. Water connection: G 2" Flat gasket surface to G1½" internal Gas connection: G 1.¼" Flat gasket surface to G1" internal	3905117
	LPG KIT COMPACT ENGINE SINGLE BOILER TH/R L PLUS	3905118
	LPG KIT STANDARD ENGINE SINGLE BOILER TH/R LPLUS	3905119
<p>The LPG conversion kit consists of new burner stones and an injector for the mixing system. The kit contains components for one engine.</p>		

Accessories

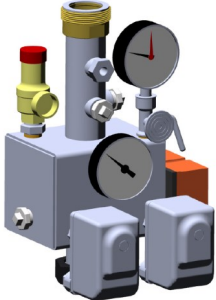
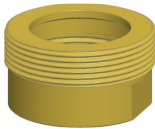
Hydraulics Single boiler

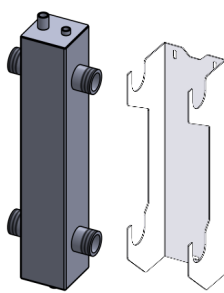
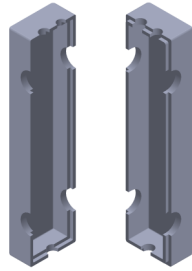
	DESCRIPTION	SAP CODE
	<p>INAIL KIT SINGLE BOILER WATER TH/R L PLUS The INAIL kit contains the following components: Safety thermostat 100°C with manual reset Maximum water pressure switch Minimum water pressure switch Thermometer Pressure gauge Safety valve 4.5 bar</p>	3905100
	<p>WATER-GAS CONNECTION KIT SINGLE BOILER TH/R L PLUS Adapters for water and gas connections. Water connection: G 2" Flat gasket surface to G 1½" internal Gas connection: G 1.¼" Flat gasket surface to G 1" internal</p>	3905117
	<p>CONNECTION KIT BOILER CH TLPLUS Kit contains shut off valves for water flow, return and gas connections and a 6 bar safety valve. Connections system side: Water: G 2" Flat gasket surface Gas: Rp 1.¼"</p>	3905150
	<p>CONNECTION KIT BOILER DHW TLPLUS Kit contains shut off valves for flow, return and gas connection, 3-port DHW valve and a 6 bar safety valve. Connections system side: Water: G 2" Flat gasket surface DHW: G 1.¼" Gas: Rp 1.¼"</p>	3905151
	<p>LOW LOSS HEADER dT10-20K WALL HUNG TLPLUS Low loss header kit with bracket for wall fixation, deaerator and flexible hoses to connect the low loss header to the boiler. For connection possibilities and dimensional sketch, please see following page.</p>	3905173
	<p>INSULATION LLH dT10-20K WALL HUNG TLPLUS Insulation for the low loss header kit 3905173</p>	3905175

Accessories

Hydraulics Single boiler

Dimensional sketch for 3905173 LLH dT10-20K WALL HUNG TLPLUS

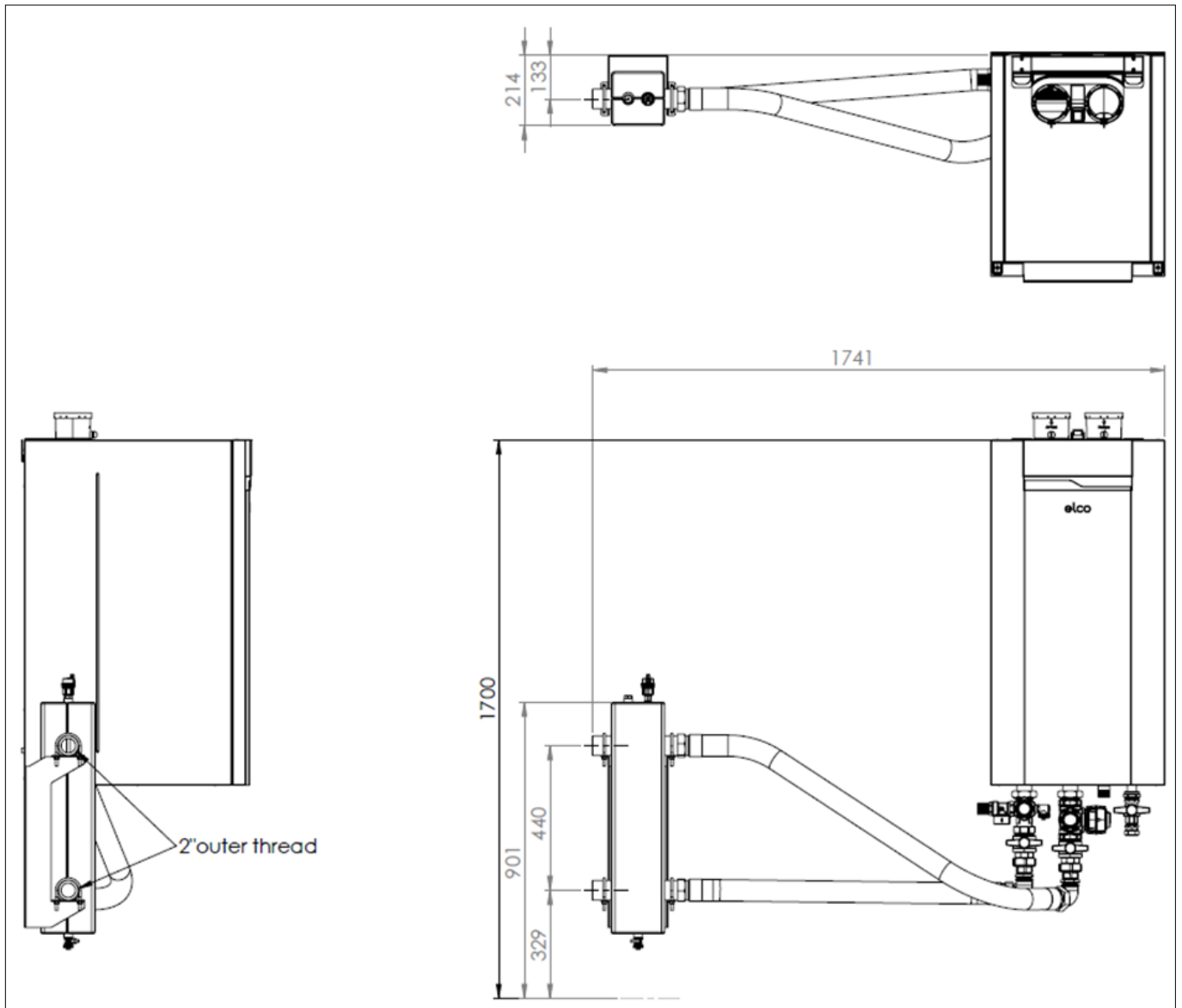

Accessories

Hydraulics Single boiler

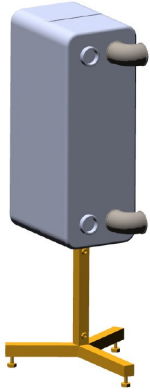

DESCRIPTION	SAP CODE
PLATE HEAT EXCHANGER dT10K 60-100kW TLPLUS	3905186
PLATE HEAT EXCHANGER dT10K 120-200kW TLPLUS	3905187
PLATE HEAT EXCHANGER dT15K 60-100kW TLPLUS	3905188
PLATE HEAT EXCHANGER dT15K 120-200kW TLPLUS	3905189
PLATE HEAT EXCHANGER dT20K 60-100kW TLPLUS	3905190
PLATE HEAT EXCHANGER dT20K 120-200kW TLPLUS Plate heat exchanger with floor standing support and insulation. Secondary connections: G2"	3905191



PHE CONNECTION KIT TLPLUS Flexible pipes and connectors with deaerator, temperature and pressure gauge for connecting the plate heat exchanger kit to the boiler.	3905192
---	---------



PHE EXPANSION VESSEL KIT TLPLUS 4L Expansion vessel for use with the plate heat exchanger kit. With 1/2" T-piece to connect to the pressure gauge connection of the connection kit.	3905193
---	---------

Plate heat exchangers specifications:

			60	70	100	120	140	170	200
Primary circuit	dT 20K	m3/h	2,45	2,81	3,88	4,76	5,62	6,68	7,75
Expansion vessel		L	4	4	4	4	4	4	4
Secondary circuit	dT 20K	PHE type	CB112-38M	CB112-38M	CB112-38M	CB112-68M	CB112-68M	CB112-68M	CB112-68M
		SAP code	3905190	3905190	3905190	3905191	3905191	3905191	3905191
		m3/h	2,45	2,81	3,88	4,76	5,62	6,68	7,75
		kPa	4,3	5,8	10,7	5,0	7,2	9,9	13,2
	dT 15K	PHE type	CB112-26L	CB112-26L	CB112-26L	CB112-52L	CB112-52L	CB112-52L	CB112-52L
		SAP code	3905188	3905188	3905188	3905189	3905189	3905189	3905189
		m3/h	3,26	3,75	5,17	6,35	7,49	8,91	10,34
		kPa	7,7	10,5	19,3	7,2	10,4	14,4	19,1
	dT 10K	PHE type	CB110-26M	CB110-26M	CB110-26M	CB110-56M	CB110-56M	CB110-56M	CB110-56M
		SAP code	3905186	3905186	3905186	3905187	3905187	3905187	3905187
		m3/h	4,89	5,62	7,76	9,53	11,23	13,36	15,51
		kPa	8,2	11,2	20,7	7,3	10,3	14,5	19,3

Accessories

Hydraulics Single boiler

dT10K
CB110-26M
CB110-56M

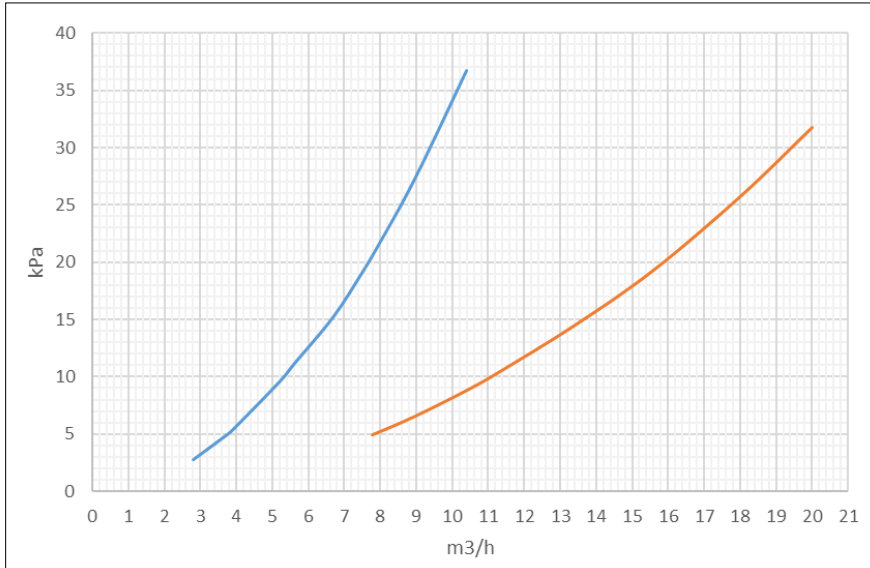

dT15K
CB112-26L
CB112-52L

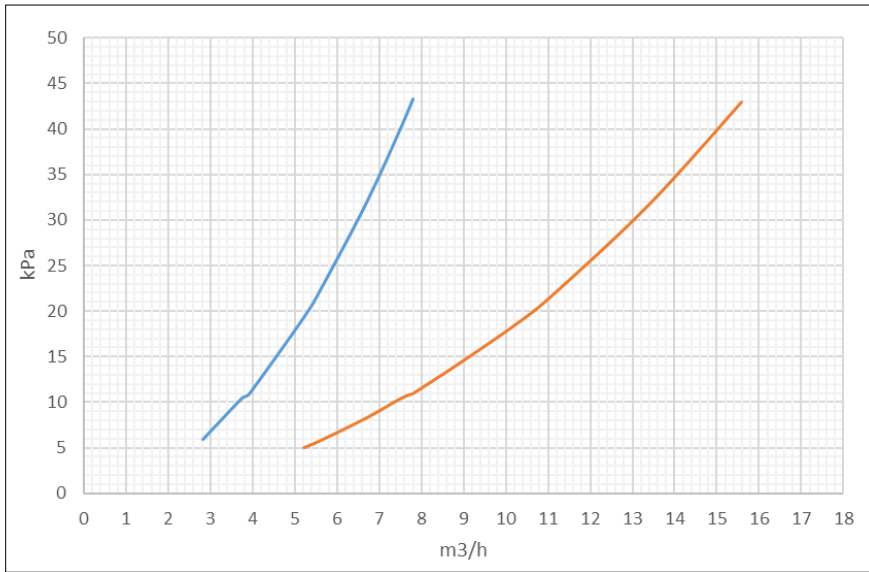

dT20K
CB112-38M
CB112-68M

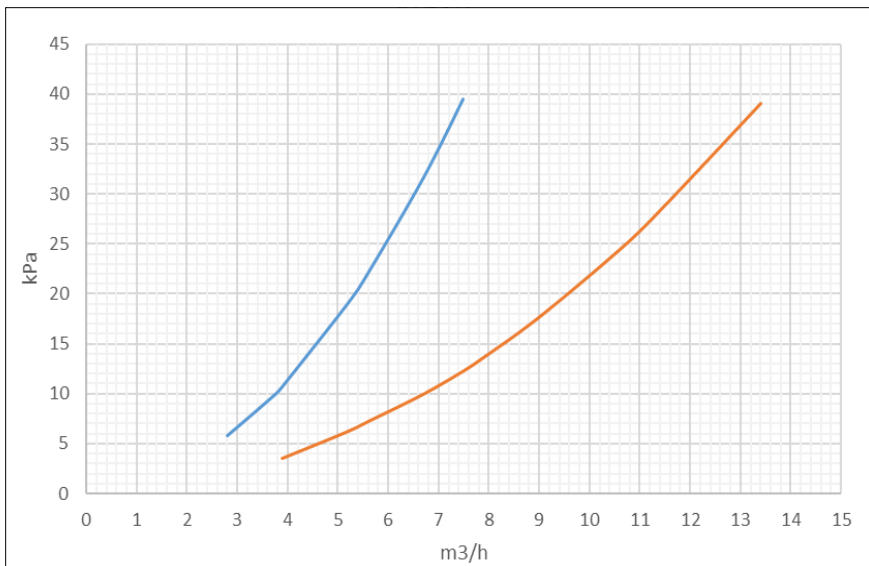

Accessories

Hydraulics Single boiler

Dimensional sketch for Plate heat exchanger kits TLPLUS

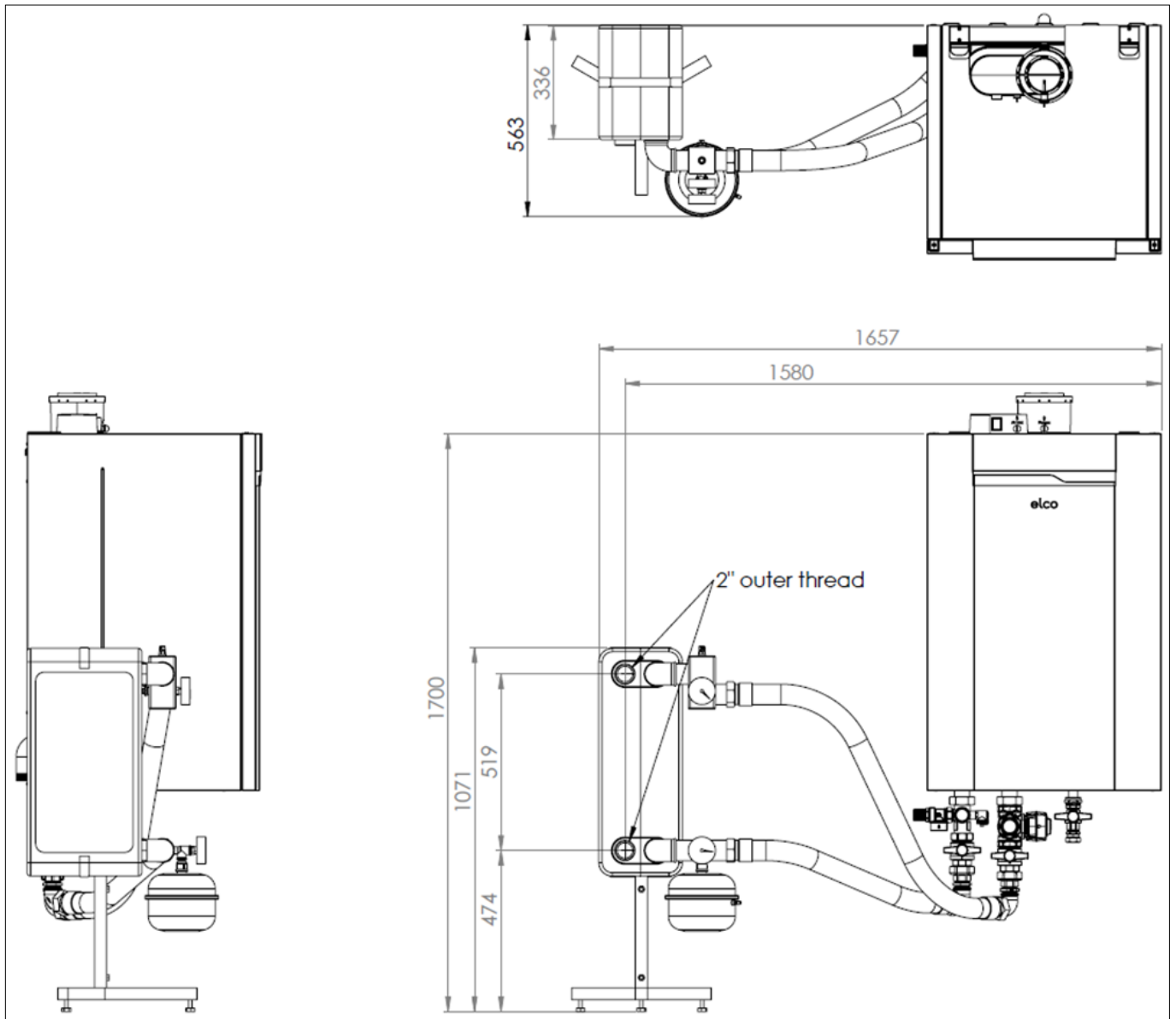



Accessories

Other

	DESCRIPTION	SAP CODE
	AIR FILTER Ø100 60-140KW TH/R L PLUS	3905115
	AIR FILTER Ø130 140-200KW TH/R L PLUS Air filter to prevent impurities from entering the boiler. For models 60-10: Ø200mm H250mm For models 140-200: Ø170mm H290mm	3905116
	FLUE ADAPTER PAR-CONC 100/100-150 TLPLUS For models 60-120 the parallel air/flue-adapter can be replaced by this concentric air/flue adapter to allow the use on concentric flue gas material. Connection size: Ø100/150mm	3905260
	NEUTRALIZATION BOX DN1 INCL. GRANULATE Including 10kg granulate GIALIT-K L x B x H: 320 x 200 x 230 mm Inlet: G1" Outlet: G1" Max heat input: 75kW Max condensate flow: 9l/h	3590027
	NEUTRALIZATION BOX DN2 INCL. GRANULATE Including 30kg granulate GIALIT-K L x B x H: 420 x 300 x 240 mm Inlet: G1" Outlet: G1" Max heat input: 450kW Max condensate flow: 54l/h	12055172
	NEUTRALIZATION BOX DN3 INCL. GRANULATE Including 2x25kg granulate GIALIT-K L x B x H: 640 x 400 x 240 mm Inlet: G1½" Outlet: G1½" Max heat input: 1.500kW Max condensate flow: 180l/h	3732029
	NEUTRALIZATION BOX HN1.5 INCL. GRANULATE Including 25kg granulate GIALIT-K L x B x H: 420 x 300 x 240 mm Inlet: G1" Outlet: G5/8" Max pump head: 6m Max heat input: 280kW Max condensate flow: 34l/h	12055194
	NEUTRALIZATION BOX HN2.5 INCL. GRANULATE Including 2x25kg granulate GIALIT-K L x B x H: 640 x 400 x 240 mm Inlet: G1" Outlet: G1" Max pump head: 3m Max heat input: 540kW Max condensate flow: 65l/h	3732030
	NEUTRALIZATION BOX HN2.7 INCL. GRANULATE Including 2x25kg granulate GIALIT-K L x B x H: 640 x 400 x 320 mm Inlet: G1½" Outlet: G5/8" Max pump head: 4m Max heat input: 750kW Max condensate flow: 90l/h	3732031

Accessories

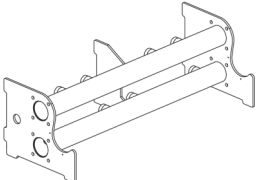
Cascade Frame

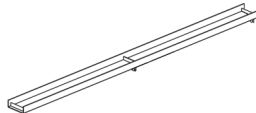
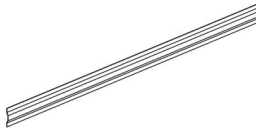
	DESCRIPTION	SAP CODE
	COLLECTOR FLOW/RETURN DN65 2B LINE/4B B2B THLPLUS L = 1.398mm	3905129
	COLLECTOR FLOW/RETURN DN65 3B LINE/6B B2B THLPLUS L = 2.098mm	3905130
	COLLECTOR FLOW/RETURN DN100 2B LINE/4B B2B TLPLUS L = 1.398mm	3905132
	COLLECTOR FLOW/RETURN DN100 3B LINE/6B B2B TLPLUS L = 2.098mm	3905134
	INSULATION COLLECTOR DN65/DN100 1BOILER TLPLUS Insulation set for a flow/return collector tube.	3905136
	CASCADE DEAERATOR TLPLUS	3905137
	CASCADE FRAME FOOT L-SHAPE WH B2B TLPLUS	3905142
	CASCADE FRAME FOOT I-SHAPE WH LINE TLPLUS	3905143
 	CASCADE FRAME SPACER SUPP. WH 2B TLPLUS Spacer kit for top and bottom 2 boilers in line.	3905144
	CASCADE FRAME SPACER SUPP. WH 3B TLPLUS Spacer kit for top and bottom 3 boilers in line.	3905147
	CASCADE MOUNTING BRACKET 2B TLPLUS	3905148
	CASCADE MOUNTING BRACKET 3B TLPLUS	3905149

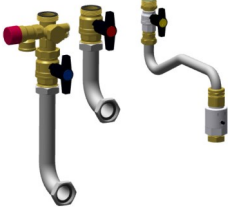
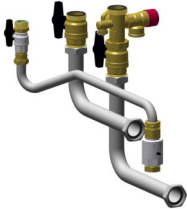
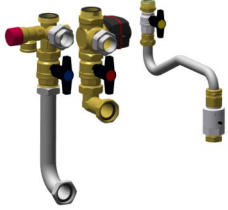
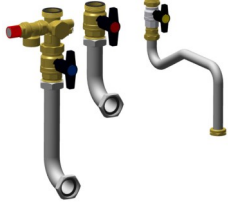
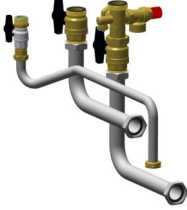
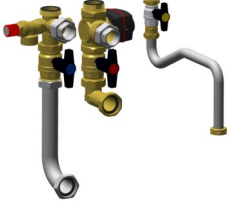

Accessories

Cascade Connection kits

	DESCRIPTION	SAP CODE
	<p>TAE/TAS GAS V. KIT LINE WH CH TH-LPLUS Boiler line cascade connection kit with TAE/TAS gas valve. When the temperature of the TAE/TAS valve body reaches 100°C (for example in case of fire) the valve will shut off the gas supply to the boiler.</p>	3905107
	<p>TAE/TAS GAS V. KIT B2B WH CH TH-LPLUS Boiler back to back cascade connection kit with TAE/TAS gas valve. When the temperature of the TAE/TAS valve body reaches 100°C (for example in case of fire) the valve will shut off the gas supply to the boiler.</p>	3905110
	<p>TAE/TAS GAS V. KIT LINE WH DHW TH-LPLUS Boiler line cascade connection kit with DHW 3-way valve and TAE/TAS gas valve. When the temperature of the TAE/TAS valve body reaches 100°C (for example in case of fire) the valve will shut off the gas supply to the boiler.</p>	3905111
	<p>CASCADE WH FRONT CON. KIT BOILER CH TLPLUS Boiler line cascade connection kit with shut off valves and 6 bar safety valve.</p>	3905152
	<p>CASCADE WH BACK CON. KIT BOILER CH TLPLUS Rear boiler B2B cascade connection kit with shut off valves and 6 bar safety valve.</p>	3905153
	<p>CASCADE WH FRONT CON. KIT BOILER DHW TLPLUS Boiler line cascade connection kit with DHW 3-way valve. Connections system side: DHW: G 1.1/4"</p>	3905154
	INSULATION CASCADE WH CONNECTION KIT TLPLUS	3905167

Accessories

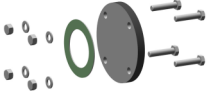
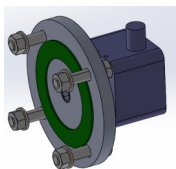
Cascade Gas

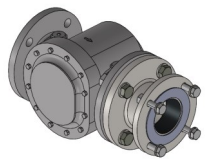
	DESCRIPTION	SAP CODE
	FLANGE KIT DN65 GAS TLPLUS	3905029
	MIN. GAS PRESSURE SWITCH CASCADE TH/R L PLUS The minimum gas pressure switch will interrupt the cascade operation in case the gas supply pressure drops below the set value on the switch. Setting of the switch depends on the used gas type. The switch is fitted on a DN65 flange and comes with bolts and gasket to be fitted on the end of the cascade gas collector.	3905102
	GAS PIPE DN65 DUO Gas pipe DN65 to be used for cascade using the DUO low loss header.	3905131
	CASCADE GAS FILTER DN65 TLPLUS It is recommended to use a gas filter in the gas connection to the cascade to prevent impurities from entering the boilers. The kit contains a gas filter (GF40065/4) and an adapter piece. Connection cascade side: DN65 PN6 Connection system side: DN65 PN16	3905138

Accessories

Cascade Low loss headers

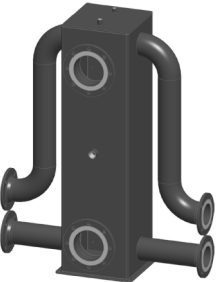
	DESCRIPTION	SAP CODE
	<p>LOW LOSS HEADER DN65 Low loss header suitable up to 452kW. The low loss headers comes standard with adjustable feet, automatic air vent, drain valve, pocket for temperature sensor T10, M16x55 bolts, spring washers and nuts.</p>	3905033
	<p>LOW LOSS HEADER DN100 Low loss header suitable up to 1.000kW. The low loss headers comes standard with adjustable feet, automatic air vent, drain valve, pocket for temperature sensor T10, M16x55 bolts, spring washers and nuts.</p>	3905034
	<p>INSULATION CASCADE LLH DN65 TLPLUS</p>	3905040
	<p>LLH DN100 DUO kit TLPLUS Low loss header suitable up to 1.600kW. The low loss headers comes standard with adjustable feet, automatic air vent, drain valve, pocket for temperature sensor T10, M16x55 bolts, spring washers and nuts.</p>	3905176
	<p>LLH DN100 INSULATION TLPLUS</p>	3905177

Accessories

Cascade Low loss headers

Dimensional sketch for
3905033 LLH DN65

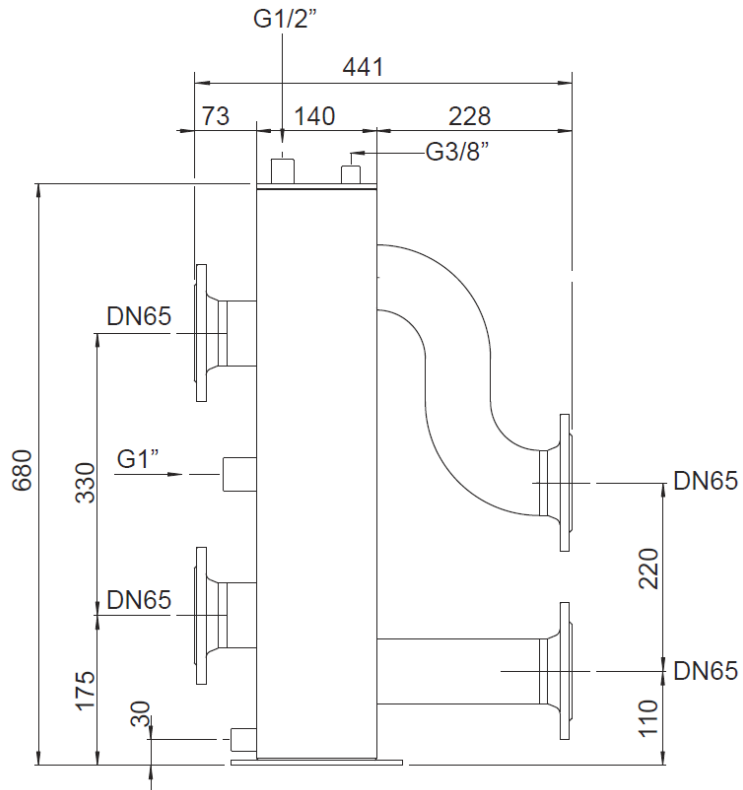

Dimensional sketch for
3905034 LLH DN100

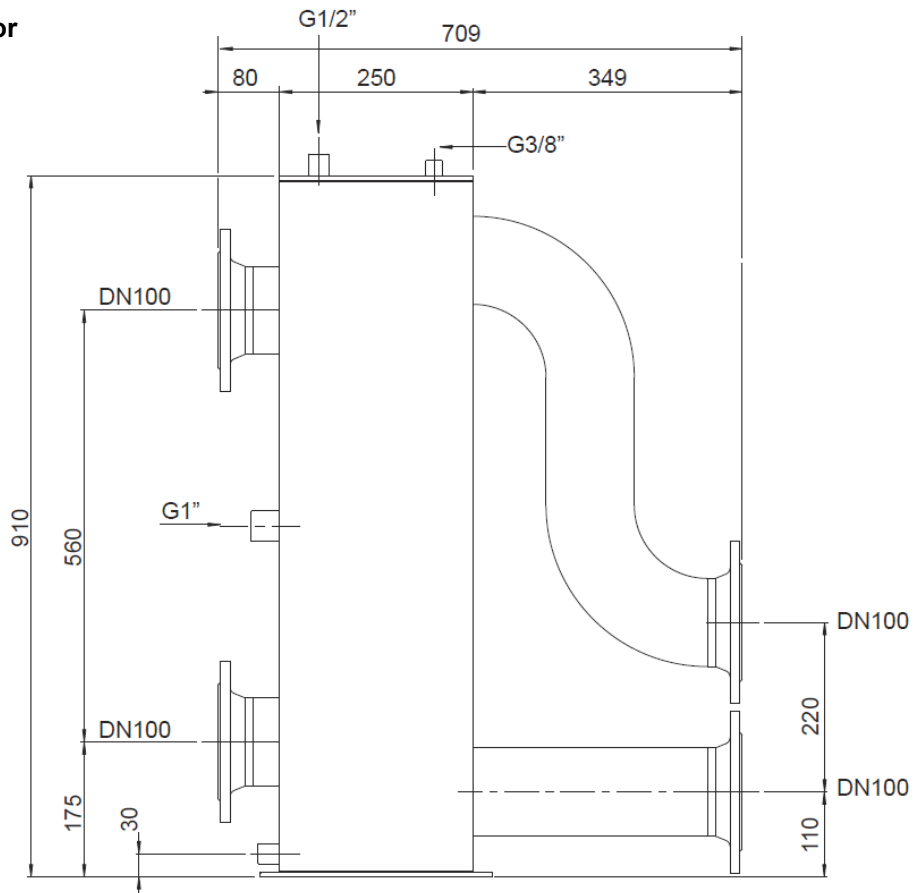

Accessories

Cascade Low loss headers

Dimensional sketch for
3905176 LLH DN100 DUO

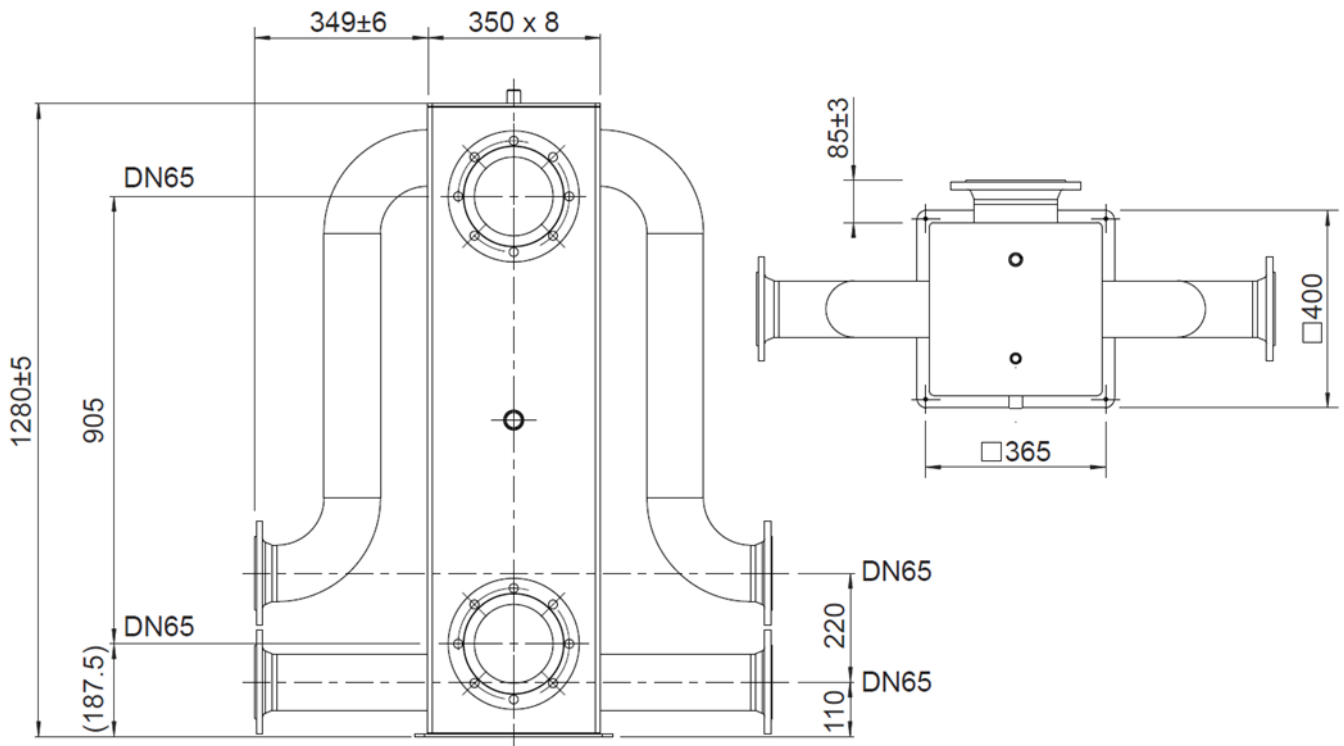

Accessories



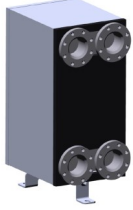
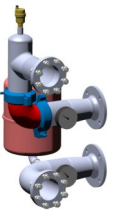

Cascade Plate heat exchangers

	DESCRIPTION	SAP CODE
	CASCADE PLATE HEAT EXCHANGER DT10K WH-FS TLPLUS	3905194
	CASCADE PLATE HEAT EXCHANGER DT15K WH-FS TLPLUS	3905195
	CASCADE PLATE HEAT EXCHANGER DT20K WH-FS TLPLUS Plate heat exchanger kit to separate primary and secondary circuit. Comes with floor standing support and insulation. Suitable up to 465kW.	3905196
	CASCADE PHE CONNECTION KIT DN65	3905197
	CASCADE PHE CONNECTION DN100 Connection kit to connect the plate heat exchanger to the cascade kit. Includes a deaerator, 8L expansion vessel, pressure and temperature gauge.	3905265

Cascade (up to 465kW)			465kW
Primary circuit	dT20K	m3/h	21,04
Expansion vessel		L	8
Secondary circuit	dT20K	header type	B320LTHx206
		SAP code	3905196
		m3/h	21,04
		kPa	4,15
	dT15K	header type	B320LTH+Lx100
		SAP code	3905195
		m3/h	26,65
		kPa	17,3
	dT10K	header type	B320LTH+Lx108
		SAP code	3905194
		m3/h	40,00
		kPa	17,6

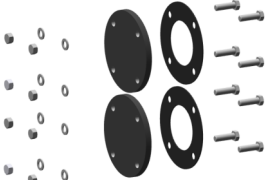
Accessories

Cascade Hydraulics

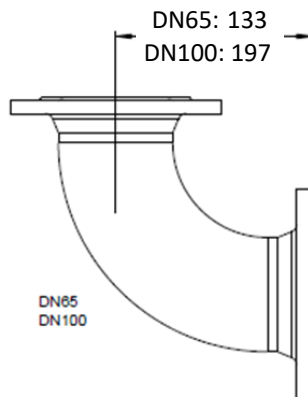

	DESCRIPTION	SAP CODE
	FLANGE KIT DN65 TLPLUS Waterside flange kit containing 2 DN65 flanges, gaskets, bolts, washers and nuts.	3905026
	FLANGE KIT DN100 TLPLUS Waterside flange kit containing 2 DN100 flanges, gaskets, bolts, washers and nuts.	3905027
	CASCADE BEND 90° DN65 TLPLUS Set of 2 pieces 90° bends in DN65 to change the direction of the pipe work.	3905035
	CASCADE BEND 90° DN100 TLPLUS Set of 2 pieces 90° bends in DN100 to change the direction of the pipe work.	3905036
	FLANGE KIT WELDING FLANGES 2XDN100 + DN65 2x DN100 + 1x DN65	3905038
	WELDING FLANGE DN65 WATER + DN65 GAS	3905125
	WELDING FLANGE DN150 WATER + DN65 GAS	3905126
	INSULATION BEND 90° DN65 TLPLUS	3905041
	INSULATION BEND 90° DN100 TLPLUS	3905174

Dimensional sketch for
 3905035 and 3905036
 BEND 90° DN65 + DN100:

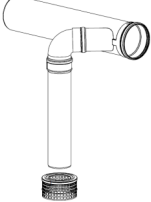
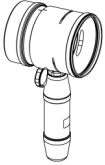

Accessories

Cascade Flue

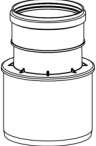
	DESCRIPTION	SAP CODE
	CASCADE FLUE KIT DN150 LINE TLPLUS Flue collector Ø150mm with Ø100mm boiler connector for one boiler.	3905198
	CASCADE FLUE KIT DN200 LINE TLPLUS Flue collector Ø200mm with Ø100mm boiler connector for one boiler.	3905200
	FLUE SIPHON SET DN150 TLPLUS Ø150mm Flue collector end piece with syphon.	3905199
	FLUE SIPHON SET DN200 TLPLUS Ø200mm Flue collector end piece with syphon.	3905201
	CASCADE FLUE KIT DN150 B2B TLPLUS Flue collector Ø150mm with Ø100mm boiler connector for two boilers in B2B arrangement.	3905202
	CASCADE FLUE KIT DN200 B2B TLPLUS Flue collector Ø200mm with Ø100mm boiler connector for two boilers in B2B arrangement.	3905203
	FLUE REDUCER 130-100MM TLPLUS Adapter to reduce the flue connection size from 130mm to 100mm for the models 170 and 200.	3905264

Service:

ELCO United Kingdom
UK - Basildon, Essex, SS15 6SJ

www.elco.net