

## TECHNICAL SUBMISSION

### TRIGON® L PLUS 100 Floor Standing Ultra Low NOx Condensing Boiler

#### General Description:

The TRIGON® L PLUS 100 boiler is one of a range of seven floor standing, stainless steel, fully modulating, ultra-low NOx, gas fired high efficiency condensing boilers, with maximum outputs ranging between 56.9kW to 183.3kW @ 80/60°C ΔT. All TRIGON® L PLUS boilers utilise a pre-mix combustion system, to provide precise gas to air mixing, resulting in extremely low environmental impact.

The TRIGON® L PLUS 100 is tested to the requirement of BS EN 15502, with NOx annual emissions of 22.7.7mg/kWh. The appliance is therefore awarded the maximum two BREEAM credits. The modulation range is from 18.1kW to 90.2kW @ 80/60°C, increasing to 98.8kW when operating in full condensing mode. The boiler is calculated to have a Gross Seasonal Efficiency of 96.2% which meets with the efficiency criteria as set out in the Non-domestic Building Services Guide Compliance Guide 2010 Edition (with 2013 amendments).

The TRIGON® L PLUS boilers are low water content appliance that offer compact dimensions with easy manoeuvrability via their cargo wheels. The boiler includes a comprehensive controller (HMI) that features integrated master-slave cascade functionality. Multiple boilers in a cascade installation can satisfy a large range of heat demands for commercial applications and provide security of service, with the added benefit of increased modulation ranges (turn-downs). There are additional kits to allow control of heating zones and provide hydraulic separation for the primary circuits. Elco Heating Solutions offer the optional communication gateway and this allows communication with building management systems using BACnet, LONworks, MODbus & KNX. Two way communication is possible allowing remedial alterations to be made from a remote location.

The boiler is supplied in one piece, with a fully insulated robust and stylish outer casing fabricated from stove enabled steel sheet, providing low standing heat loss. The boiler includes a primary modulating pump that is controlled to accurately match the flow rate requirement at the boiler heat exchanger, to the modulation rate of the burner. The combustion and primary flow systems include non-return valves for additional security of operation.

The TRIGON® L PLUS boiler can be supplied with an optional backpack solution. This consists of a low loss header, or plate heat exchanger fitted to the rear of the boiler. Elco Heating Solutions also supply a fully integrated package consisting of single, or multiple boilers that offer compact dimensions, ease of installation and peace of mind.



**Compliance with Standards** as appropriate with relevant sections of: Gas Appliance Directive 90/396/EEC & Boiler Efficiency Directive 92/42/EEC.

**Warranty is 10 years parts and labour subject to:**

1. The warranty registration form being fully completed and returned to Elco Heating Solutions within 30 day of delivery; this can also be completed on-line at [www.elco.co.uk](http://www.elco.co.uk)
2. The goods are commissioned within 6 months of purchase by an Elco Heating Solutions engineer.
3. Elco Heating Solutions Limited are engaged to perform an annual service and inspection.

**Or 7 years parts and labour subject to:**

1. The warranty registration form being fully completed and returned to Elco Heating Solutions within 30 day of delivery; this can also be completed on-line at [www.elco.co.uk](http://www.elco.co.uk)
2. The goods are commissioned within 6 months of purchase by an Elco Heating Solutions engineer.
3. Any replacement parts (including serviceable parts required no later than every 2 years in accordance with the Manufacturers Operations and Maintenance manual) used are official Elco spare parts and service kits and are registered with Elco Heating Solutions against the corresponding boiler by emailing the boiler and service kit serial numbers to [service@elco.co.uk](mailto:service@elco.co.uk)

**Or limited to twelve months parts and labour only** from date of delivery if Elco Heating Solutions do not commission the appliance.

## Technical Data:

Boiler Model	TRIGON® L PLUS 100	
Seasonal space heating efficiency class <sup>1</sup>	-	
Nominal heat output at 80/60°C	90.2	kW
Minimum heat output at 80/60°C	18.1	kW
Nominal heat output at 50/30°C	98.8	kW
Minimum heat output at 50/30°C	19.8	kW
Nominal heat input full load Net	92.3	kW
Minimum heat input full load Net	18.5	kW
Efficiency at 80/60°C full load Net/Gross	97.7/88.0	%
Efficiency at 50/30°C min load Net/Gross	107.3/96.7	%
Efficiency at 30°C return 30% load Net/Gross	108.9/98.1	%
Gross seasonal efficiency <sup>2</sup>	96.2	%
Gas consumption max/min nat gas G20	9.77/1.95	m <sup>3</sup> /h
Gas consumption max/min LPG G31 *	7.56/1.51	kg/h
Gas inlet pressure max/min nat gas G20	25/17	mbar
Gas inlet pressure max/min LPG G31 *	57.5-42.5 / 35-25	Mbar
NOx annual emissions (EN 15502) <sup>3</sup>	22.7	mg/kWh
BREEAM Credits <sup>4</sup>	2	-
Flue gas temperature at 80/60°C full load	71	°C
Max permissible flue resistance	243	Pa
Water pressure max/min	6.0/1.0	bar
Maximum temperature set point	90	°C
Water flow at ΔT=20K	1.08	lit/sec
Residual head of pump at ΔT=20K	0	kPa
Water flow at ΔT=25K	0.87	lit/sec
Residual head of pump at ΔT=25K	16.75	kPa
Minimum water flow rate	0.22	lit/sec
Electrical connection	230	V
Electrical power consumption boiler 230V 50Hz Boiler including pump	120	W
Electrical power consumption boiler 230V 50Hz Boiler excluding pump	33	W
Sound Power Level	60.3	dB(A)
Weight (empty)	80	Kg
Water content	13.9	litres
<b>Dimensions</b>		
Water connections flow/return <sup>5</sup>	R2"	-
Gas connection <sup>6</sup>	R1½"	-
Flue gas connection concentric	100/150	mm
Room sealed using separate exhaust and combustion air supply	2 x 100	mm
Condensate connection	35.5	mm
Boiler depth	675	mm
Boiler width	530	mm
Boiler height (excluding connections)	1100	mm

- 1 In accordance with directive 2010/30/EU and regulation (EU) 813/2013
- 2 In accordance with equation 2 in the Non-Domestic Building Services Compliance Guide
- 3 NOx value are calculated on GCV
- 4 BREEAM UK New Construction 2018
- 5 With optional Water/Gas Connection Kit the connection sizes decrease to 1½"
- 6 With optional Water Gas Connection kit the connection size decreases to 1"
- \* LPG models available from 2021

## TRIGON® L PLUS 100 Floor Standing Dimensions & Clearances:

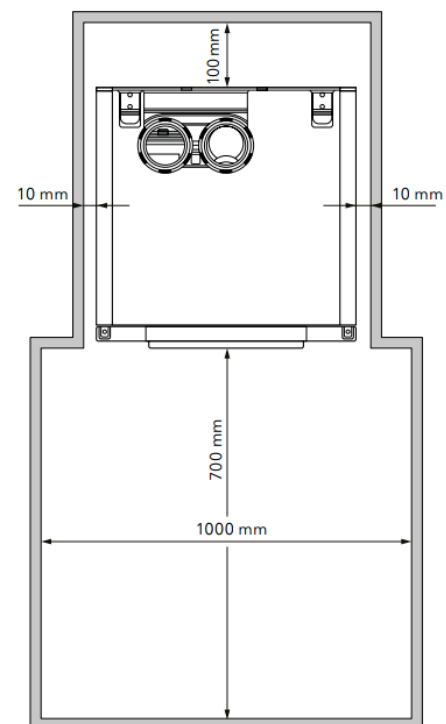
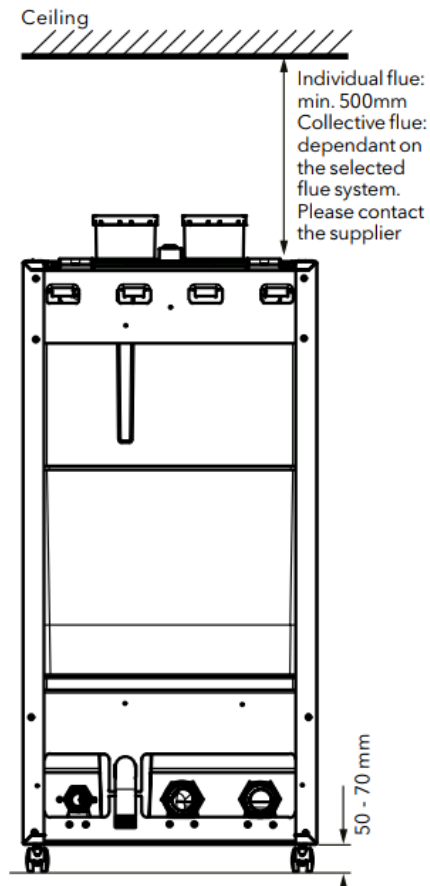
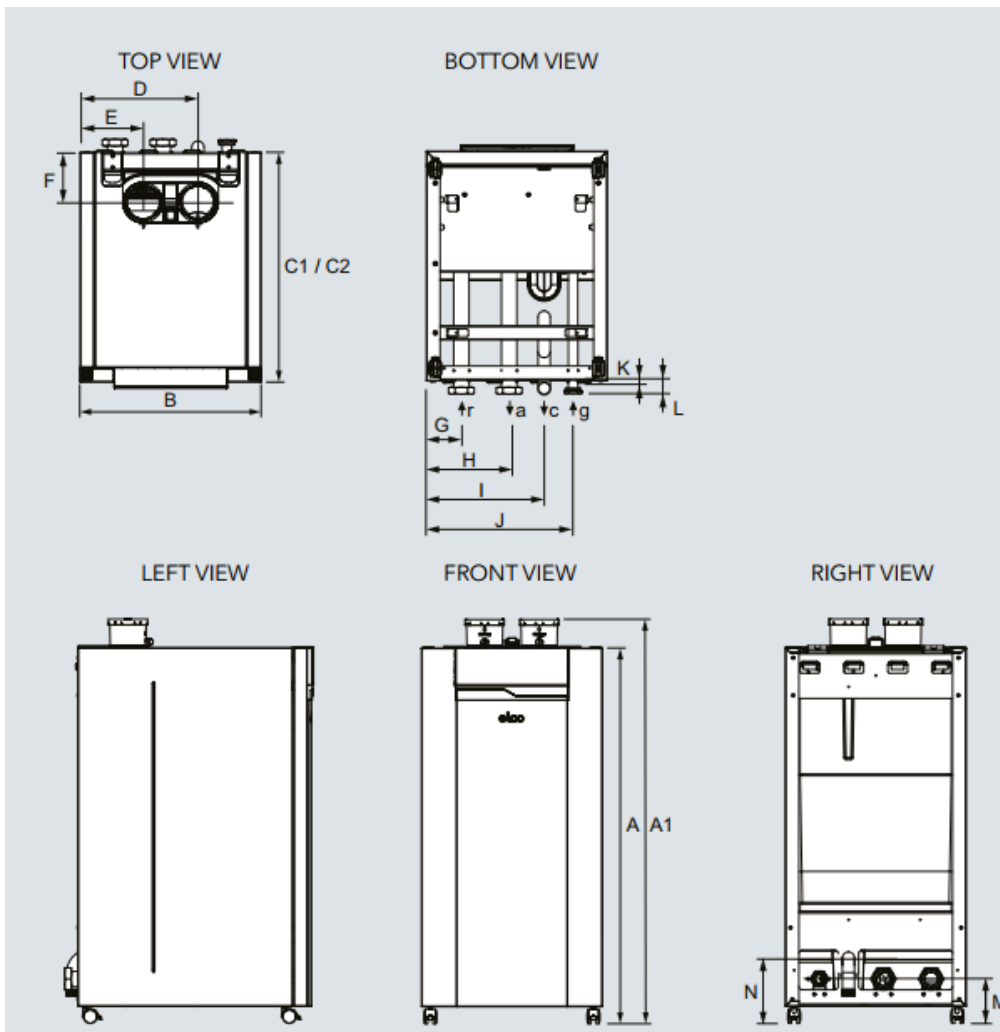

Dimensions		
Boiler height (A)	1100	mm
Boiler height with connections (A1)	1185	mm
Boiler width (B)	530	mm
Boiler depth C1/C2	675	mm
Flue Gas connection (D)	345	mm
Air intake connection (E)	185	mm
Air and flue gas connection (F)	150	mm
Boiler return connection (G)	103	mm
Boiler flow connection (H)	243	mm
Condensate Connection (I)	345	mm
Gas connection (J)	430	mm
Condensate connection (K)	15	mm
Boiler flow and return and gas connection (L)	35	mm
Boiler flow and return and gas connection (M)	130	mm
Condensate connection (N)	190	mm
Condensate connection (c)	35	mm
Parallel connection ( air and flue gas)	2 x 100	mm
Boiler flow (a) Return (r)	2"	-
Gas connection (g)	1¼"	-