

Commercial Hot Water Range  
Direct units: 18 - 540kW  
Indirect units: 180 - 3000L



TECHNICAL INFORMATION

# Commercial Hot Water Range



**69 MODELS**  
within our range

# ELCO Heating Solutions

## Commercial Hot Water Range

ELCO provides both indirect and direct solutions to meet most commercial applications.

### Commercial hot water range

Direct



The **TRIGON® XL Gas Water Heater** is a modulating low NOx condensing appliance incorporating a pre-mix combustion system and a stainless steel heat exchanger, working on Natural Gas or LPG.

There are 3 different designs to choose from including: Standard, Industrial and Swimming Pool, each with 7 different models from 142kW to 540kW.

The Standard and Industrial models can satisfy a continuous DHW delivery of up to 10,563 litres/hour, while the Swimming Pool model offers up to 27,354 litres/hour.

Direct



The **Tudor NHREC Gas Water Heater** is a condensing appliance incorporating a room sealed pre-mix combustion system working on Natural Gas or LPG.

There are 3 different models in the range from 18kW to 61kW with a storage capacity from 213 litres to 350 litres. The Tudor NHREC Water Heaters can satisfy a continuous DHW delivery of up to 1196 litres/hour.

The **Tudor NHREX Gas Water Heater** is a high efficiency atmospheric appliance ideal for refurbishments, working on Natural Gas or LPG.

There are 4 models in the range from 18kW to 52kW, with a storage capacity from 180 litres to 320 litres.

The Tudor NHREX Water Heaters can satisfy a continuous DHW delivery of up to 1007 litres/hour.

Both cylinders are constructed from carbon steel with an enamel lining and incorporate a Protech electronic anode system as standard.

Indirect- Single Coil



The **Inox-Maxi SSC1** is a single coil stainless steel calorifier with 6 models in the range from 44 to 84kW, with a storage capacity from 500 litres to 2000 litres.

The Inox-Maxi SSC 1 calorifiers can satisfy a continuous DHW delivery of up to 1305 litres/hour.

The **Polywarm-Maxi PWC1** is a single coil calorifier constructed from carbon steel with a patented lining with 4 models in the range from 38kW to 82kW, with a storage capacity from 500 litres to 1500 litres.

The Polywarm-Maxi PWC 1 calorifiers can satisfy a continuous DHW delivery of up to 1264 litres/hour.

Indirect- Twin Coil

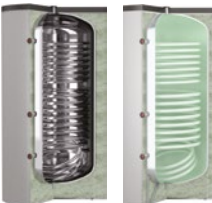

The **Inox-Maxi SSC2** is a twin coil stainless steel calorifier with 6 models in the range from 21 to 122kW, with a storage capacity from 500 litres to 2000 litres.

The Inox-Maxi SSC2 calorifiers can satisfy a continuous DHW delivery of up to 2398 litres/hour.

The **Polywarm-Maxi PWC2** is a twin coil calorifier constructed from carbon steel with a patented lining with 4 models in the range from 18kW to 112kW, with a storage capacity from 500 litres to 1500 litres.

The Polywarm-Maxi PWC2 calorifiers can satisfy a continuous DHW delivery of up to 2113 litres/hour.

Indirect- Tank in Tank



The **Gemini HSCi** is a tank in tank calorifier with the inner DHW cylinder constructed from stainless steel and the outer cylinder constructed from carbon steel.

There are 3 different models in the range from 23kW to 86kW with a storage capacity from 200 litres to 500 litres.

The Gemini HSCi calorifiers can satisfy a continuous DHW delivery of up to 1474 litres/hour.

Hot water Storage



The **Inox-Maxi SSB** is a stainless steel DHW buffer cylinder with 8 models in the range and a storage capacity from 500 litres to 3000 litres.

The **Polywarm-Maxi PWB** is a DHW buffer cylinder constructed from carbon steel with a patented lining, with 7 models in the range and a storage capacity from 500 litres to 3000 litres.

# Contents

## Applications and services

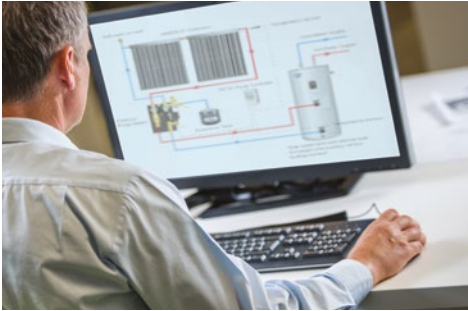

A full range of application engineering and customised solutions for commercial installations.

Plus, ELCO offers complete peace of mind with a range of services, including:

- Maintenance contracts
- Extended warranties
- Start up/Commissioning
- Connectivity
- Service, Repairs & Spares
- System upgrade
- Training on site or at Head Office



**More information:**  
[www.elco.co.uk](http://www.elco.co.uk)



## Get started

**This extensive brochure explains the technology and engineering utilised in ELCO's comprehensive manufacturing processes, as well as the superb features incorporated into each hot water product.**

**From a straightforward replacement, to the most complex commercial system, specifiers can choose the right ELCO product for the application.**

ELCO Heating Solutions	2
DHW Demand Guidance	4
TRIGON® XL Water Heaters	7
Tudor NHREC Water Heaters	15
Tudor NHREX Water Heaters	19
Inox-Maxi SSC1 Calorifiers	23
Polywarm PWC1 Calorifiers	27
Inox-Maxi SSC 2 Calorifiers	31
Polywarm PWC2 Calorifiers	36
Gemini HSCi Calorifiers	41
Inox-Maxi SSB DHW Storage Cylinder	45
Polywarm PWB DHW Storage Cylinder	49
Full range of accessories	53
Studley Castle Case Study	54

# DHW Demand Guidance

**When considering the selection of domestic hot water plant for a specific site, it is important to have a good understanding of the requirements. This information may be supplied in a specification and, if this is the case, the process is simple. Reference to the performance tables for each appliance will provide the necessary guidance.**

There will be occasions where a specification has not been produced and it is therefore necessary to complete an assessment. In this instance, access to historical records for the subject site may be a valuable source for guidance. If the project is a new build and no historical data is available, reference to professional guidance documents is a valuable source of information. The manufacturers of taps, showers and DHW supply outlets will provide guidance on design and maximum flow rates.

This information can be used for guidance.

## What information is required to enable selection of suitable DHW appliance?

We need to consider how much hot water is required and over what period of time. We are therefore looking to make an assessment of the following:

- What is the peak flow rate and at what temperature does the DHW need to be delivered, or stored. Over what period of time would this peak demand occur.
- How often may this peak delivery be repeated during the day.
- What is the average continuous DHW demand during the day.
- With this information, an assessment of the specific demand can be calculated.

## There are different types of DHW appliance and these fall into the following categories

### **Direct:**

The domestic hot water is heated directly at the appliance and the appliance includes a heat generator. The appliance may include a stored volume of DHW.

### **Indirect:**

The heat generator is remote and the heat is transferred to the domestic hot water via a transfer mechanism. This can be a plate heat exchanger or a primary coil in a cylinder.

Two schematics can be found on the next page to show the difference between the Direct and the Indirect.

## There are two mechanisms to meet the demand for delivering domestic hot water to the point of use. These are as follows:

### **Instantaneous**

The domestic hot water is heated as it is being delivered to the point of use.

### **Instantaneous with storage:**

Some of the domestic hot water is generated instantaneously and some is delivered from a stored volume that is held at set-point temperature.

## The specific DHW demand would normally dictate the most suitable method for generating and delivering the DHW.

Instantaneous generation of DHW requires a high heat input and this dictates the size of the heat generator and the size of the fuel supply. If the peak demand is high and we need to meet this demand instantaneously, the capital cost of the plant can be high. The compromise is to provide a stored volume of DHW and hold this at set-point temperature. Where there are high instantaneous demands and this occurs over a relatively short period of time, the demand can be met using the stored volume and the instantaneous DHW generated by the hot water heater. The hotwater heater can be sized to recover the volume of stored DHW over an acceptable period of time.

Guidance on acceptable periods of time for recovery of stored DHW temperatures, relative to specific building types are detailed in technical guidance documents. A good source for reference is BSRIA publication BG 9/2011 Guidelines for building services and the technical guidance detailed in the Chartered Institute of Plumbing and Heating Engineers documents. There may be specific requirements that need to be considered and the selections should accommodate any specific site requirements.

# Installation schematics

## Example of a direct DHW installation

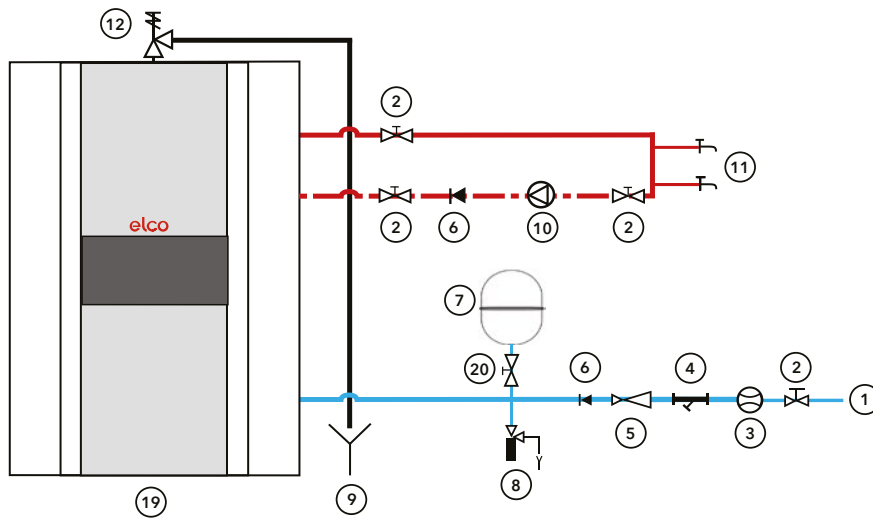

- |                            |                                   |                                           |
|----------------------------|-----------------------------------|-------------------------------------------|
| 1. Cold Water Supply       | 6. Non-Return Valve               | 11. DHW outlets                           |
| 2. Isolation Valve         | 7. Expansion Vessel               | 12. Temperature and Pressure Relief Valve |
| 3. Water Meter             | 8. Expansion Relief Valve         | 19. THISION EVO Water Heater              |
| 4. Strainer                | 9. Drain                          | 20. Lockshield Valve                      |
| 5. Pressure Limiting Valve | 10. Secondary Re-Circulation Pump |                                           |

## Example of an indirect DHW installation

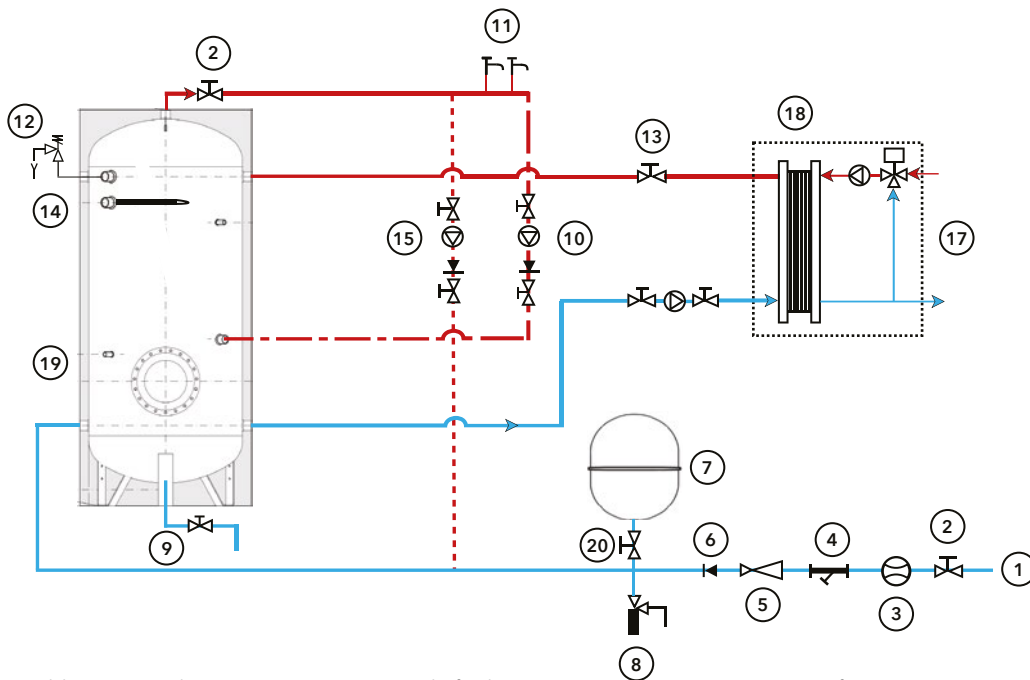

- |                            |                                           |                              |
|----------------------------|-------------------------------------------|------------------------------|
| 1. Cold water supply       | 8. Expansion relief valve                 | 15. De-stratification pump   |
| 2. Isolation valve         | 9. Drain                                  | 17. Primary heat via boiler  |
| 3. Water meter             | 10. Secondary re-circulation pump         | 18. DHW plate heat exchanger |
| 4. Strainer                | 11. DHW outlets                           | 19. DHW storage cylinder     |
| 5. Pressure limiting valve | 12. Temperature and pressure relief valve | 20. Lockshield valve         |
| 6. Non-return valve        | 13. Double regulating valve               |                              |
| 7. Expansion vessel        | 14. Immersion heater                      |                              |

# General DHW Guidance

General guidance on DHW flow rates from specific outlets. Manufacturers specific data should be used where available.

Appliance	60° DHW required	Delivery period	Usage period
Basin	4 litres	1 minute	5 minutes
Bath	75 litres	5 minutes	20 minutes
Kitchen Sink	8 litres	2 minutes	10 minutes
Industrial Sink	22 litres	2.5 minutes	15 minutes
Domestic Shower	23 litres	5 minutes	5 minutes
Industrial Shower	39 litres	5 minutes	5 minutes
Washing Machine	50 litres	2x3 minutes	30 minutes
Dishwasher	16 litres	2x3 minutes	30 minutes
½" Open Tap	9 litres/min	Continuous	?
¾" Open Tap	18 litres/min	Continuous	?

Guidance on DHW use and minimum recommended storage volumes are detailed in the table below. It is recommended that the hot water heater should be sized to raise the temperature of the stored volume from ten centigrade, to the set-point temperature within two hours. The minimum recommended temperature for stored DHW is sixty centigrade.

Type of property	Maximum daily hot water consumption Litres/person	Minimum recommended DHW storage Litres
Offices with canteen	15	5/person
Offices without canteen	10	5/person
Two Star Hotels	114	35/bedroom
Five Star Hotels	136	45/bedroom
District General Hospitals	200	50/bed
Surgical Wards	110	
Medical Wards	110	
Paediatric Wards	125	
Geriatric Wards	70	
Primary Schools	15	5/pupil
Secondary Schools	15	5/pupil
Colleges	15	5/pupil
Boarding Schools	115	25/pupil
Factories with Canteen	15	5/person
Factories without Canteen	10	5/person
Restaurants	6	6/cover
Sports Halls	20	20/person
Swimming Pools	20	20/person
Field Sports Facilities	35	35/person

Extract from BSRIA Rules of Thumb Guidelines for Building Services (5th Edition)

# TRIGON<sup>®</sup> XL



- Stainless steel heat exchanger
- 3 different models to choose from: Standard, Industrial and Swimming pool
- Lightweight construction
- Compact dimensions
- Intelligent control
- Extremely low emissions and high efficiency
- Gross thermal efficiency up to 98.2%
- Output from 142 to 540 kW
- Continuous DHW delivery up to 10,563 litres/hour (Standard and Industrial models) and up to 27,354 litres/hour (Swimming pool model)
- Lifetime high efficiency up to 99% GCV

# TRIGON<sup>®</sup> XL WH – Flexible for every a

## A new standard

The TRIGON<sup>®</sup> XL WH represents a significant step forward in heating technology, with continuous delivery of up to 10,563 litres/hour for the Standard and Industrial models and up to 27,354 litres/hour for the Swimming pool model. With extremely flexible configurations, clever design and a range of models available, this water heater is perfect for a variety of commercial applications, such as health clubs, manufacturing plants and commercial laundrettes.



## Comprehensive control features

A clear text display with integrated master-slave cascade functionality (up to 8 water heaters) makes commissioning simple. Plus, upgradable module capacity provides straightforward connections to a solar system or external heat source.

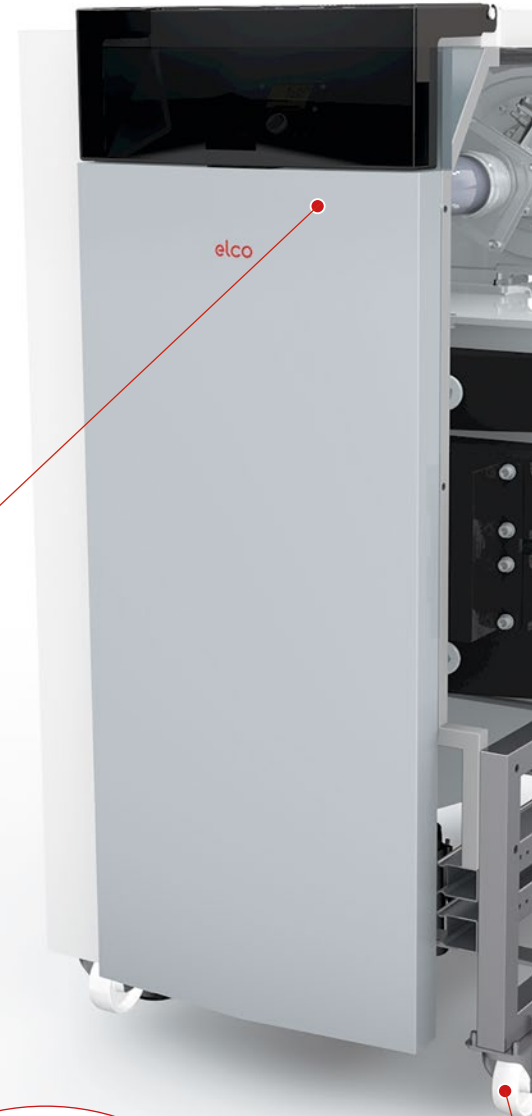

## Wider applications

With an 8 bar max. working pressure, the water heater is compatible with higher buildings without the need for hydraulic system separation.

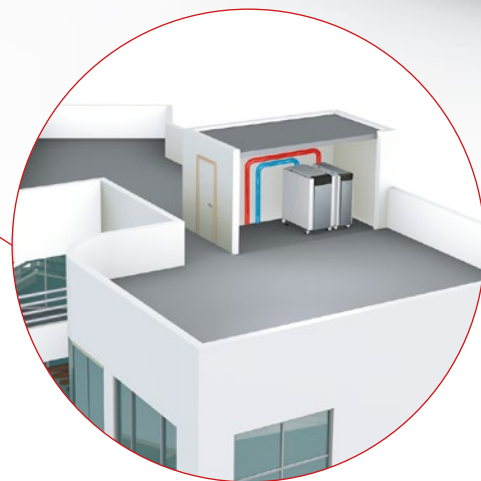

## Lightweight construction

By utilising low water content technology, the water heater can be easily installed on a rooftop - while also delivering superb response times and reduced running costs.



# Application

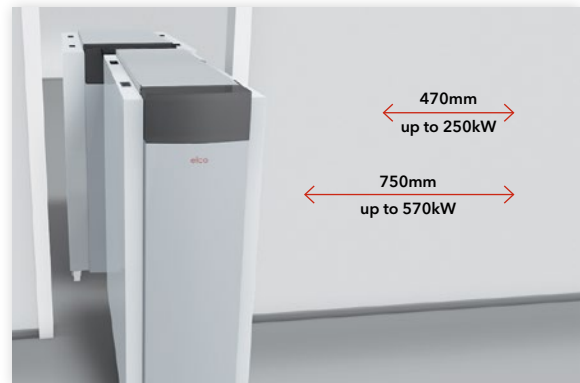
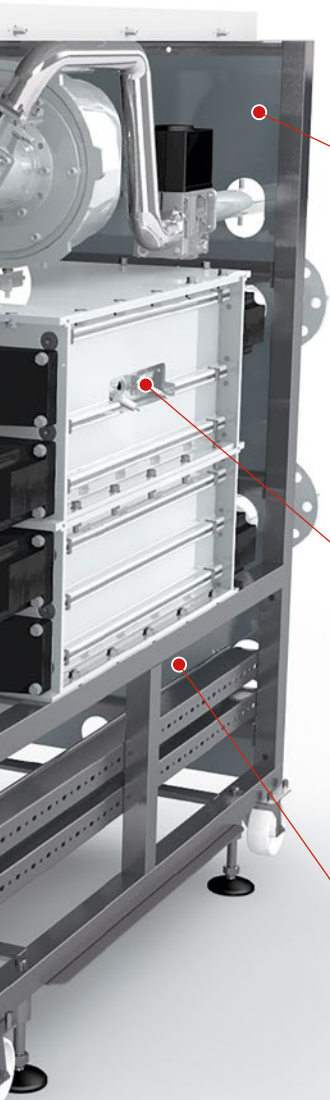

### Compact dimensions

All models are designed to pass through standard 760mm wide doors. The range comprises 21 models with 2 widths.



### Flexible configurations

The inspection glass and ignition electrode can be fitted on either side of the water heater, allowing a more flexible boiler positioning on site.



### Easy transportation

The water heater is supplied with cargo wheels, allowing it to be easily manoeuvred on site. After positioning, the unit can be levelled and lifted from its cargo wheels by adjusting the feet.

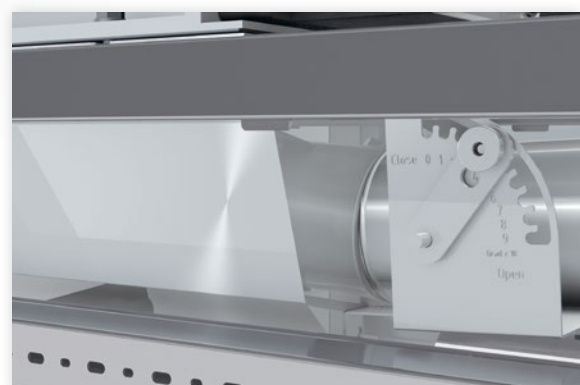

### Simple commissioning

An integrated flue gas damper and rear flue connection provide an installer-friendly arrangement.

# TRIGON<sup>®</sup> XL WH – Designed for challenge

## The burner

TRIGON<sup>®</sup> XL WH has an advanced burner design, which ensures this water heater is the most technologically advanced and best performing unit on the market.

The appliance can operate with a room sealed combustion system, with the provision to duct the combustion air from outside the building, directly to the appliance casing.

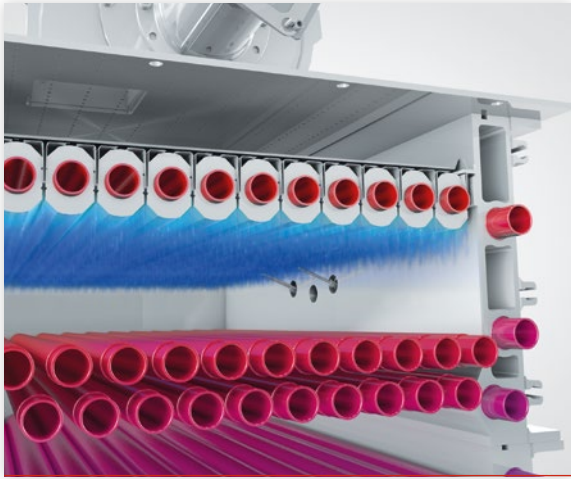

## Unique premix-burner system

A fully modulating, water-cooled cold flame burner utilises a proven and innovative combustion system to provide reliable and robust performance.

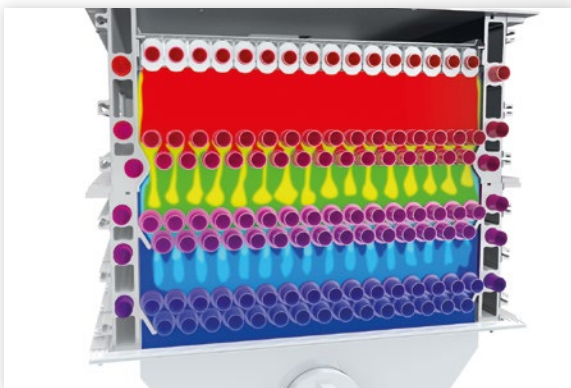

## Low emissions

The water-cooled cold flame burner and the optimised combustion zone achieve extremely low NOx and CO emissions.

\* Standard TRIGON XL IP models only

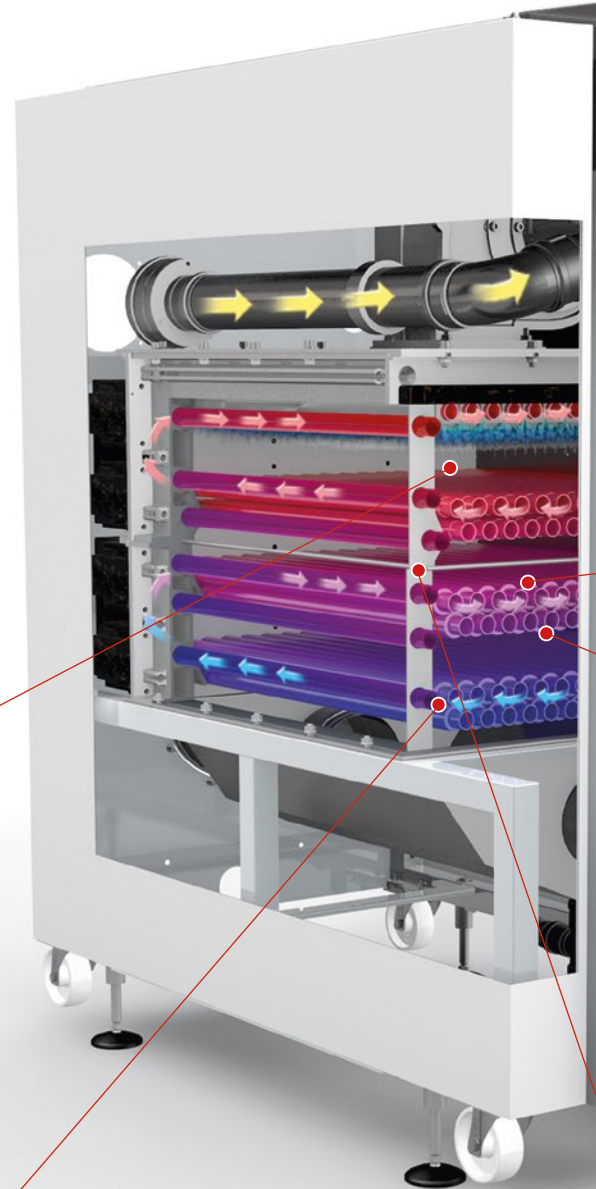

# enging environments

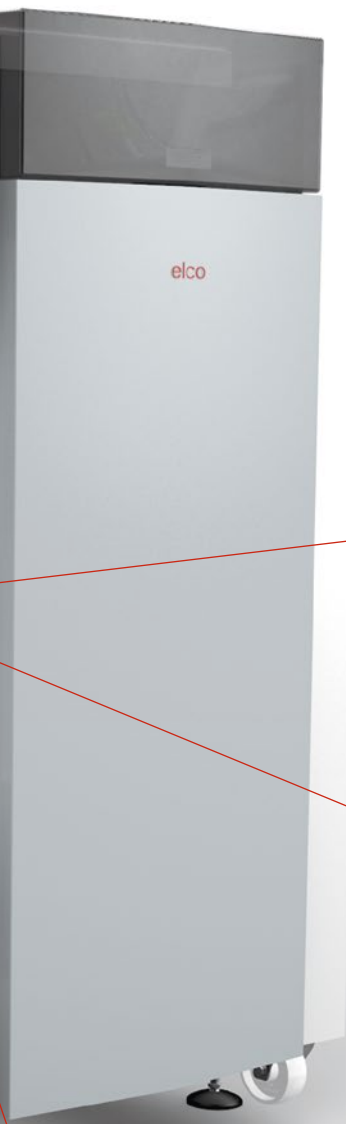

## The heat exchanger

**TRIGON® XL WH** has a stainless steel heat exchanger built for challenging working conditions. It is specifically designed for optimised efficiency and performance during its entire lifetime.

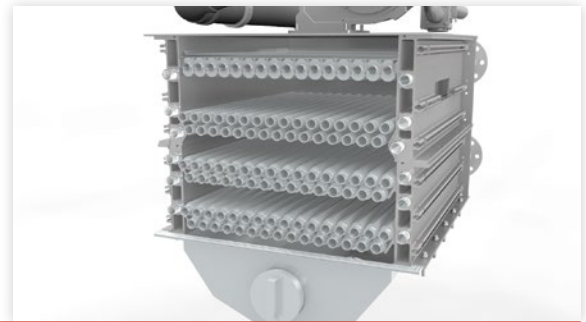

## Lifetime high efficiency

By combining the unique premix-burner/heat exchanger system with the optimised controls, TRIGON® XL WH provides impressive lifetime high efficiencies of up to 99% GCV.

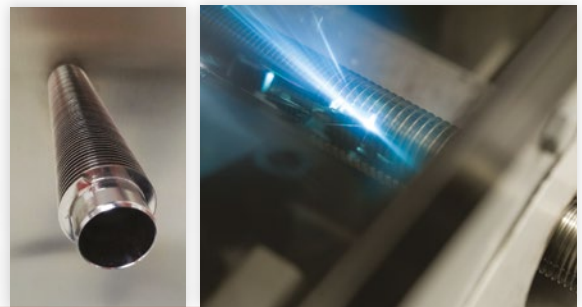

## Stainless steel laser welded fin tube

Advanced robot laser welding technology ensures superb heat transfer between the fins and the tube.

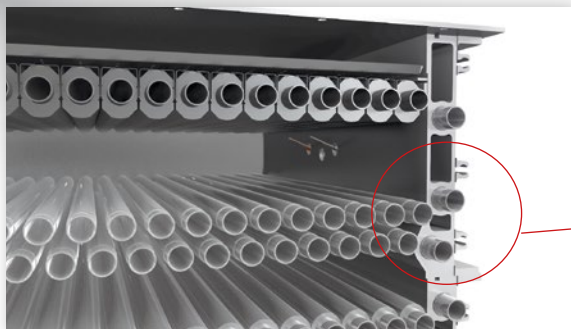

## Water cooled combustion chamber

A carefully engineered hydroforming process fixes the cooling tubes inside the sidewalls, providing the highest possible thermal conductivity.

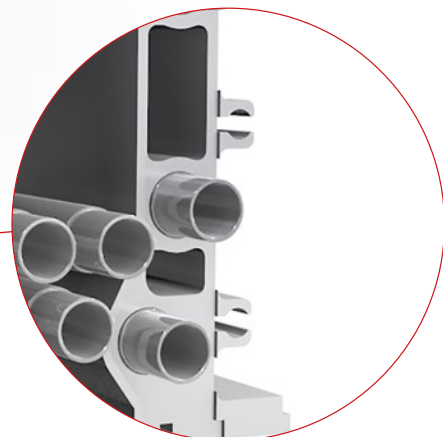

# Technical data - TRIGON® XL WH

TRIGON® XL WH STANDARD (IP)		150	200	250	300	400	500	570	
Water	Continuous delivery @ 44°C ΔT	litres/hour	2782	3723	4646	5586	7456	9321	10563
	First hour delivery @ 44°C ΔT	litres	Continuous delivery litres/hour @ 44°C ΔT plus stored volume						
	Continuous delivery @ 50°C ΔT	litres/hour	2448	3276	4088	4916	6561	8203	9295
	First hour delivery @ 50°C ΔT	litres	Continuous delivery litres/hour @ 50°C ΔT plus stored volume						
	Continuous delivery @ 56°C ΔT	litres/hour	2186	2925	3650	4389	5858	7324	8299
	First hour delivery @ 56°C ΔT	litres	Continuous delivery litres/hour @ 56°C ΔT plus stored volume						
	Set-point temperature (maximum)	°C	65	65	65	65	65	65	65
	TRIGON® XL WH INDUSTRIAL (IND)		150	200	250	300	400	500	570
	Continuous delivery @ 44°C ΔT	litres/hour	2782	3723	4646	5586	7456	9321	10563
	First hour delivery @ 44°C ΔT	litres	Continuous delivery litres/hour @ 44°C ΔT plus stored volume						
	Continuous delivery @ 50°C ΔT	litres/hour	2448	3276	4088	4916	6561	8203	9295
	First hour delivery @ 50°C ΔT	litres	Continuous delivery litres/hour @ 50°C ΔT plus stored volume						
	Continuous delivery @ 80°C ΔT	litres/hour	1531	2048	2556	3074	4102	5129	5812
	First hour delivery @ 80°C ΔT	litres	Continuous delivery litres/hour @ 56°C ΔT plus stored volume						
Set-point temperature (maximum)	°C	90	90	90	90	90	90	90	
TRIGON® XL WH SWIMMING POOL (ZW)		150	200	250	300	400	500	570	
Continuous delivery @ 17°C ΔT	litres/hour	7203	9641	12031	14467	19307	24138	27354	
Continuous delivery @ 19°C ΔT	litres/hour	6447	8626	10764	12944	17275	21597	24474	
Continuous delivery @ 35°C ΔT	litres/hour	3499	4682	5843	7026	9378	11724	13286	
Set-point temperature (maximum)	°C	45	45	45	45	45	45	45	
Energy	TRIGON XL WH IP, IND & ZW		150	200	250	300	400	500	570
	This data is valid for all models.								
	Water heater operating pressure (min/max)	bar	1/8	1/8	1/8	1/8	1/8	1/8	1/8
	Standby losses (constant temp 50°C)	%	98.1	98.1	98.1	98.1	98.2	97.8	98.2
Standby losses (constant temp 50°C)	kW/24hr	0.2	0.2	0.2	0.3	0.3	0.3	0.3	
Natural Gas	Gross input Nominal	kW	161	215	269	323	431	538	611
	Net input - maximum	kW	145	194	242	291	388	485	550
	Output to water (min/max)	kW	31.3/142.3	42.0/190.4	47.0/237.6	56.5/285.7	75.2/381.3	94.6/476.7	120.0/540.2
	Gas inlet pressure (min/max)	mbar	20/50	20/50	20/50	20/50	20/50	20/50	20/50
LPG	Gas flow rate @ 1013mbar & 15°C (min/max)	m³/h	3.0/13.0	4.0/17.8	4.4/22.2	5.3/26.7	7.1/35.6	8.9/44.5	11.2/50.5
	LPG inlet pressure (min/max)	mbar	30/50	30/50	30/50	30/50	30/50	30/50	30/50
	LPG flow rate @ 1013mbar & 15°C	kg/h	2.5/11.3	3.4/15.2	3.8/18.9	4.5/22.7	6.1/30.3	7.6/37.9	9.5/43.0
Flue	Approximate flue gas volume (min/max)	m³/h	43/188	57/251	64/313	77/377	102/502	128/628	161/712
	Flue gas temperature (min/max)	°C	31/75	31/75	31/75	31/75	31/75	31/75	31/75
	NOx emissions (BS EN 15502)	mg/kWh	25.2	25	24.3	24.3	23.7	26.1	27.8
Electrical	Recommended electrical protection	Amps	16	16	16	16	16	16	16
	Run current boiler only (min/max)	Amps	0.21/0.77	0.21/1.16	0.23/1.24	0.21/1.0	0.23/2.19	0.28/2.7	0.27/2.9
	Electrical supply boiler only	V/Hz	230/50	230/50	230/50	230/50	230/50	230/50	230/50
	Voltage tolerance Volts/Hz	%	+10-6/+-1						
Misc.	Sound power	dB(A)	70.3	70.3	70.3	70.3	77.3	77.3	77.3
	Weight empty/full	kg	290/316	332/363	366/399	434/494	496/564	540/615	595/677
	Approximate shipping weight	kg	315	347	381	449	511	555	610

**Note:** The TRIGON® XL Water Heater is not an instantaneous DHW generator and is designed to operate in conjunction with storage only.

# Technical data - TRIGON® XL WH

## TRIGON® XL WH 150, 200 & 250

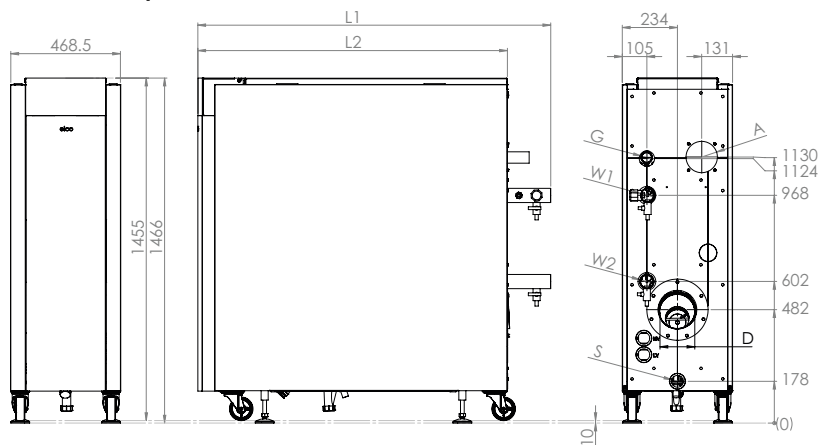

## TRIGON® XL WH 300, 400, 500 & 570

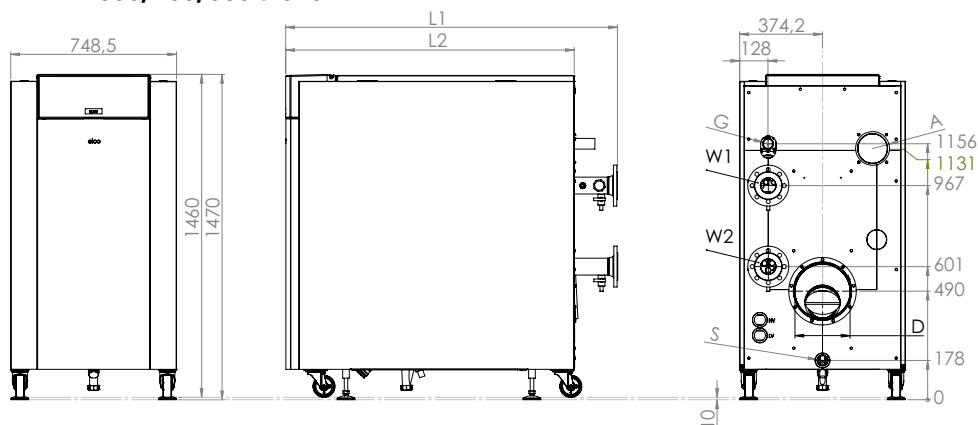

### DIMENSIONS

Water connections (W1/W2)	-	R2"	R2"	R2"	DN65 PN16	DN65 PN16	DN65 PN16	DN65 PN16
Gas connection (G)	-	R1½"	R1½"	R1½"	R1½"	R1½"	R2"	R2"
Flue gas connection (D)	mm	150	150	200	200	250	250	250
Air intake connection (A) (for room sealed use)	mm	130	130	130	130	130	150	150
Condensate connection (S)	mm	32	32	32	32	32	32	32
Boiler length with water connection (L1)	mm	1349	1499	1649	1348	1496	1646	1769
Boiler length without water connection (L2)	mm	1165	1315	1465	1152	1302	1452	1602

### Clearances

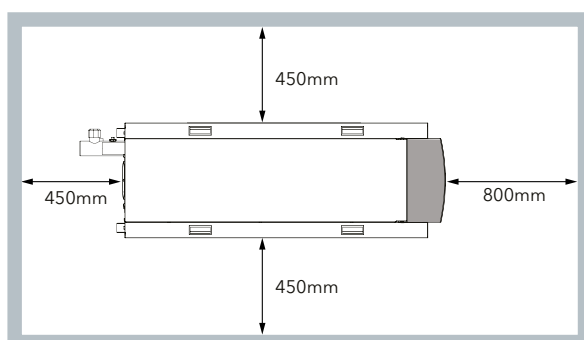

# Examples of hydraulic schemes - TRIGON® XL WH

## TRIGON® XL IND Water Heater cascade with 2 buffer vessels example schematic

This system is mainly used in industrial processes, where there is a requirement for direct increase of the water temperature with more than 17k, without having a constant demand.

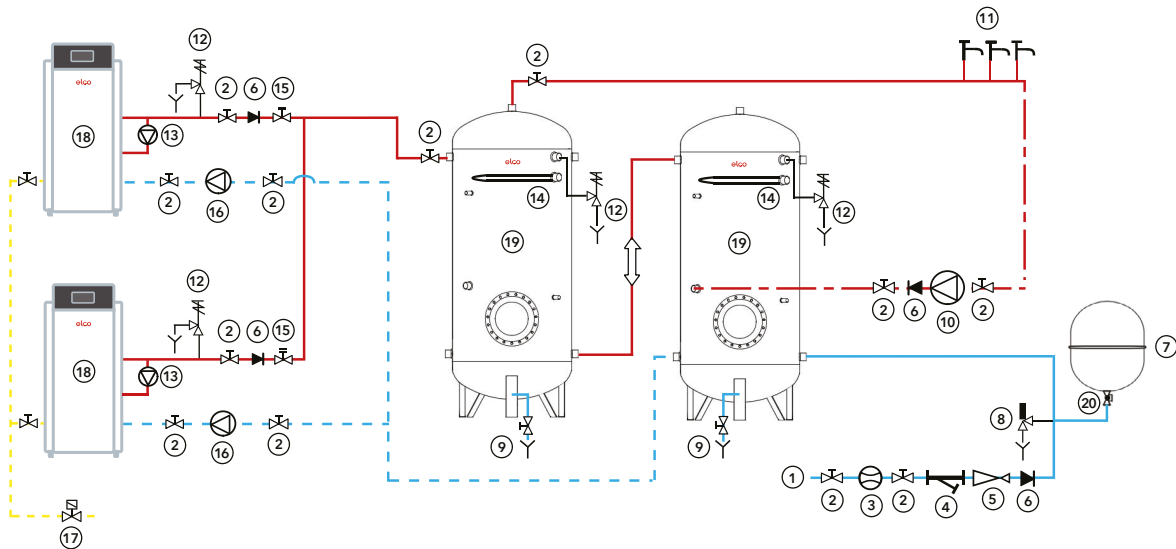

## TRIGON® XL IP Water Heater with DHW storage cylinder schematic example

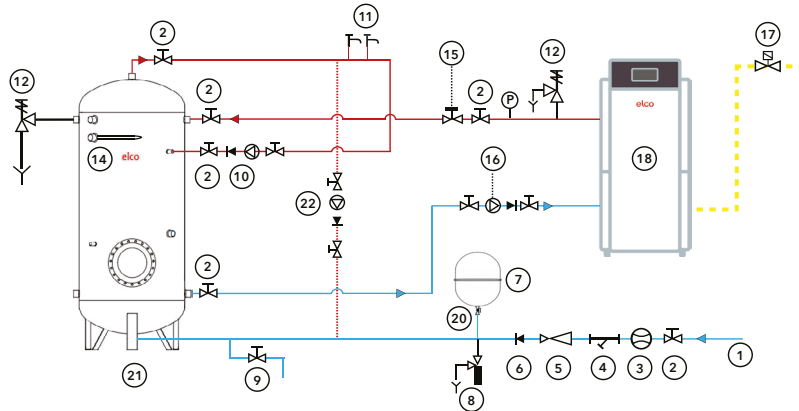

1. Cold water supply
2. Isolation valve
3. Water meter
4. Strainer
5. Pressure limiting valve
6. Non-return valve
7. Expansion vessel
8. Expansion relief valve
9. Drain
10. DHW secondary re-circulation pump
11. Hot water outlets
12. Temperature and pressure relief valve
13. Bypass pump
14. Immersion heater
15. Double regulating valve
16. DHW primary circulation pump
17. Gas shut-off valve
18. TRIGON® XL Water Heater
19. SSB buffer vessel
20. Lockshield valve
21. Inox-Maxi SSB or Polywarm PWB DHW storage cylinder
22. De-stratification pump
23. Swimming pool
24. Filtering kit
25. Water heater circulating pump
26. Swimming pool re-circulation pump
27. Regulating valve
28. Trigon XL ZW Water Heater
29. Pressure relief valve

## TRIGON® XL ZW Swimming Pool Water Heater schematic example

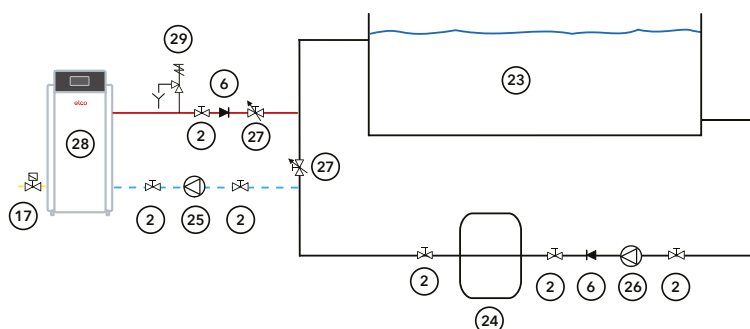

These illustrations are designed to provide general guidance on the hydraulic scheme and should not be considered as an installation drawing.

# Tudor NHREC

**100%**  
**LIKE FOR LIKE**  
**REPLACEMENT**  
(water & gas  
intake & outlet)  
with NHREV



- Condensing unit ideal for new build
- Extremely low emissions and low noise

- Energy efficiency class: A
- Gross thermal efficiency up to 96%

- Output 18 to 61 kW
- Up to 350 litres storage capacity
- Continuous DHW delivery of 1196 litres/hour

# Tudor NHREC – Perfect for medium to large commercial applications

## High efficiency appliance

Utilising the condensing feature of the appliance provides a highly efficient unit.

## Low NOx emissions

Due to the design of the burner and coil, the unit has a low NOx rating.

## Unique serpentine heat exchanger

Designed to provide condensation for the flue gas products and to maximise the efficiency of the heat transfer.

## Secondary re-circulation

The unit has been designed to allow for secondary DHW re-circulation to reduce losses and improve efficiency

## Inspection hatch

Easy access to the base of the cylinder through the inspection hatch for yearly maintenance.

## Compact clearances

Only 500mm clearance required on top of the unit due to the construction of the magnesium anodes comprising 3 segments.

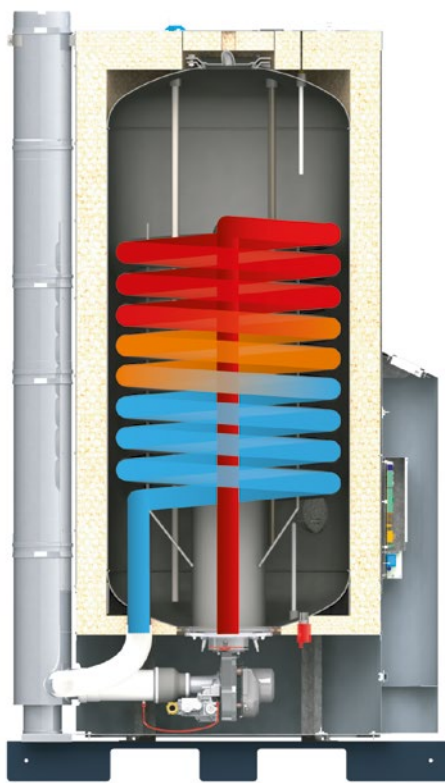

## Excellent DHW delivery

Due to the fast heating burner design the unit is able to provide a fast recovery period.

## Dual cylinder protection

Protection of the cylinder via the electrical PRO Tech Anode System and the Magnesium Anodes factory fitted as standard.

## Extensive integral controls

Control interface provides simple access to programming functions such as integral time control, frost protection and Anti-Legionella sterilization process.

## Easy to maintain

Designed with the contractor in mind, the burner is easily removable for yearly inspection and maintenance.

## Easy to transport

Specialist designed metal base made with the contractor in mind for ease of transport throughout site. Easily removable with just a few bolts.

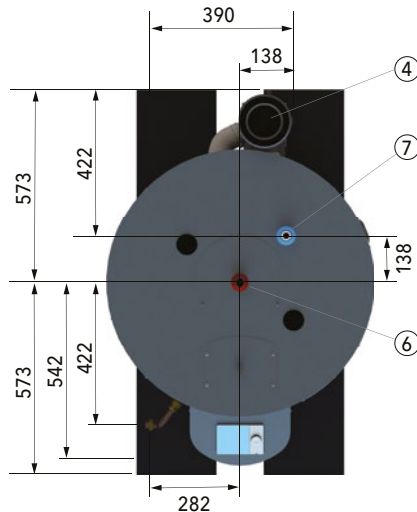
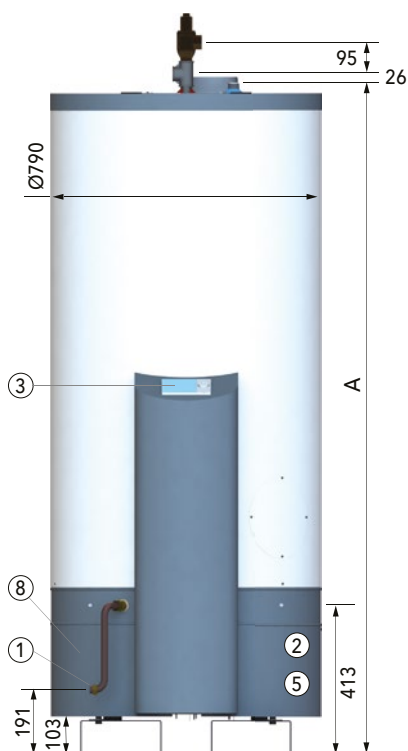

Item No.	Description
1	Gas Inlet 3/4"
2	Pre-mix combustion system
3	LCD control interface
4	Stainless steel concentric flue 100/150
5	2 magnesium anodes 3/4"
6	Hot water outlet 1"
7	Cold water outlet 1"
8	Drain 3/4"

Tudor NHREC	20	40	65
A (mm)	1396	1711	1968



# Technical data – Tudor NHREC

Tudor NHREC		20	40	65	
<b>Performance</b>	Storage capacity	litres	213	269	350
	Continuous delivery @ 44°C ΔT	litres/hour	362	733	1196
	First hour delivery @ 44°C ΔT	litres	575	1002	1546
	Continuous delivery @ 50°C ΔT	litres/hour	319	645	1052
	First hour delivery @ 50°C ΔT	litres	532	914	1402
	Continuous delivery @ 56°C ΔT	litres/hour	284	576	939
	First hour delivery @ 56°C ΔT	litres	497	845	1289
	Operating pressure secondary (min/max)	bar	1/7	1/7	1/7
	Erp load profile		XXL	XXL	XXL
<b>Energy</b>	Gross thermal efficiency	%	91.6	92.5	96
	Erp efficiency class		A	A	A
	Storage recovery time ΔT 44°C	minutes	36	22	18
	Storage recovery time ΔT 50°C	minutes	40	25	20
	Storage recovery time ΔT 56°C	minutes	45	28	23
	Standby losses	kW/24hr	4	4	4
<b>Natural Gas</b>	Gross input - maximum	kW	20.2	40.5	63.7
	Net input - maximum	kW	18.2	36.5	57.4
	Output to water - maximum	kW	18.55	37.51	61.2
	Gas inlet pressure - nominal	mbar	20	20	20
	Gas flow rate @ 1013mbar & 15°C	m³/h	1.9	3.72	6.2
<b>LPG</b>	LPG inlet pressure - nominal (mjin/max)	mbar	31/37	31/37	31/37
	LPG flow rate @ 1013mbar & 15°C	kg/h	1.5	2.8	4.6
<b>Flue</b>	Approximate flue gas volume (maximum output)	m³/h	32.4	64.8	104.4
	Flue gas temperature (maximum output)	°C	52	53	60
	NOx emissions (BS EN 15502)	mg/kWh	21.2	54.1	49
<b>Electrical</b>	Recommended electrical protection	Amps	5	5	5
	Full load run current	Amps	0.5	0.6	1.1
	Electrical supply	V/Hz	230/50	230/50	230/50
	Voltage tolerance Volts/Hz	%V/%Hz		+10-6/+-1	
	PROtech anode included	yes/no	yes	yes	yes
<b>Misc</b>	Sound power (Lwa) indoors	dB(A)	57	57	57
	Number of anodes		2	2	2
	Weight empty/full	kg	169/371	244/513	280/660
	Approximate shipping weight	kg	184	259	295

**Note:** Tudor NHREC can be either Natural Gas or LPG

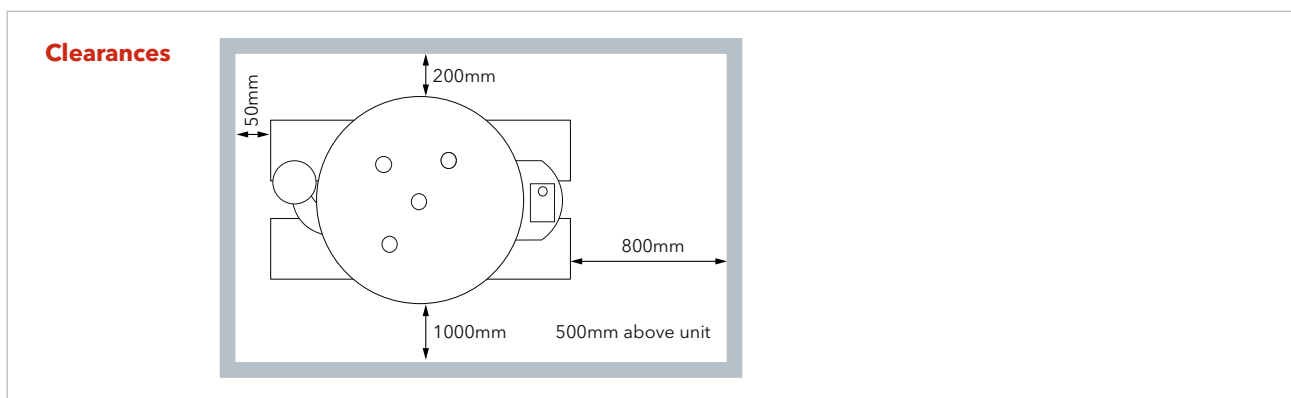

# Examples of hydraulic schemes - Tudor NHREC

## Typical NHREC unvented installation schematic

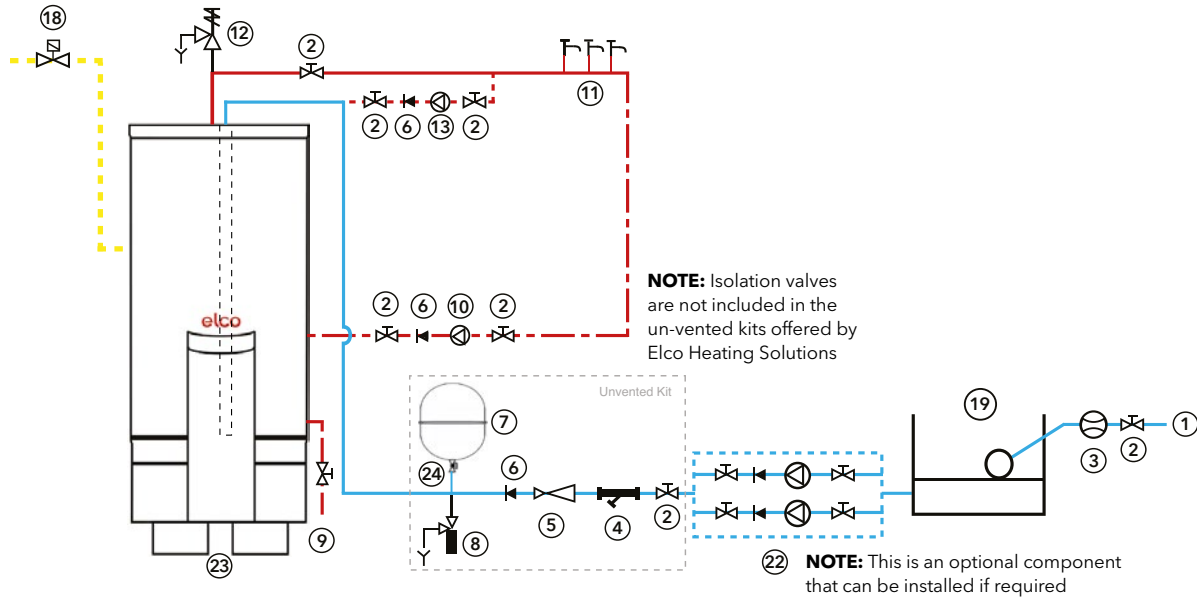

- |                            |                                           |                                                                                                    |
|----------------------------|-------------------------------------------|----------------------------------------------------------------------------------------------------|
| 1. Cold water supply       | 9. Drain                                  | 21. Open vent pipe                                                                                 |
| 2. Isolation valve         | 10. DHW secondary re-circulation pump     | 22. Cold water booster pump set<br>This is an optional component that can be installed if required |
| 3. Water meter             | 11. Hot water outlets                     | 23. NHREC water heater                                                                             |
| 4. Strainer                | 12. Temperature and pressure relief valve | 24. Lockshield valve                                                                               |
| 5. Pressure limiting valve | 13. De-stratification pump                |                                                                                                    |
| 6. Non-return valve        | 14. Pressure relief valve                 |                                                                                                    |
| 7. Expansion vessel        | 15. Pressure relief valve                 |                                                                                                    |
| 8. Expansion relief valve  | 16. Gas shut-off valve                    |                                                                                                    |
|                            | 17. Cold water storage tank               |                                                                                                    |

## Typical NHREC open vented installation schematic

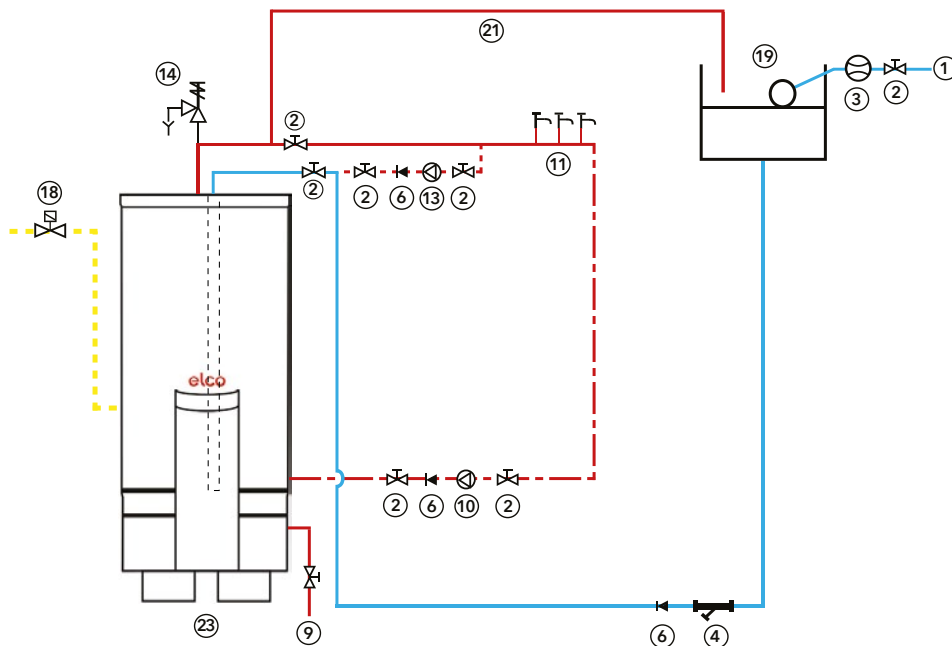

These illustrations are designed to provide general guidance on the hydraulic scheme and should not be considered as an installation drawing.

# Tudor NHREX

**100%**  
**LIKE FOR LIKE**  
**REPLACEMENT**  
(water & gas  
intake & outlet)  
with NHRE



- High efficiency unit ideal for refurbishments
- Extremely low emissions and low noise

- Energy efficiency class: B
- Output from 18 to 52kW

- Up to 320 litres storage capacity
- Continuous DHW delivery up to 1007 litres/hour

# Tudor NHREX – Perfectly suited to refurbishment projects

## Patented lining

All surfaces that touch water are coated with the unique patented high integrity lining.

## Low noise and low emissions

Due to the tried and tested design, the unit boasts both low noise and low NOx emissions.

## Improved cylinder design

Redesigned burner housing with welded seams to eliminate the build up of limestone at the bottom of the cylinder.

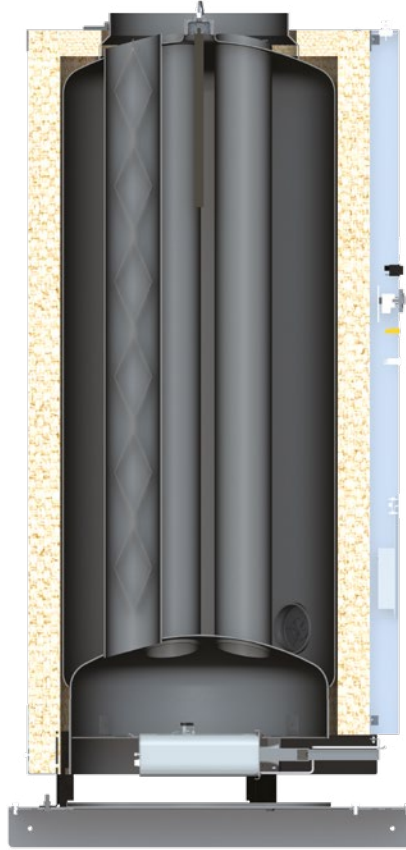

## Dual Cylinder Protection

Protection of the cylinder via the electrical PRO Tech Anode System and the Magnesium Anodes factory fitted as standard.

## Versatility

4 models available as standard in natural gas (G20) and, with an additional transformation kit, they can also work on LPG (G31).

## Easy to maintain

Designed with the contractor in mind, the burner is easily removable for yearly inspection and maintenance.

## Easy to transport

Specialist designed metal base made with the contractor in mind for ease of transport throughout site.

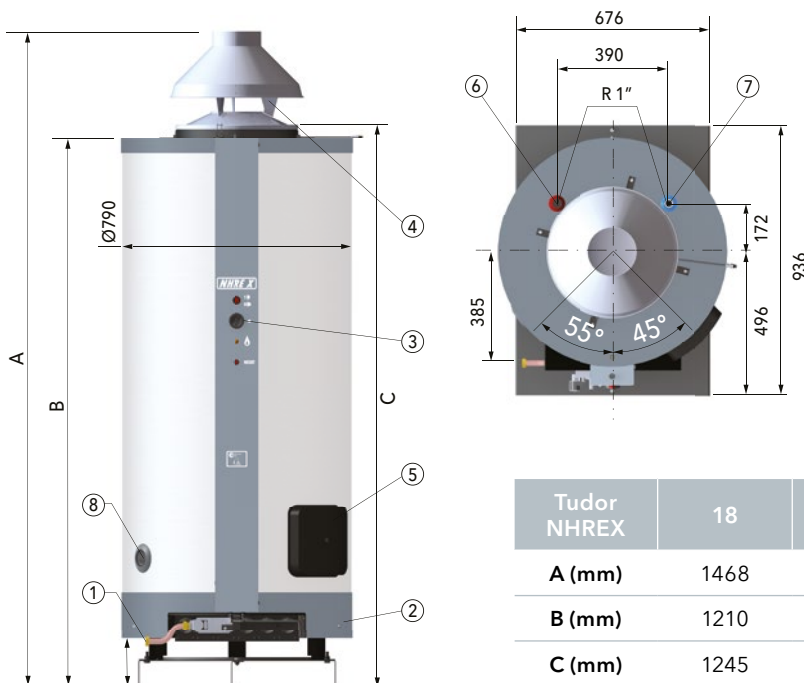

Item No.	Description
1	Gas inlet - nhrex 18 1/2" others 3/4"
2	Atmospheric burner
3	Control panel
4	Draught diverter with spillage stat
5	Inspection cover
6	Hot water outlet 1"
7	Cold water inlet 1"
8	Drain RP 1" 1/2

Tudor NHREX	18	26	36	60
A (mm)	1468	1791	1840	2200
B (mm)	1210	1530	1530	1890
C (mm)	1245	1560	1560	1920

# Technical data – Tudor NHREX

Tudor NHREX		18	26	36	60	
<b>Performance</b>	Storage Capacity	litres	180	250	250	320
	Continuous delivery @ 44°C ΔT	litres/hour	365	543	706	1007
	First hour delivery @ 44°C ΔT	litres	545	793	956	1327
	Continuous delivery @ 50°C ΔT	litres/hour	321	478	621	886
	First hour delivery @ 50°C ΔT	litres	501	728	871	1206
	Continuous delivery @ 56°C ΔT	litres/hour	287	427	554	791
	First hour delivery @ 56°C ΔT	litres	467	677	804	1111
	Operating pressure secondary min/max)	bar	1/7	1/7	1/7	1/7
	Erp load profile		XL	XXL	XXL	XXL
<b>Energy</b>	Gross thermal efficiency	%	85	86.9	86	85.8
	Erp efficiency class		B	B	B	B
	Storage recovery time ΔT 44°C	minutes	30	28	22	19
	Storage recovery time ΔT 50°C	minutes	34	32	25	22
	Storage recovery time ΔT 56°C	minutes	38	36	28	25
	Standby losses	kW/24hr	4	4	4	4
<b>Natural Gas</b>	Gross input - maximum	kW	22	32	42	60
	Net input - maximum	kW	19.8	28.8	37.8	54
	Output to water - maximum	kW	18.7	27.8	36.1	51.5
	Gas inlet pressure - nominal	mbar	20	20	20	20
	Gas flow rate @ 1013mbar & 15°C	m³/h	2.3	3.4	4.5	6.3
<b>LPG</b>	LPG inlet pressure - nominal (min/max)	mbar	31/37	31/37	31/37	31/37
	LPG flow rate @ 1013mbar & 15°C	kg/h	1.3	1.71	1.8	2.3
<b>Flue</b>	Approximate flue gas volume (maximum output)	m³/h	90	129.6	176.4	248.4
	Flue gas temperature (maximum output)	°C	120	130	135	130
	NOx emissions (BS EN 15502)	mg/kWh	33	28	34	19
<b>Electrical</b>	Recommended electrical protection	Amps	3	3	3	3
	Full load run current	Amps	0.02	0.09	0.09	0.09
	Electrical supply	V/Hz	230/50	230/50	230/50	230/50
	Voltage tolerance Volts/Hz	%V/%Hz	+10-6/+1			
<b>Misc</b>	PROtech anode included	yes/no	yes	yes	yes	yes
	Sound power (Lwa) indoors	dB(A)	49	49.2	49.8	50.8
	Weight empty/full	kg	165/350	196/450	196/450	245/570
	Approximate shipping weight	kg	180	211	211	260

**Note:** Tudor NHREX can be either Natural Gas or LPG

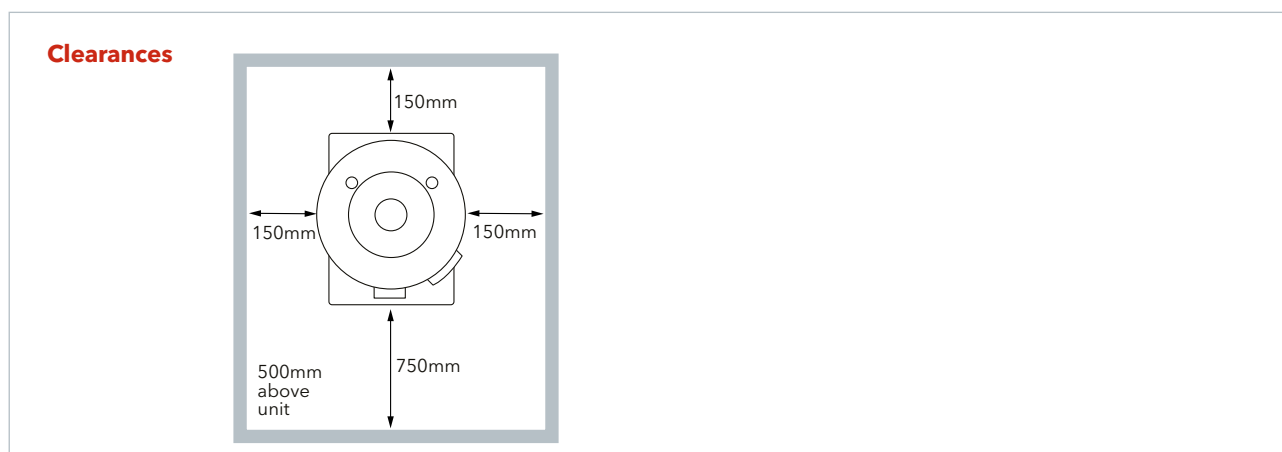

# Examples of hydraulic schemes - Tudor NHREX

## Typical NHREX unvented installation schematic

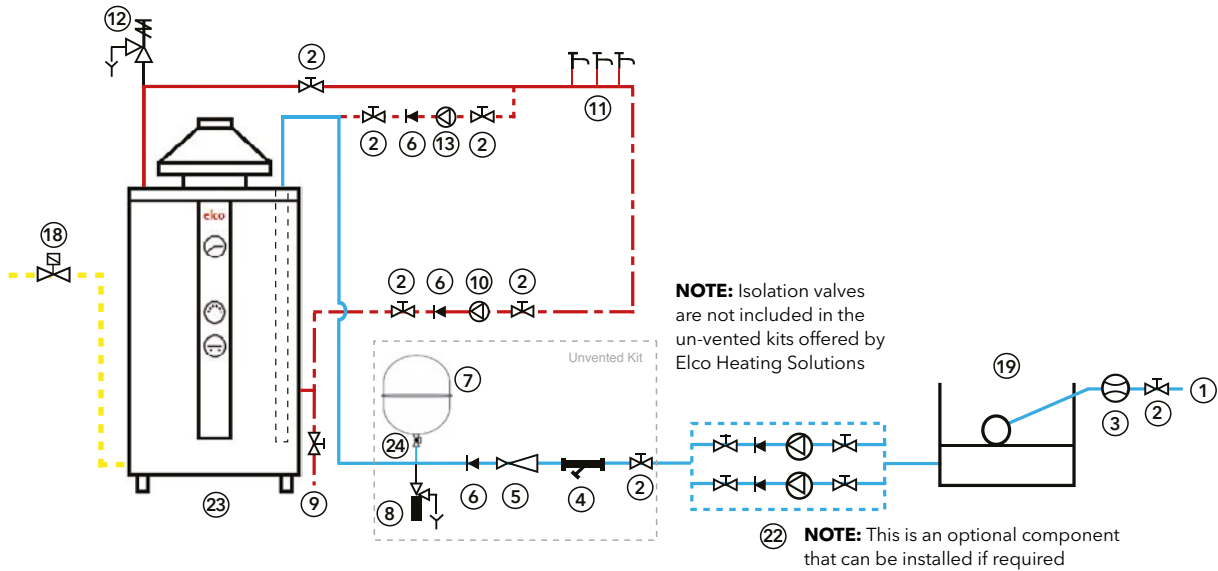

- |                            |                                           |                                                                                                    |
|----------------------------|-------------------------------------------|----------------------------------------------------------------------------------------------------|
| 1. Cold water supply       | 9. Drain                                  | 21. Open vent pipe                                                                                 |
| 2. Isolation valve         | 10. DHW secondary re-circulation pump     | 22. Cold water booster pump set<br>This is an optional component that can be installed if required |
| 3. Water meter             | 11. Hot water outlets                     | 23. NHREX water heater                                                                             |
| 4. Strainer                | 12. Temperature and pressure relief valve | 24. Lockshield valve                                                                               |
| 5. Pressure limiting valve | 13. De-stratification pump                |                                                                                                    |
| 6. Non-return valve        | 14. Pressure relief valve                 |                                                                                                    |
| 7. Expansion vessel        | 18. Gas shut-off valve                    |                                                                                                    |
| 8. Expansion relief valve  | 19. Cold water storage tank               |                                                                                                    |

## Typical NHREX open vented installation schematic

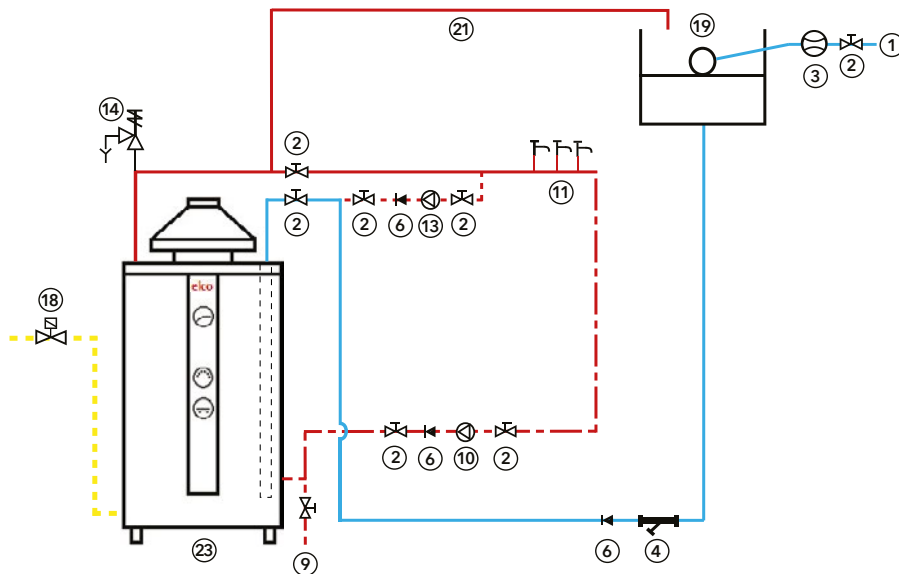

For more schematics please refer to the Installation and Operation manual or contact ELCO Heating Solutions

These illustrations are designed to provide general guidance on the hydraulic scheme and should not be considered as an installation drawing.

# Inox-Maxi SSC1 Calorifiers



- Stainless steel calorifiers
- Extremely low standby heat losses
- Large coil surface area

- Large connections
- Large inspection hatch
- Up to 2000 litres storage capacity

- Continuous delivery at 50°C rise up to 1305 l/h

# Inox-Maxi SSC1 Calorifiers – Stainless steel, perfect for tough conditions

## Durable construction providing peace of mind

Constructed from 316L grade stainless steel providing excellent resistance to attack from corrosion.

## Specially designed coil

Unique coil design to reduce cold spots and to assist with annual maintenance.

## Extremely low standby heat losses

Increasing system efficiency due to the extremely low standby heat loss as low as 2.3 kW/24hr.

## Large coil surface area

The specially designed coil has a larger surface area providing better and faster heat transfer.

## Durability

The Inox-maxi SSC1 calorifiers are manufactured from grade 316L stainless steel and in compliance with ErP Eco-Design requirements for Energy Related Products.

## Large connections

Large connections on the cylinder coil which reduces the pressure drop within the unit.

## External control

The stored DHW temperature can be monitored and controlled externally.



## A wide range of sizes available

Six models providing storage capacities ranging from 500 to 2000 litres and heat transfer of between 41kW to 76kW with primary flow temperature at 80°C.

## Cost effective

Due to the stainless steel construction of the unit, the cost of the yearly maintenance of the unit is greatly reduced by not requiring sacrificial anodes.

## Removable jacket

800L models and above are supplied with removable jackets and insulation.

## Immersion heater option

ELCO offers the option of adding an immersion heater to aid in the recovery time of the cylinder. For more information please see the table on the right.

## Inspection hatch

Easy access to the base of the cylinder through the inspection hatch for yearly maintenance.

## Accessories

Matched optional/additional un-vented kits are available to assist with installation.

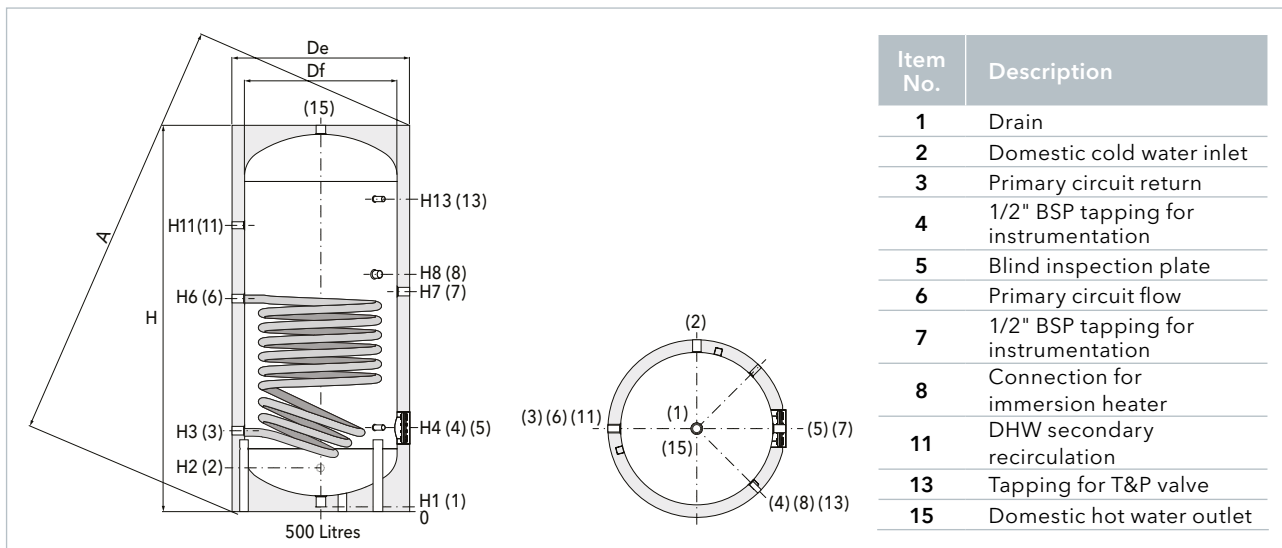

## Dimensions

Inox-Maxi SSC1	Df	De	H	A	H1	H2	H3	H4	H6	H7	H8	H11	H13
	(mm)												
500	650	750	1790	1941	71	256	356	411	1046	1086	1154	1341	1496
800	790	1010	1943	2008	114	322	422	477	997	1086	1112	1330	1532
1000	800	1020	2192	2251	112	337	412	477	1256	1086	1337	1557	1792
1300	950	1170	2213	2289	118	313	438	483	1213	1086	1318	1578	1798
1500	1000	1220	2197	2280	94	327	452	497	1227	1086	1302	1542	1762
2000	1250	1470	2070	2205	85	350	475	520	1035	1086	1160	1390	1575



# Technical data – Inox-Maxi SSC1 Calorifiers

Inox-Maxi SSC1		500	800	1000	1300	1500	2000		
Water	Cylinder capacity	litres	503	759	902	1272	1398	2018	
	<b>Performance data when Primary flow 80°C and return 60°C</b>								
	Output at primary temp 80/60°C	kW	40.7	48.2	62.0	69.0	69.0	75.9	
	Coil nominal primary flow rate at primary temp 80/60°C	litres/sec	0.50	0.59	0.76	0.84	0.84	0.93	
	Pressure loss via coil at the nominal primary flow rate	Kpa	6.0	1.9	3.6	4.8	4.8	6.2	
	Peak 10 minute DHW delivery at ΔT 50°C with primary temp 80/60°C	litres	620	897	1080	1470	1596	2236	
	Continuous DHW delivery ΔT 50°C with primary temp 80/60°C	litres/hour	699	828	1067	1186	1186	1305	
	Cylinder capacity recovery time DHW ΔT 50°C, with primary temp 80°C and nominal flow rate	minutes	54	69	63	81	88	116	
	<b>Performance data when Primary flow 80°C and return 70°C</b>								
	Output at primary temp 80/70°C	kW	44.9	54.2	69.0	76.4	76.4	83.9	
	Coil nominal primary flow rate at primary temp 80/70°C	litres/sec	1.10	1.33	1.69	1.87	1.87	2.05	
	Pressure loss via coil at the nominal primary flow rate	Kpa	24.3	7.9	15.0	19.7	19.7	25.2	
	Peak 10 minute DHW delivery at ΔT 50°C with primary temp 80/70°C	litres	632	914	1100	1491	1617	2258	
	Continuous DHW delivery ΔT 50°C with primary temp 80/70°C	litres/hour	773	932	1187	1314	1314	1442	
	Cylinder capacity recovery time DHW ΔT 50°C, with primary temp 80°C and nominal flow rate	minutes	45	57	53	68	74	98	
	Primary/secondary operating pressure (maximum)	bar	12/6						
	Primary/secondary operating temperature (maximum)	°C	110/95						
	Energy	Standby heat loss (DHW temperature 65°C)	kW/24hr	2.3	2.7	2.8	3.5	3.8	4.3
		Energy class		C	C	C	C	C	C
Electrical	Optional electric elements	kW/phase	3/1	3/1	12/3	12/3	12/3	12/3	
Miscellaneous	Coil connections sizes	inches	1"	1¼"	1¼"	1¼"	1¼"	1¼"	
	Coil surface area	m²	2.1	2.7	3.4	3.7	3.7	4.1	
	Weight empty	kg	100	160	185	250	262	377	
	Weight full	kg	603	919	1087	1522	1660	2395	
	Width of cylinder (DE)	mm	750	1010	1020	1170	1220	1470	
	Height of cylinder (H)	mm	1790	1943	2192	2212	2197	2070	

## Connections

Inox-Maxi SSC1	1	2	3 & 6	5	8	11	13	15
	Gas F							
500	1/2"	1"	1"	Øi 180mm	1 1/2"	1"	1/2"	1"
800	3/4"	1"	1 1/4"	Øi 180mm	2"	1"	3/4"	1 1/4"
1000	3/4"	1"	1 1/4"	Øi 180mm	2"	1"	3/4"	1 1/4"
1300	1"	2"	1 1/4"	Øi 240mm	2"	2"	3/4"	2"
1500	1"	2"	1 1/4"	Øi 240mm	2"	2"	3/4"	2"
2000	1"	2"	1 1/4"	Øi 240mm	2"	2"	3/4"	2"

# Examples of hydraulic schemes - Inox-Maxi SSC1

## Typical DHW schematic with a single coil calorifier SSC1 and TRIGON® XL gas fired boiler and 1 heating circuit with 3 way mixing valve

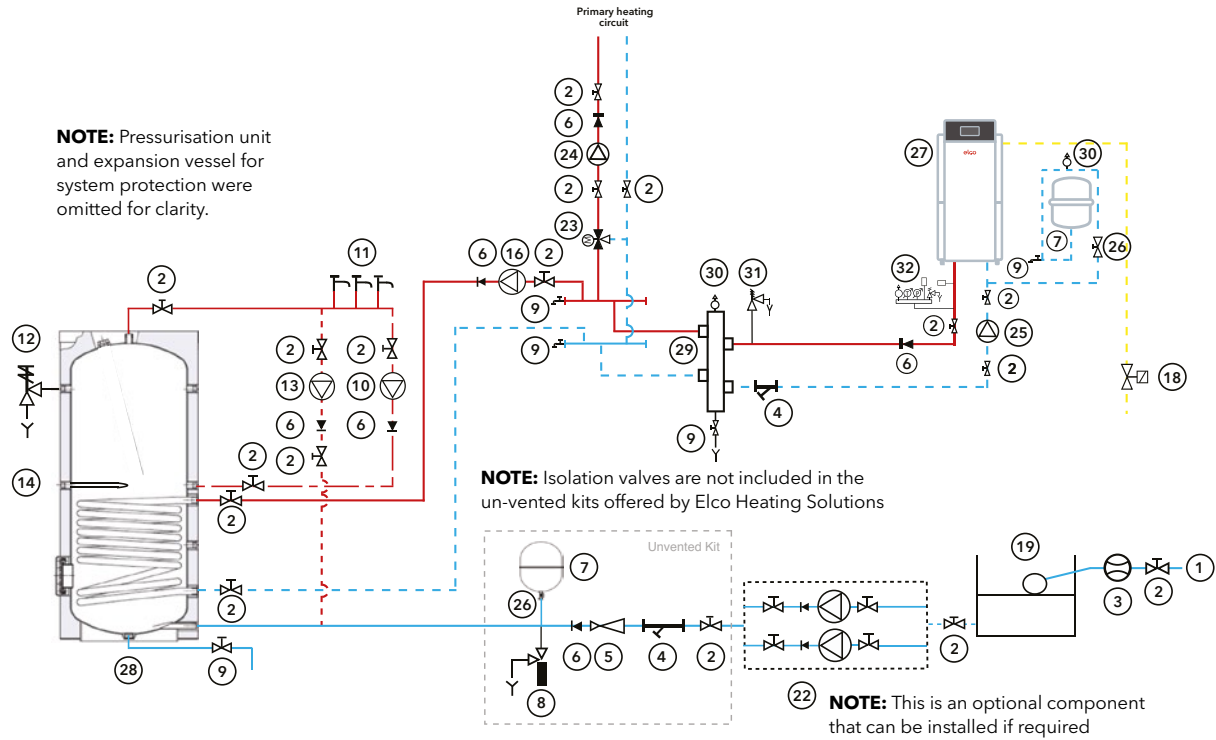

- |                            |                                           |                                     |
|----------------------------|-------------------------------------------|-------------------------------------|
| 1. Cold water supply       | 10. DHW secondary re-circulation pump     | 23. 3 Way motorised valve           |
| 2. Isolation valve         | 11. Hot water outlets                     | 24. Heating circuit pump            |
| 3. Water meter             | 12. Temperature and pressure relief valve | 25. Boiler primary circulating pump |
| 4. Strainer                | 13. De-stratification pump                | 26. Lockshield valve                |
| 5. Pressure limiting valve | 14. Immersion heater                      | 27. TRIGON® XL boiler               |
| 6. Non-return valve        | 16. Primary DHW circulation pump          | 28. SSC1 single coil calorifier     |
| 7. Expansion vessel        | 18. Gas shut-off valve                    | 29. Low loss header                 |
| 8. Expansion relief valve  | 19. Cold water storage tank               | 30. Automatic air vent              |
| 9. Drain                   | 22. Cold water booster pump set           | 31. System safety valve             |
|                            |                                           | 32. Boiler safety group             |

For more schematics please refer to the Installation and Operation manual or contact ELCO Heating Solutions

These illustrations are designed to provide general guidance on the hydraulic scheme and should not be considered as an installation drawing.

### Clearances

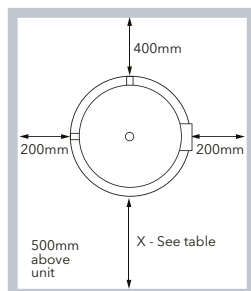

Inox-Maxi SSC1	500	800	1000	1300	1500	2000
<b>X (mm)</b>	750	1010	1020	1210	1260	1510

# Polywarm PWC1 Calorifiers



- Cost effective
- Extremely low standby heat losses
- Large coil surface area

- Large connections
- Large inspection hatch

- Up to 1500 litres storage capacity
- Continuous delivery at 50°C rise up to 1264 l/h

# Technical data - Polywarm PWC1 Calorifiers

## Large connections

Large connections on the cylinder coil which reduces the pressure drop within the unit.

## Extremely low standby heat losses

Increasing system efficiency due to the extremely low standby heat loss as low as 2.5 kW/24hr.

## Unique coil design

Unique coil design to reduce cold spots and to assist with maintenance.

## Large coil surface area

The specially designed coil has a larger surface area providing better and faster heat transfer.

## Immersion heater option

Availability of an optional immersion element

## Economic

One of the most cost effective products on the market.

## Unvented kits

Matched optional/additional unvented kits are available to assist with installation.



## Unique design

The Polywarm PWC1 calorifiers are manufactured from carbon steel with a patented WRAS approved internal liner. The units are in compliance with ErP-Eco Design Requirements for Energy Related Products

## Compliance

Certified to KIWA UK Regulation 4

## A range of sizes

Four models providing storage capacities ranging from 500 to 1500 litres and heat transfer of between 34.4 and 73.5kW with primary flow temperature at 80°C.

## Insulation

All models are supplied with insulation and a removable jacket.

## External control

The stored DHW temperature can be monitored and controlled externally.

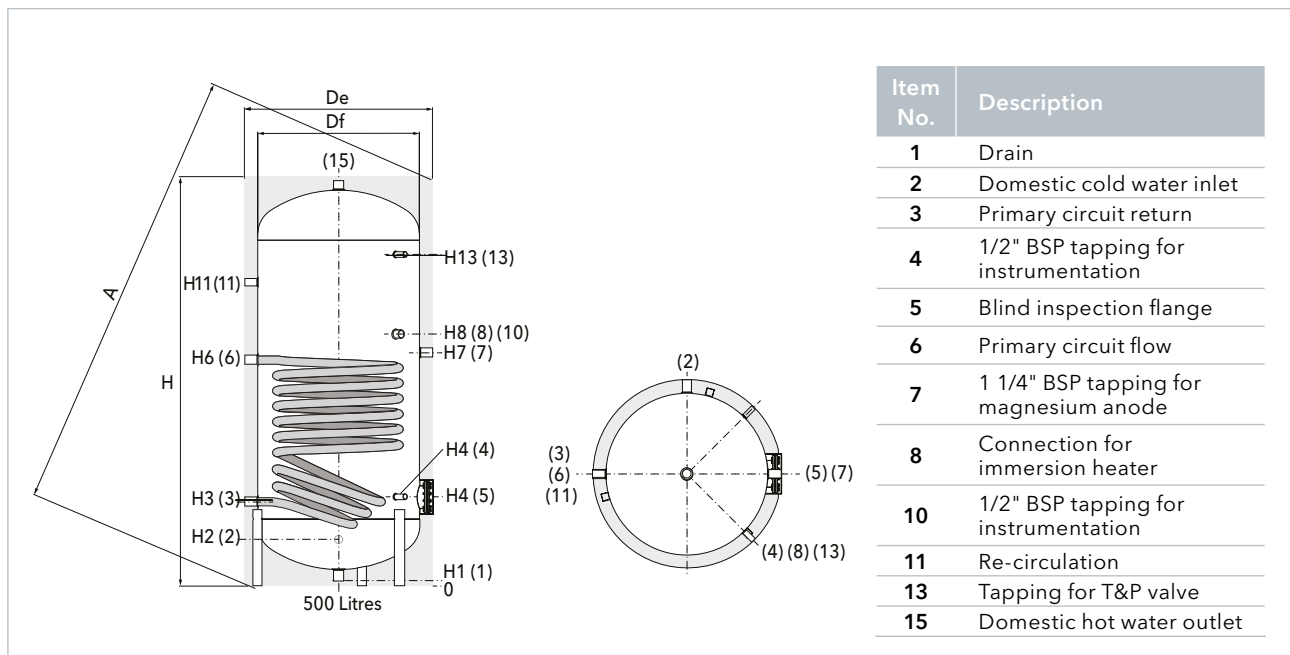

## Dimensions

Polywarm PWC1	Df	De	H	A	H1	H2	H3	H4	H6	H7	H8	H11	H13
	(mm)												
500	650	750	1780	1932	71	271	346	411	1036	1076	1144	1331	1476
800	750	900	2163	2343	101	493	428	483	1181	1243	1308	1598	1858
1000	850	1070	2217	2281	89	524	439	499	1279	1309	1364	1584	1819
1500	950	1170	2415	2485	109	450	425	575	1403	1450	1515	1825	2065

# Technical data - Polywarm PWC1 Calorifiers

Polywarm PWC1		500	800	1000	1500	
Water	Cylinder capacity	litres	489	789	1038	1443
	<b>Performance data when Primary flow 80°C and return 60°C</b>					
	Output at primary temp 80/60°C	kW	34.4	50.6	67.2	73.5
	Coil nominal primary flow rate at primary temp 80/60°C	litres/sec	0.42	0.62	0.82	0.90
	Pressure loss via coil at the nominal primary flow rate	Kpa	3.7	2.1	4.3	5.4
	Peak 10 minute DHW delivery at ΔT 50°C with primary temp 80/60°C	litres	601	904	1095	1609
	Continuous DHW delivery ΔT 50°C with primary temp 80/60°C	litres/hour	591	870	1156	1264
	Cylinder capacity recovery time DHW ΔT 50°C, with primary temp 80°C and nominal flow rate	minutes	62	68	67	86
	<b>Performance data when Primary flow 80°C and return 70°C</b>					
	Output at primary temp 80/70°C	kW	38.3	57.0	74.8	81.5
	Coil nominal primary flow rate at primary temp 80/70°C	litres/sec	0.94	1.40	1.83	2.00
	Pressure loss via coil at the nominal primary flow rate	Kpa	15.2	8.6	17.7	22.3
	Peak 10 minute DHW delivery at ΔT 50°C with primary temp 80/70°C	litres	613	922	1116	1632
	Continuous DHW delivery ΔT 50°C with primary temp 80/70°C	litres/hour	659	980	1286	1402
	Cylinder capacity recovery time DHW ΔT 50°C, with primary temp 80°C and nominal flow rate	minutes	52	56	56	72
	Primary/secondary operating pressure (maximum)	bar	12/6			
Primary/secondary operating temperature (maximum)	°C	110/95				
Energy	Standby heat loss (DHW temperature 65°C)	kW/24hr	2.5	2.8	3.3	3.9
	Energy class		C	C	C	C
Electrical	Optional electric elements	kW/phase	3/1	3/1	12/3	12/3
Miscellaneous	Coil connections sizes		1 1/4"			
	Coil surface area	m <sup>2</sup>	2.5	2.8	3.3	3.9
	Weight empty	kg	108	188	223	318
	Weight full	kg	597	977	1261	1761
	Width of cylinder (DE)	mm	750	900	1070	1170
	Height of cylinder (H)	mm	1780	2163	2217	2415

## Connections

Polywarm PWC1	1	2	3, 6 & 7	4 & 10	5	8	11	13	15
	Gas F								
500	1 1/4"	1"	1 1/4"	1/2"	Øi 180mm	1 1/2"	1"	1/2"	1 1/4"
800	3/4"	1"	1 1/4"	1/2"	Øi 240mm	2"	1"	3/4"	1 1/4"
1000	3/4"	1 1/4"	1 1/4"	1/2"	Øi 240mm	2"	1"	3/4"	1 1/2"
1500	1"	1 1/2"	1 1/4"	1/2"	Øi 380mm	2"	1"	3/4"	2"

# Examples of hydraulic schemes - Polywarm PWC1

## Typical DHW schematic with a single coil calorifier PWC1 and 2 THISION® L ECO gas fired boilers and 1 heating circuit with 3 way mixing valve

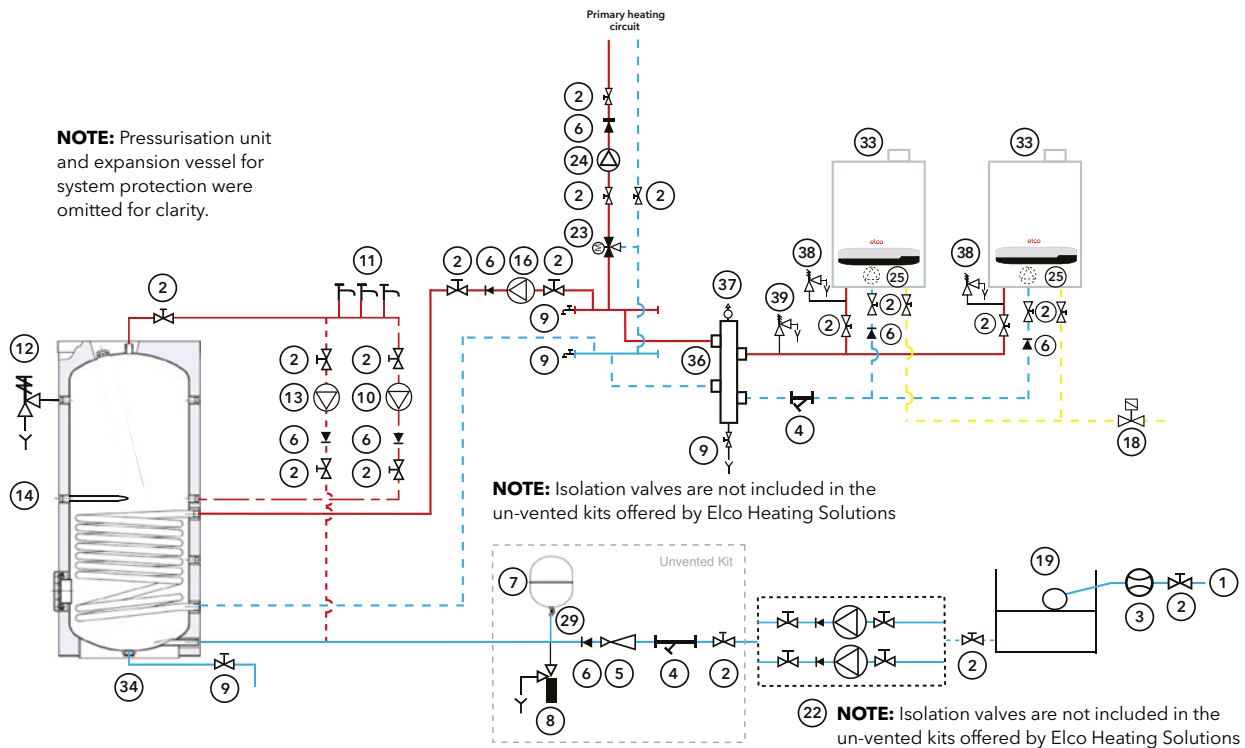

- |                            |                                           |                                 |
|----------------------------|-------------------------------------------|---------------------------------|
| 1. Cold water supply       | 10. DHW secondary re-circulation pump     | 23. 3 Way motorised valve       |
| 2. Isolation valve         | 11. Hot water outlets                     | 24. Heating circuit pump        |
| 3. Water meter             | 12. Temperature and pressure relief valve | 25. Boiler primary pump         |
| 4. Strainer                | 13. De-stratification pump                | 29. Lockshield valve            |
| 5. Pressure limiting valve | 14. Immersion heater                      | 33. THISION® L ECO Boiler       |
| 6. Non-return valve        | 16. DHW primary circulation pump          | 34. PWC1 single coil calorifier |
| 7. Expansion vessel        | 18. Gas shut-off valve                    | 36. Low loss header             |
| 8. Expansion relief valve  | 19. Cold water storage tank               | 37. Automatic air vent          |
| 9. Drain                   | 22. Cold water booster pump set           | 38. Safety valve                |
|                            |                                           | 39. System safety valve         |

For more schematics please refer to the Installation and Operation manual or contact ELCO Heating Solutions

These illustrations are designed to provide general guidance on the hydraulic scheme and should not be considered as an installation drawing.

### Clearances

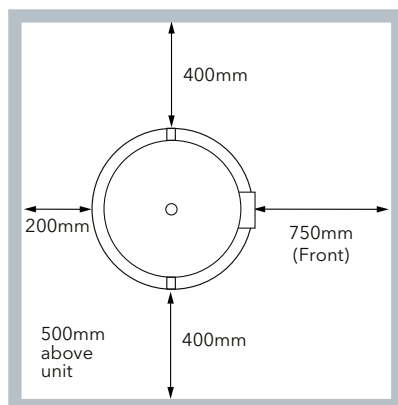

# Inox-Maxi SSC2 Calorifiers



- Stainless steel calorifiers
- Extremely low standby heat losses
- 2 large coil surface areas

- Large connections
- Large inspection hatch
- Up to 2000 litres storage capacity

- Continuous delivery at 50°C rise from both coils up to 2398 l/h

# Inox-Maxi SSC2 Calorifiers – Stainless steel, twin coil

## Durable construction providing peace of mind

Constructed from 316L grade stainless steel providing excellent resistance to attack from corrosion.

## Specially designed coil

Unique coil design to reduce cold spots and to assist with annual maintenance.

## Extremely low standby heat losses

Increasing system efficiency due to the extremely low standby heat loss as low as 2.3 kW/24hr.

## Large coil surface area

The specially designed coil has a larger surface area providing better and faster heat transfer.

## Durability

The Inox-maxi SSC1 calorifiers are manufactured from grade 316L stainless steel and in compliance with ErP Eco-Design requirements for Energy Related Products.

## Large connections

Large connections on the cylinder coil which reduces the pressure drop within the unit.

## External control

The stored DHW temperature can be monitored and controlled externally.



## Future-proof

Suitable to be used with renewable heat sources including solar and heat pumps.

## A wide range of sizes

Six models providing storage capacities ranging from 500 to 2000 litres and heat transfer between 21 to 133kW with primary flow temperature at 80°C.

## Cost effective

Due to the stainless steel construction of the unit, the cost of the yearly maintenance of the unit is greatly reduced by not requiring sacrificial anodes.

## Removable jacket

800L models and above are supplied with removable jackets and insulation.

## Immersion heater option

ELCO offers the option of adding an immersion heater to aid in the recovery time of the cylinder. For more information please see the table on the right.

## Inspection hatch

Easy access to the base of the cylinder through the inspection hatch for yearly maintenance.

## Accessories

Matched optional/additional un-vented kits are available to assist with installation.

## Versatility

Connect coil in series to increase output (not supplied by ELCO)

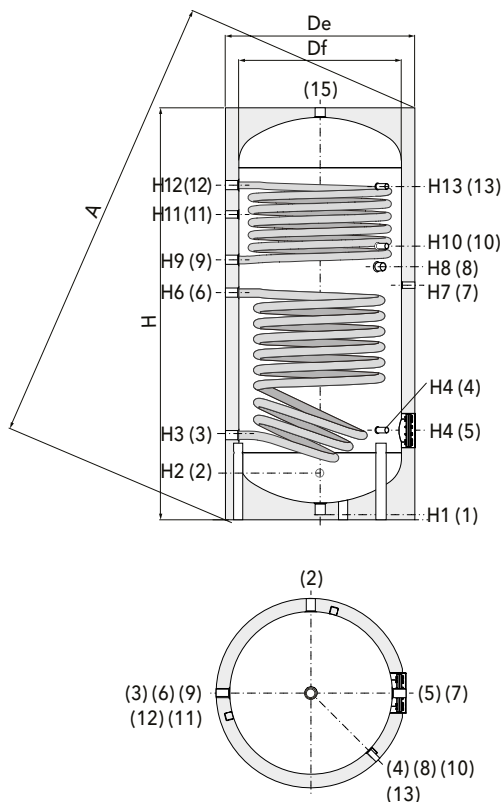

Item No.	Description
1	Drain
2	Domestic cold water inlet
3	Primary circuit return
4	1/2" BSP tapping for instrumentation
5	Blind inspection flange
6	Primary circuit flow
7	1/2" BSP tapping for instrumentation
8	Connection for immersion heater
9	Upper coil return
10	1/2" BSP tapping for instrumentation
11	Re-circulation
12	Upper coil flow
13	T&P valve
15	Domestic hot water outlet



# Technical data – Inox-Maxi SSC2 Calorifiers

INOX-MAXI SSC2		500	800	1000	1300	1500	2000	
Water	Cylinder capacity (Total)	litres	503	759	902	1272	1398	2018
	Upper coil heated volume	litres	162	297	329	465	528	793
	<b>Performance data Upper Coil when Primary flow 80°C and return 60°C</b>							
	Upper Coil Output at primary temp 80/60°C	kW	21	25	28	36	36	40
	Upper Coil nominal primary flow rate at primary temp 80/60°C	litres/sec	0.3	0.3	0.4	0.4	0.4	0.5
	Pressure loss via Upper coil at the nominal primary flow rate	Kpa	1.0	0.3	0.5	0.9	0.9	1.2
	Peak 10 minute DHW delivery at ΔT 50°C with primary temp 80/60°C	litres	222	367	411	569	632	908
	Continuous DHW delivery ΔT 50°C with primary temp 80/60°C	litres/hour	359	423	490	624	624	692
	Cylinder capacity recovery time DHW ΔT 50°C, with primary temp 80°C and nominal flow rate	minutes	34	54	51	56	64	86
	<b>Performance data Lower Coil when Primary flow 80°C and return 60°C</b>							
	Lower Coil Output at primary temp 80/60°C	kW	41	48	62	69	69	76
	Lower Coil nominal primary flow rate at primary temp 80/60°C	litres/sec	0.5	0.6	0.8	0.8	0.8	0.9
	Pressure loss via lower coil at the nominal primary flow rate	Kpa	6.0	1.9	3.6	4.8	4.8	6.2
	Peak 10 minute DHW delivery at ΔT 50°C with primary temp 80/60°C	litres	620	897	1080	1470	1596	2236
	Continuous DHW delivery ΔT 50°C with primary temp 80/60°C	litres/hour	699	828	1067	1186	1186	1305
	Cylinder capacity recovery time DHW ΔT 50°C, with primary temp 80°C and nominal flow rate	minutes	54	69	63	81	88	116
	<b>Performance data Both Coils connected in series when Primary flow 80°C and return 60°C</b>							
	Both Coils Output at primary temp 80/60°C	kW	65	78	96	111	111	122
	Both Coils nominal primary flow rate at primary temp 80/60°C	litres/sec	0.8	1.0	1.2	1.4	1.4	1.5
	Pressure loss via both coils at the nominal primary flow rate**	Kpa	20.5	6.7	11.5	17.0	17.0	21.9
	Peak 10 minute DHW delivery at ΔT 50°C with primary temp 80/60°C	litres	688	982	1177	1589	1715	2367
	Continuous DHW delivery ΔT 50°C with primary temp 80/60°C	litres/hour	1110	1340	1647	1905	1905	2094
	Cylinder capacity recovery time DHW ΔT 50°C, with primary temp 80°C and nominal flow rate	minutes	34	42	41	50	55	72
	<b>Performance data Both Coils connected in series when Primary flow 80°C and return 70°C</b>							
	Both Coils Output at primary temp 80/70°C	kW	70	86	105	121	121	133
	Both Coils nominal primary flow rate at primary temp 80/70°C	Kpa	1.7	2.1	N/R***	N/R***	N/R***	N/R***
	Pressure loss via both coils at the nominal primary flow rate**	litres	81.2	27.0	46.2	67.4	67.4	86.4
Peak 10 minute DHW delivery at ΔT 50°C with primary temp 80/70°C	litres/hour	705	1005	1203	1619	1745	2398	
Continuous DHW delivery ΔT 50°C with primary temp 80/70°C	minutes	1211	1479	1807	2081	2081	2282	
Cylinder capacity recovery time DHW ΔT 50°C, with primary temp 80°C and nominal flow rate	kW	29	36	35	42	47	61	
Primary/secondary operating pressure (maximum)	bar	12/6						
Primary/secondary operating temperature (maximum)	°C	110/95						
Energy	Standby heat losses (DHW temperature 65°C)	kW/24hr	2.3	2.7	2.8	3.5	3.8	4.3
	Energy class		C	C	C	C	C	C
Electrical	Optional electric elements	kW/phase	3/1	3/1	12/3	12/3	12/3	12/3
Miscellaneous	Upper Coil connections sizes	inches	1"	1 1/4"				
	Upper coil surface area	m <sup>2</sup>	1.2	1.5	1.7	2.1	2.1	2.3
	Lower Coil connections sizes	inches	1"	1 1/4"				
	Lower coil surface area	m <sup>2</sup>	2.1	2.7	3.4	3.7	3.7	4.1
	Weight empty/full	kg	138/ 641	191/ 949	220/ 1122	270/ 1542	285/ 1683	415/ 2433
	Width of cylinder (DE)	mm	750	1010	1020	1170	1220	1470
Height of cylinder (H)	mm	1796	1943	2192	2213	2197	2070	

\*\*Both coils connected in series by contractor \*\*\*not recommended due to high primary water velocity

# Technical data – Inox-Maxi SSC2 Calorifiers

## Dimensions

Inox-Maxi SSC2	Df	De	H	A	H1	H2	H3	H4	H6	H7	H8	H9	H10	H11	H12	H13
	(mm)															
500	650	750	1796	1946	71	271	356	411	1046	1086	1154	1196	1274	1341	1485	1496
800	790	1010	1943	2008	114	323	423	478	998	1533	1113	1163	1260	1331	1475	1533
1000	800	1020	2192	2251	112	337	412	477	1256	1792	1337	1372	1432	1557	1792	1792
1300	950	1170	2213	2289	118	313	438	483	1213	1798	1368	1368	1427	1578	1788	1798
1500	1000	1220	2197	2280	94	327	452	497	1227	1762	1302	1332	1462	1542	1752	1762
2000	1250	1470	2070	2197	85	350	475	520	1035	1575	1160	1215	1345	1390	1565	1575

## Connections

Inox-Maxi SSC2	1	2	3 & 6	5	8	9 & 12	11	13	15
	Gas F								
500	1/2"	1"	1"	Øi 120mm	1 1/4"	1"	1"	3/4"	1"
800	3/4"	1"	1 1/4"	Øi 120mm	2"	1 1/4"	1"	1 1/4"	1 1/4"
1000	3/4"	1"	1 1/4"	Øi 120mm	2"	1 1/4"	1"	1 1/4"	1 1/4"
1300	1"	1 1/4"	1 1/4"	Øi 160mm	2"	1 1/4"	2"	1 1/4"	2"
1500	1"	2"	1 1/4"	Øi 160mm	2"	1 1/4"	2"	1 1/4"	2"
2000	1"	2"	1 1/4"	Øi 160mm	2"	1 1/4"	2"	1 1/4"	2"

## Clearances

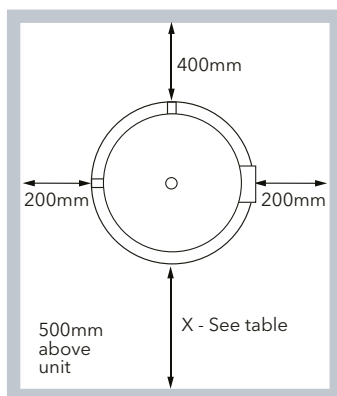

Inox-Maxi SSC2	500	800	1000	1300	1500	2000
X (mm)	750	1010	1020	1210	1260	1510

# Example of Hydraulic Scheme - Twin Coil Calorifiers an Inox-Maxi SSC2 or Polywarm PWC2

## Typical DHW schematic with a twin coil calorifier SSC2 or PWC2, 2 heating sources - THISION® L ECO gas fired boiler and solar panels and 1 heating circuit with 3 way mixing valve

When connecting any renewable energy source to a calorifier, it is important to confirm that the surface area of the primary coil is suitable.

**NOTE:** Pressurisation unit and expansion vessel for system protection were omitted for clarity.

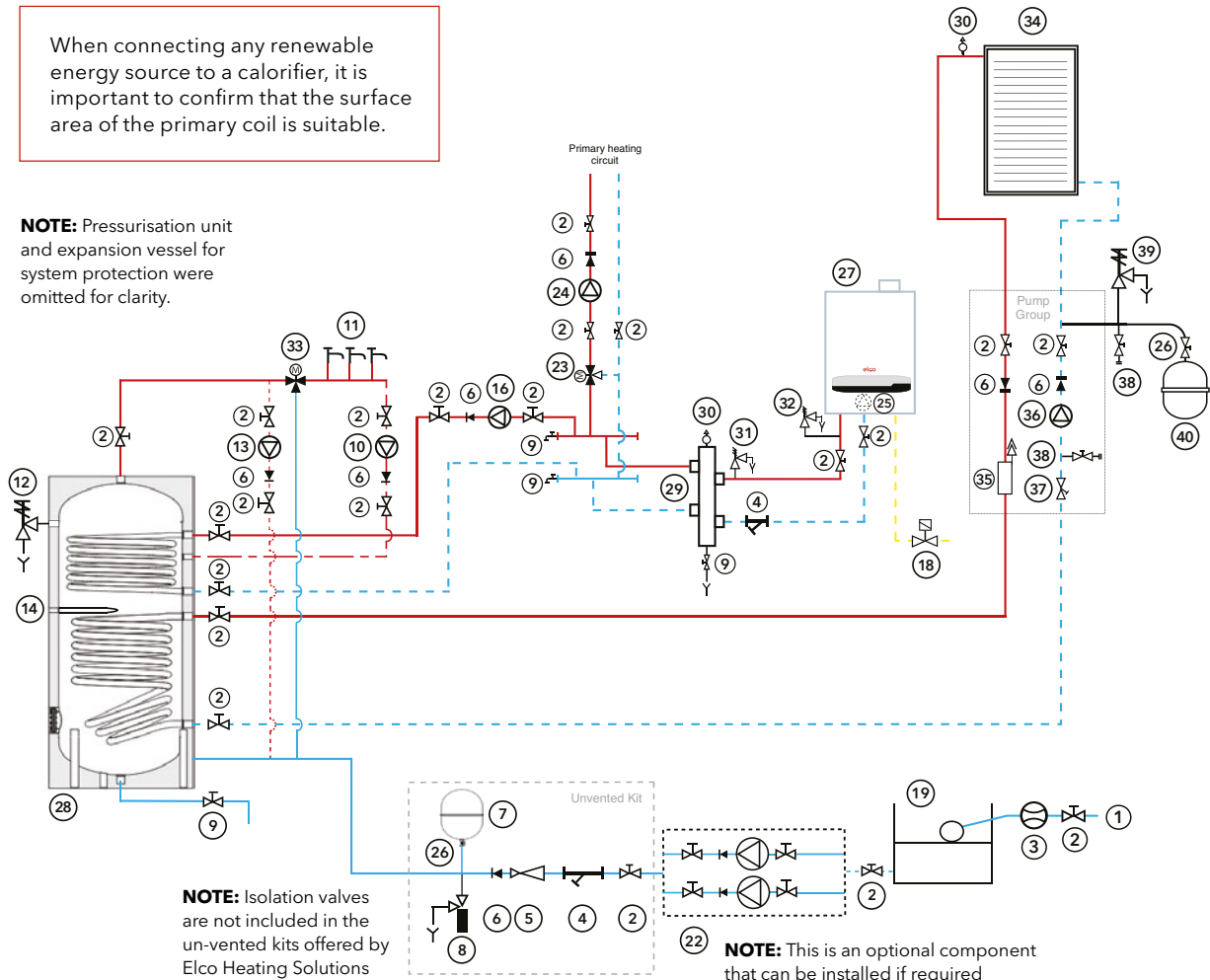

- |                                           |                                       |                                        |
|-------------------------------------------|---------------------------------------|----------------------------------------|
| 1. Cold water supply                      | 13. De-stratification pump            | 29. Low loss header                    |
| 2. Isolation valve                        | 14. Immersion heater                  | 30. Automatic air vent                 |
| 3. Water meter                            | 16. Loading pump                      | 31. System safety valve                |
| 4. Strainer                               | 18. Gas shut-off valve                | 32. Boiler safety valve                |
| 5. Pressure limiting valve                | 19. Cold water storage tank           | 34. Solar panel                        |
| 6. Non-return valve                       | 22. Cold water booster pump set       | 35. Vent pipe                          |
| 7. Expansion vessel                       | 23. 3 Way motorised valve             | 36. Solar pump                         |
| 8. Expansion relief valve                 | 24. Heating circuit pump              | 37. Flowcon valve                      |
| 9. Drain                                  | 25. Boiler circulating pump           | 38. Flush and fill valve with end caps |
| 10. DHW secondary re-circulation pump     | 26. Lockshield valve                  | 39. Solar safety valve                 |
| 11. Hot water outlets                     | 27. THISION® L ECO boiler             | 40. Solar expansion vessel             |
| 12. Temperature and pressure relief valve | 28. SSC2 or PWC2 twin coil calorifier |                                        |

For more schematics please refer to the Installation and Operation manual or contact ELCO Heating Solutions

These illustrations are designed to provide general guidance on the hydraulic scheme and should not be considered as an installation drawing.

# Polywarm PWC2 Calorifiers



- Cost effective
- Extremely low standby heat losses
- 2 Large coil surface area

- Large connections
- Large inspection hatch
- Up to 1500 litres storage capacity

- Continuous delivery at 50°C rise from both coils up to 2113 l/h

# Polywarm PWC2 Calorifiers – Twin coil, economical

## Large connections

Large connections on the cylinder coil which reduces the pressure drop within the unit.

## Extremely low standby heat losses

Increasing system efficiency due to the extremely low standby heat loss as low as 2.5 kWh/24hr.

## Unique coil design

Unique coil design to reduce cold spots and to assist with maintenance.

## Large coil surface area

The two specially designed coils have a large surface area providing better and faster heat transfer.

## Immersion heater option

Availability of an optional immersion element

## Economic

One of the most cost effective products on the market.

## Unvented kits

Matched optional/additional unvented kits are available to assist with installation.



## Unique design

The Polywarm PWC2 calorifiers are manufactured from carbon steel with a patented WRAS approved internal liner. The units are in compliance with ErP-Eco Design Requirements for Energy Related Products

## Compliance

Certified to KIWA UK Regulation 4

## A range of sizes

Four models providing storage capacities ranging from 500 to 1500 litres and heat transfer of between 18 and 122kW with primary flow temperature at 80°C.

## Insulation

All models are supplied with insulation and a removable jacket.

## External control

The stored DHW temperature can be monitored and controlled externally.

## Future-proof

Suitable to be used with renewable heat sources including solar and heat pumps.

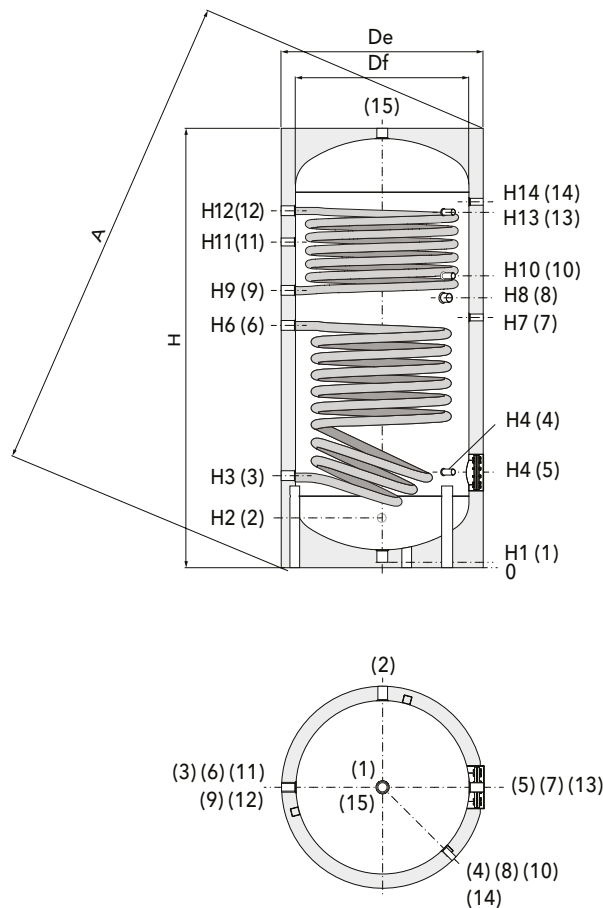

Item No.	Description
1	Drain
2	Domestic cold water inlet
3	Primary circuit return
4	1/2" BSP tapping for instrumentation
5	Blind inspection flange
6	Primary circuit flow
7	1/2" BSP tapping for instrumentation
8	Connection for immersion heater
9	Upper coil return
10	1/2" BSP tapping for instrumentation
11	Re-circulation
12	Upper coil flow
13	T&P valve
14	1/2" BSP tapping for instrumentation
15	Domestic hot water outlet

# Technical data – Polywarm PWC2 Calorifiers

Polywarm PWC2		500	800	1000	1500	
Water	Cylinder capacity (Total)	litres	503	759	902	1398
	Upper coil heated volume	litres	162	290	374	502
	<b>Performance data Upper Coil when Primary flow 80°C and return 60°C</b>					
	Upper Coil Output at primary temp 80/60°C	kW	18	26	34	33
	Upper Coil nominal primary flow rate at primary temp 80/60°C	litres/sec	0.22	0.32	0.42	0.40
	Pressure loss via Upper coil at the nominal primary flow rate	Kpa	0.67	0.36	0.73	0.67
	Peak 10 minute DHW delivery at ΔT 50°C with primary temp 80/60°C	litres	213	364	472	597
	Continuous DHW delivery ΔT 50°C with primary temp 80/60°C	litres/hour	306	444	585	567
	Cylinder capacity recovery time DHW ΔT 50°C, with primary temp 80°C and nominal flow rate	minutes	40	49	48	67
	<b>Performance data Lower Coil when Primary flow 80°C and return 60°C</b>					
	Lower Coil Output at primary temp 80/60°C	kW	34	51	67	73
	Lower Coil nominal primary flow rate at primary temp 80/60°C	litres/sec	0.4	0.6	0.8	0.9
	Pressure loss via lower coil at the nominal primary flow rate	Kpa	3.7	2.1	4.3	5.4
	Peak 10 minute DHW delivery at ΔT 50°C with primary temp 80/60°C	litres	601	904	1095	1609
	Continuous DHW delivery ΔT 50°C with primary temp 80/60°C	litres/hour	591	870	1156	1264
	Cylinder capacity recovery time DHW ΔT 50°C, with primary temp 80°C and nominal flow rate	minutes	62	68	67	86
	<b>Performance data Both Coils connected in series when Primary flow 80°C and return 60°C</b>					
	Both Coils Output at primary temp 80/60°C	kW	55	82	107	112
	Both Coils nominal primary flow rate at primary temp 80/60°C	litres/sec	0.7	1.0	1.3	1.4
	Pressure loss via both coils at the nominal primary flow rate**	Kpa	12.9	7.3	14.7	16.8
	Peak 10 minute DHW delivery at ΔT 50°C with primary temp 80/60°C	litres	661	994	1209	1720
	Continuous DHW delivery ΔT 50°C with primary temp 80/60°C	litres/hour	950	1407	1839	1930
	Cylinder capacity recovery time DHW ΔT 50°C, with primary temp 80°C and nominal flow rate	minutes	38	42	42	56
	<b>Performance data Both Coils connected in series when Primary flow 80°C and return 70°C</b>					
	Both Coils Output at primary temp 80/70°C	kW	61	90	117	123
	Both Coils nominal primary flow rate at primary temp 80/70°C	litres/sec	1.5	2.2	2.9	3.0
	Pressure loss via both coils at the nominal primary flow rate**	Kpa	51.8	29.5	59.2	67.7
	Peak 10 minute DHW delivery at ΔT 50°C with primary temp 80/70°C	litres	677	1018	1238	1750
	Continuous DHW delivery ΔT 50°C with primary temp 80/70°C	litres/hour	1043	1555	2017	2113
	Cylinder capacity recovery time DHW ΔT 50°C, with primary temp 80°C and nominal flow rate	minutes	33	35	36	47
Primary/secondary operating pressure (maximum)	bar	12/6				
Primary/secondary operating temperature (maximum)	°C	110/95				
Energy	Standby heat losses (DHW temperature 65°C)	kW/24hr	2.4	2.5	3.0	3.8
	Energy class		C	C	C	C
Electrical	Optional electric elements	kW/phase	3/1	3/1	12/3	12/3
Miscellaneous	Upper Coil connections sizes	inches	1 1/4"			
	Upper Coil surface area	m <sup>2</sup>	1	1.5	1.9	1.9
	Lower Coil connections sizes	inches	1 1/4"			
	Lower Coil surface area	m <sup>2</sup>	1.8	2.7	3.5	3.8
	Weight empty/full	kg	130/ 619	216/ 1005	255/ 1293	344/ 1787
	Width of cylinder (DE)	mm	750	1010	1020	1220
	Height of cylinder (H)	mm	1786	2163	2217	2415

\*\* Both coils connected in series by contractor

# Technical data - Polywarm PWC2 Calorifiers

## Dimensions

Polywarm PWC2	Df	De	H	A	H1	H2	H3	H4	H6	H7	H8	H9	H10	H11	H12	H13
	(mm)															
500	650	750	1786	1937	71	271	346	411	1036	1076	1144	1186	1296	1331	1476	1476
800	790	1010	2163	2221	101	493	428	483	1181	1243	1308	1362	1573	1598	1770	1788
1000	800	1020	2217	2275	89	524	439	499	1279	1309	1364	1399	1609	1584	1819	1819
1500	1000	1220	2415	2491	109	450	425	575	1352	1450	1515	1550	1735	1825	2045	2065

## Connections

Polywarm PWC2	1	2	3, 6, 9, 12	4, 7, 10	5	8	11	13	14	15
	Gas F									
500	1 1/4"	1"	1 1/4"	1/2"	Øi 180mm	1 1/2"	1"	3/4"	1 1/4"	1 1/4"
800	3/4"	1"	1 1/4"	1/2"	Øi 240mm	2"	1"	3/4"	1 1/4"	1 1/4"
1000	3/4"	1 1/4"	1 1/4"	1/2"	Øi 240mm	2"	1"	3/4"	1 1/4"	1 1/2"
1500	1"	2"	1 1/4"	1/2"	Øi 380mm	2"	1 1/2"	3/4"	1 1/4"	2"

## Clearances

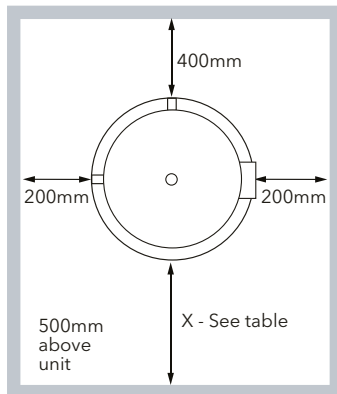

Polywarm PWC2	500	800	1000	1500
<b>X (mm)</b>	750	950	1050	1150

# Example of Hydraulic Scheme – Twin Coil Calorifiers : Inox-Maxi SSC2 or Polywarm PWC2

**Typical DHW schematic with a twin coil calorifier SSC2 or PWC2, 2 heating sources - THISION L ECO gas fired boiler and a Aerotop heat pump and 1 heating circuit with 3 way mixing valve**

When connecting any renewable energy source to a calorifier, it is important to confirm that the surface area of the primary coil is suitable.

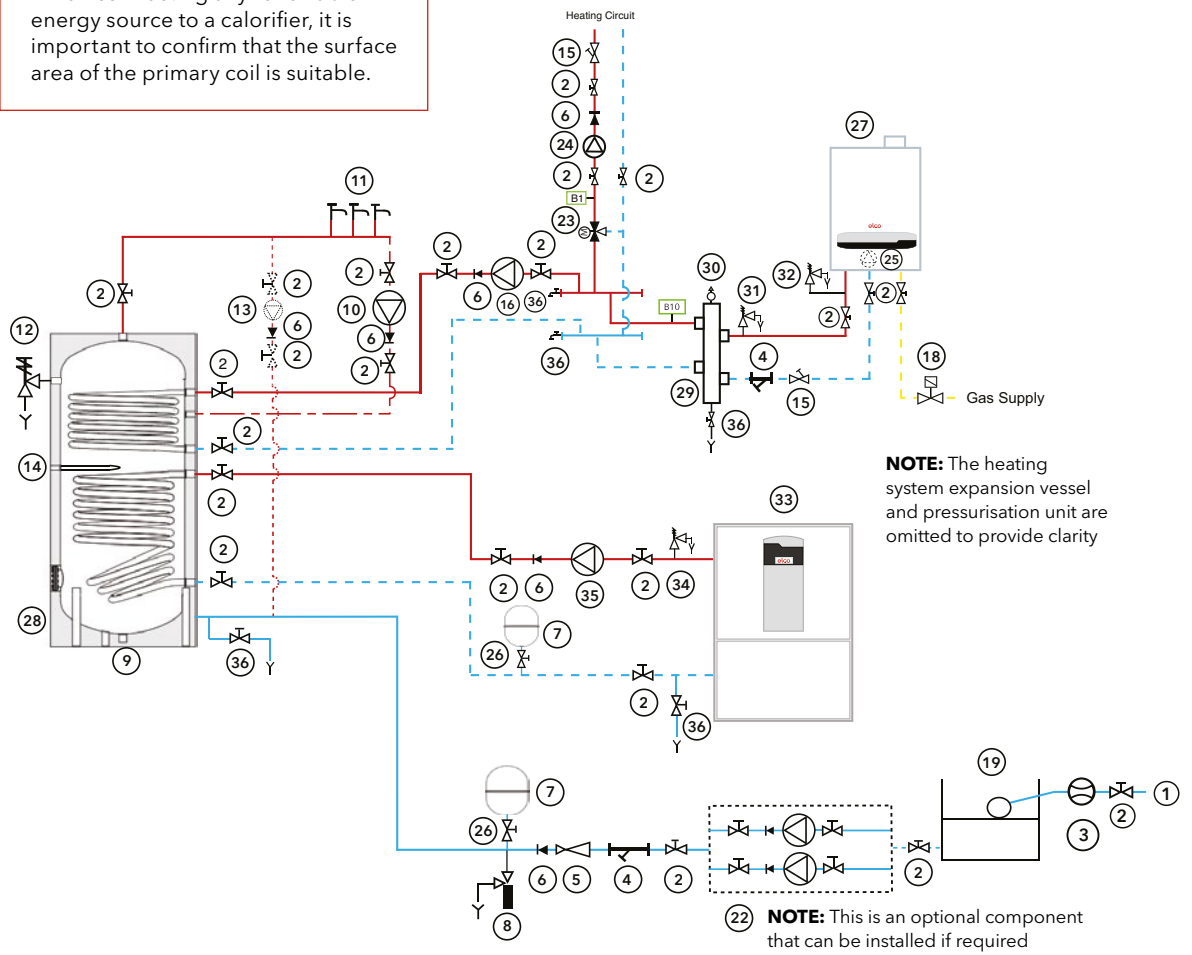

**NOTE:** The heating system expansion vessel and pressurisation unit are omitted to provide clarity

**NOTE:** This is an optional component that can be installed if required

- |                                           |                                       |                                                              |
|-------------------------------------------|---------------------------------------|--------------------------------------------------------------|
| 1. Cold water supply                      | 16. Primary DHW circulation pump      | 31. System safety valve                                      |
| 2. Isolation valve                        | 18. Gas shut-off valve                | 32. Boiler safety valve                                      |
| 3. Water meter                            | 19. Cold water storage tank           | 33. AEROTOP T heat pump                                      |
| 4. Strainer                               | 22. Cold water booster pump set       | 34. Heat pump safety valve                                   |
| 5. Pressure limiting valve                | 23. 3 way motorised valve             | 35. Primary DHW circulation pump from the second heat source |
| 6. Non-return valve                       | 24. Heating circuit pump              | 36. Drain Valve                                              |
| 7. Expansion vessel                       | 25. Boiler circulating pump           |                                                              |
| 8. Expansion relief valve                 | 26. Lockshield valve                  |                                                              |
| 9. Drain                                  | 27. THISION® L ECO boiler             |                                                              |
| 10. DHW secondary re-circulation pump     | 28. SSC2 or PWC2 twin coil calorifier |                                                              |
| 11. Hot water outlets                     | 29. Low loss header                   |                                                              |
| 12. Temperature and pressure relief valve | 30. Automatic air vent                |                                                              |
| 13. De-stratification pump                |                                       |                                                              |
| 14. Immersion heater                      |                                       |                                                              |

For more schematics please refer to the Installation and Operation manual or contact ELCO Heating Solutions

These illustrations are designed to provide general guidance on the hydraulic scheme and should not be considered as an installation drawing.



# Gemini HSCi Tank in Tank Calorifier



- High performance and rapid response calorifier
- No de-stratification pump required

- Comprehensive built in control
- Up to 500 litres DHW storage capacity

- Continuous delivery at 50°C rise up to 1474 l/h
- Can be installed horizontally\*

\*in open vented applications only

# Gemini HSCi Tank in Tank Calorifier – High Performance and Rapid Response

## High performance and rapid response

The Gemini range of high performance Domestic Hot Water Calorifiers utilises the tank-in tank principle of construction, where a corrugated stainless steel secondary vessel is placed within an indirectly heated primary tank. This principle provides a very large heat exchange surface area for high performance and rapid response.

## A range of sizes

This range includes three models from 200 litre through to 500 litre capacity, with first hour performance up to 1974 litres at  $\Delta T$  50°C.

## Low pressure drop

Very low pressure drop on the primary circuit due to the large volume and low velocity of the water.

## No de-stratification pump required

Even temperature across the unit, minimises temperature gradients and eliminates the need for a de-stratification pump.

## Clever construction

The product is finished using injection moulded rigid PVC top and base covers, plus a removable padded vinyl jacket.



## Compliance

The Gemini Calorifier range has been approved to the requirements of the Water Regulations 1999 by the Water Research Advisory Scheme (WRAS).

## Built-in components

Each calorifier is equipped with an injection moulded control panel which houses a dial type thermometer, combination control and manual reset high limit thermostats, immersion heater switch with indicator lamp and electric connection terminal rail.

## Optional immersion heater

The optional 2.5kW immersion heater (7.5kW for 500i) is located in the primary water space below the secondary inner tank, ensuring complete heating, and avoids being secondary water scale fouled.

## Optional kits

Matched optional/additional un-vented kits are available to assist with installation

## Comprehensive built in control

The Gemini comes supplied with the facility to control the following:

- Control and high limit thermostat
- Primary pump
- 3 port primary diverter valve
- 2 port primary control valve
- Power supply to immersion heater

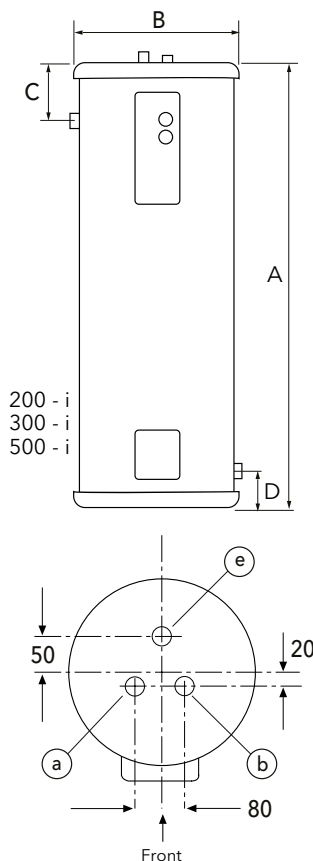

## Dimensions

Model	A	B	C	D
200 - i	1239	620	212	182
300 - i	1724	620	212	182
500 - i	1730	770	237	192

## Connections

Model	Primary Flow & Return c & d	DHW Feed a	DHW Drawoff b	Secondary Return e
200 - i	1" BSP - F	3/4" BSP - M*	3/4" BSP - M*	3/4" BSP - M
300 - i	1" BSP - F	1" BSP - M*	1" BSP - M*	1" BSP - M
500 - i	1 1/2" BSP - F	1" BSP - M*	1" BSP - M*	1" BSP - M

\* Supplied with optional 1 1/2" reducing socket to increase connection size for DHW open vented installations

# Technical data – Gemini HSCi Tank in Tank Calorifier

Gemini HSCi		200i	300i	500i	
Water	Nominal DHW Capacity	litres	193	286	462
	<b>Performance data when Primary flow 80°C and return 60°C</b>				
	Output at primary temp 80/60°C	kW	23	35	45
	Coil nominal primary flow rate at primary temp 80/60°C	litres/sec	0.28	0.42	0.54
	Pressure loss via coil at the nominal primary flow rate	kPa	0.4	1.3	0.8
	Peak 10 minute DHW delivery at ΔT 50°C with primary temp 80/60°C	litres	266	400	629
	Continuous DHW delivery ΔT 50°C with primary temp 80/60°C	litres/hour	397	605	777
	Cylinder capacity recovery time DHW ΔT 50°C, with primary temp 80°C and nominal flow rate	minutes	39	37	46
	<b>Performance data when Primary flow 80°C and return 70°C</b>				
	Output at primary temp 80/70°C	kW	44	67	86
	Coil nominal primary flow rate at primary temp 80/70°C	litres/sec	1.05	1.60	2.05
	Pressure loss via coil at the nominal primary flow rate	kPa	1.7	5.4	3.3
	Peak 10 minute DHW delivery at ΔT 50°C with primary temp 80/70°C	litres	325	491	745
	Continuous DHW delivery ΔT 50°C with primary temp 80/70°C	litres/hour	754	1148	1474
	Cylinder capacity recovery time DHW ΔT 50°C, with primary temp 80°C and nominal flow rate	minutes	21	20	25
	<b>Performance data when Primary flow 85°C and return 65°C</b>				
	Output at primary temp 85/65°C	kW	29	44	57
	Coil nominal primary flow rate at primary temp 85/65°C	litres/sec	0.35	0.53	0.68
	Pressure loss via coil at the nominal primary flow rate	kPa	0.4	1.3	0.8
	Peak 10 minute DHW delivery at ΔT 50°C with primary temp 85/65°C	litres	282	426	661
Continuous DHW delivery ΔT 50°C with primary temp 85/65°C	litres/hour	496	756	971	
Cylinder capacity recovery time DHW ΔT 50°C, with primary temp 85°C and nominal flow rate	minutes	31	30	37	
Energy	Standby heat losses (DHW temperature 65°C)	kW/24hr	1.5	2.4	2.5
	Energy class		B	C	C
Electrical	Optional electric elements	kW/phase	2.5/1	2.5/1	2.5/1 or 7.5/3
Miscellaneous	Maximum Operating Temperature Primary	°C	90		
	Maximum Operating Pressure Primary	bar	3		
	Maximum Operating Pressure Secondary	bar	8		
	Primary Capacity	L	56	65	108
	Heating Surface	m <sup>2</sup>	1.6	2.4	3.1
	Weight Empty/Filled	Kg	78/334	109/481	151/721

**Important Note:** Any Gemini HSC calorifier that is installed in the horizontal plane MUST only be connected to an open vented system. It is not permitted to install a horizontally mounted unit to an unvented hot water system.

# Example of Hydraulic Schemes – Gemini HSCi Tank in Tank Calorifier

## Typical single calorifier with unvented kit and secondary DHW return

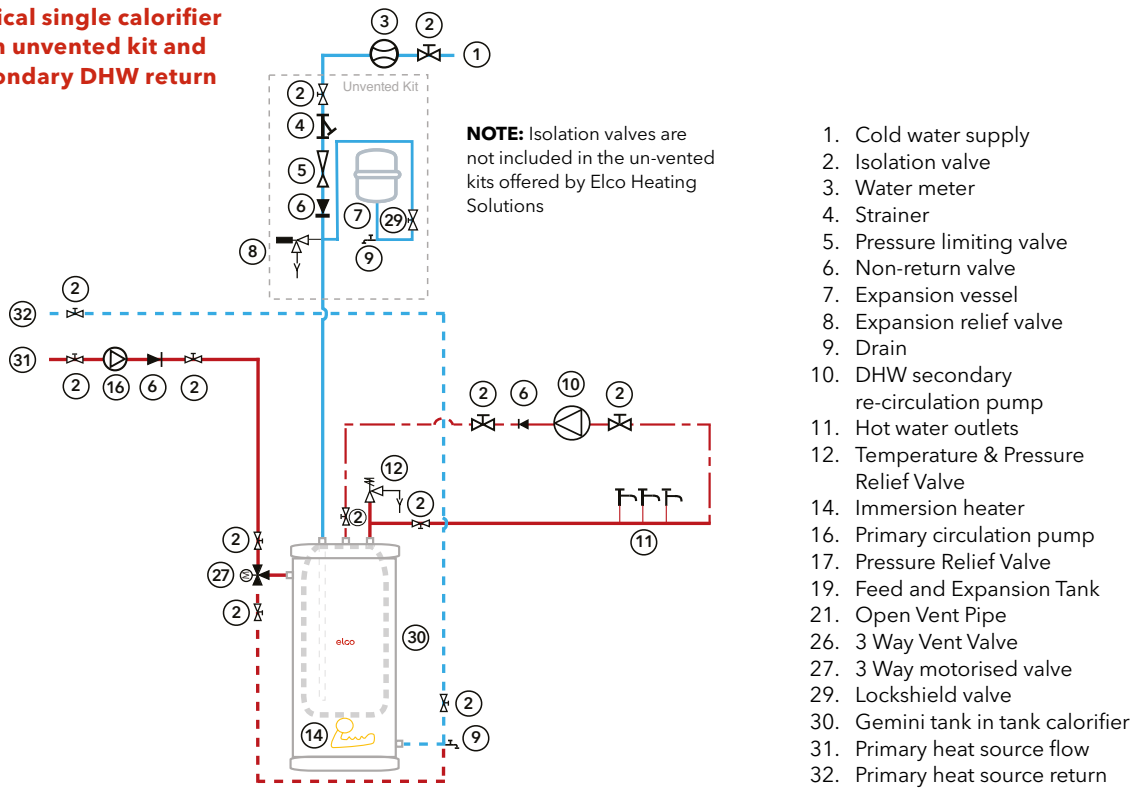

## Typical single calorifier open vented application

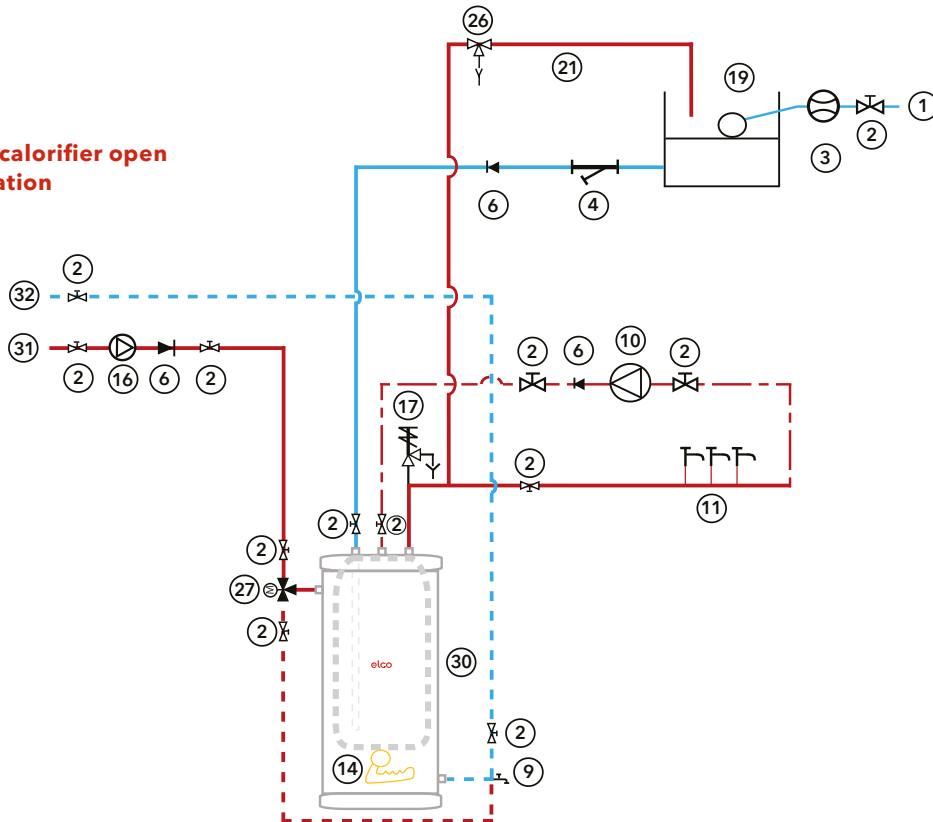

For more schematics please refer to the Installation and Operation manual or contact ELCO Heating Solutions

# Inox-Maxi SSB DHW Buffer Cylinder



- Stainless steel DHW buffer cylinder
- Extremely low standby heat losses

- Large connections
- Large inspection hatch

- Up to 3000 litres storage capacity

# Inox Maxi SSB DHW Stainless Steel Buffer Cylinder for medium to large applications

## Durable construction providing peace of mind

Constructed from 316L grade stainless steel providing excellent resistance to attack from corrosion.

## Extremely low standby heat losses

Increasing system efficiency due to the extremely low standby heat loss as low as 2.3 kW/24hr.

## Durability

The Inox-maxi SSB DHW buffer cylinders are manufactured from grade 316L stainless steel and in compliance with ErP Eco-Design requirements for Energy Related Products.

## External control

The stored DHW temperature can be monitored and controlled externally.



## A range of sizes

Eight models providing storage capacities ranging from 500 to 3000 litres.

## Cost effective

Due to the stainless steel construction of the unit, the cost of the yearly maintenance of the unit is greatly reduced by not requiring sacrificial anodes.

## Removable jacket

800L models and above are supplied with removable jackets and insulation.

## Immersion heater option

ELCO offers the option of adding an immersion heater. For more information please see the table on the right.

## Inspection hatch

Easy access to the base of the cylinder through the inspection hatch for yearly maintenance.

## Accessories

Matched optional/additional un-vented kits are available to assist with installation.

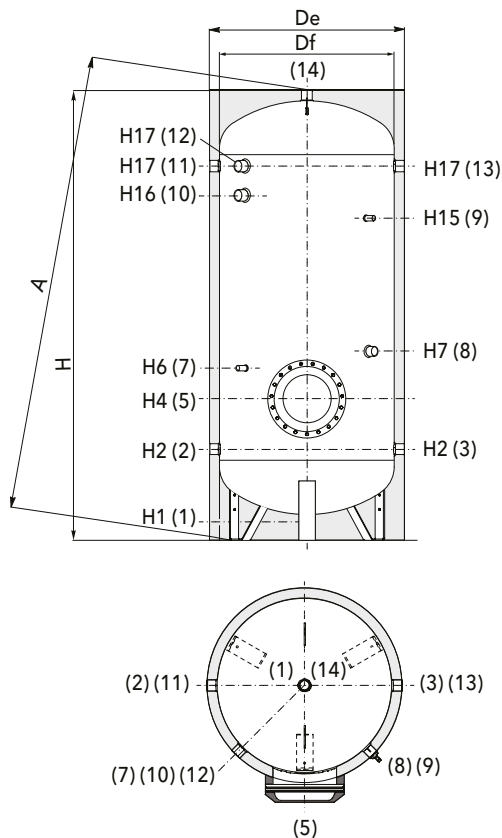

Item No.	Description
1	Drain
2	Domestic cold water inlet
3	Flow to external heat exchanger
5	Blind inspection flange
7	1/2" BSP tapping for instrumentation
8	Re-circulation
9	1/2" BSP tapping for instrumentation
10	Connection for immersion heater
11	Alternative return from external heat source
12	T&P valve
13	Return from external heat source
14	Domestic hot water outlet

# Technical data – Inox-Maxi SSB DHW Buffer Cylinder

Inox-Maxi SSB		500	800	1000	1300	1500	2000	2500	3000	
<b>Water</b>	Nominal storage capacity	litres	501	759	901	1272	1398	2018	2321	2927
	Maximum operating pressure	bar	6	6	6	6	6	6	6	6
	Maximum operating temperature	°C	95	95	95	95	95	95	95	95
<b>Energy</b>	Energy class		C	C	C	C	C	C	NA	NA
	Standby heat loss stored temperature 65°C	kw/24hr	2.3	2.7	2.8	3.5	3.8	4.3	-	-
<b>Electrical</b>	Optional electric elements	kw/phase	1.5 up to 3kW/1 Phase or 4 up to 6kW/3 Phase		1.5 up to 3kW/1 Phase or 4 up to 12kW/3 Phase					
<b>Misc.</b>	Weight empty/full	kg	90/597	134/893	154/1055	180/1452	200/1598	340/2358	409/2730	482/3409

## Dimensions

Inox-Maxi SSB	Df	De	H	A	H1	H2	H4	H6	H7	H15	H16	H17	5
	(mm)												
500	650	750	1805	1898	85	290	315	485	675	1295	1244	1400	Øe 180
800	790	1010	1943	1993	113	428	483	623	863	1433	1382	1538	Øe 240
1000	800	1020	2192	2257	112	427	482	622	912	1682	1632	1787	Øe 240
1300	950	1170	2213	2255	118	433	488	628	918	1688	1638	1793	Øe 240
1500	1000	1220	2197	2245	112	447	502	642	982	1652	1602	1757	Øe 240
2000	1250	1470	2119	2205	134	529	574	714	1004	1524	1473	1629	Øe 240
2500	1250	1300	2299	2617	134	529	574	714	954	1794	1710	1879	Øe 240
3000	1250	1300	2799	3065	134	529	574	714	1014	2294	2210	2369	Øe 240

## Connections

Inox-Maxi SSB	1	2, 3, 11, 13	7, 9,	8	10	12	14
	Gas F						
500	3/4"	1 1/4"	1/2"	1 1/4"	1 1/2"	2"	1 1/4"
800	3/4"	1 1/4"	1/2"	1 1/4"	1 1/2"	2"	1 1/2"
1000	3/4"	1 1/2"	1/2"	1 1/4"	2"	2"	1 1/2"
1300	1"	1 1/2"	1/2"	1 1/4"	2"	2"	2"
1500	1"	1 1/2"	1/2"	1 1/4"	2"	2"	2"
2000	1"	2"	1/2"	1 1/4"	2"	2"	2"
2500	1"	2"	1/2"	1 1/4"	2"	2"	2"
3000	1"	2"	1/2"	1 1/4"	2"	2"	2"

# Example of Hydraulic Scheme – Inox Maxi SSB DHW Buffer Cylinder

## Typical unvented water heater and buffer vessel schematic

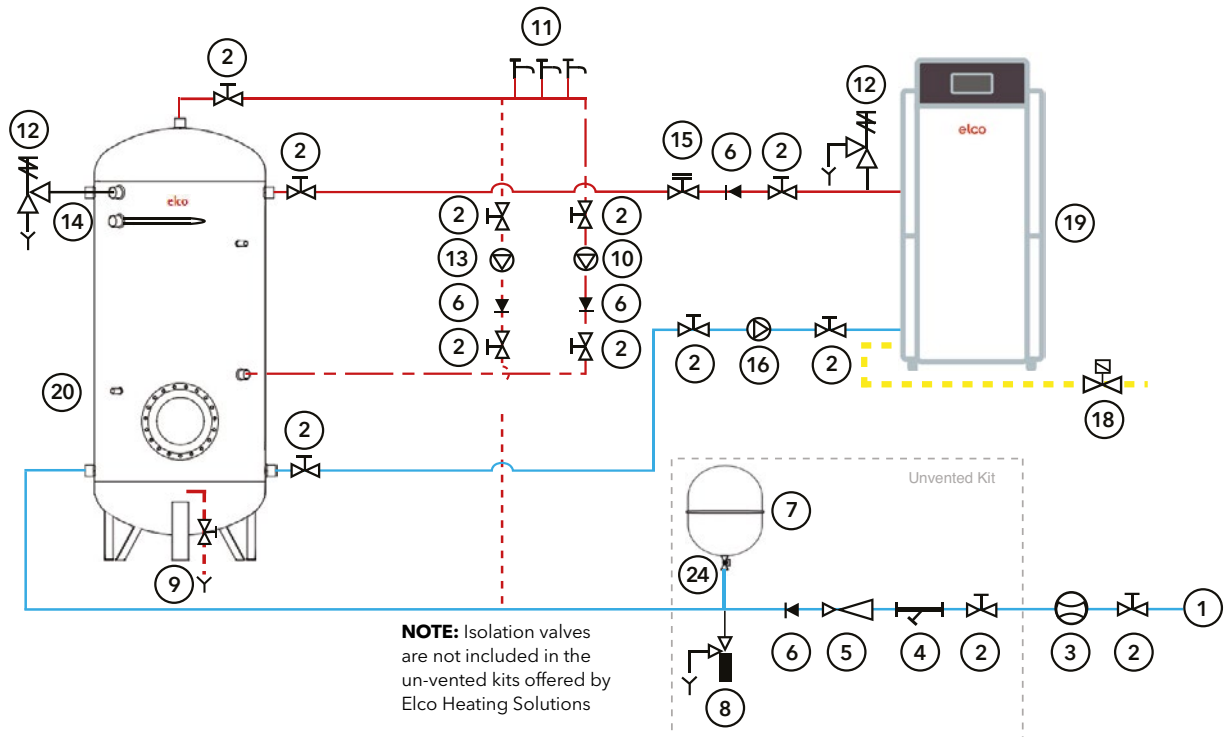

- |                            |                                           |                             |
|----------------------------|-------------------------------------------|-----------------------------|
| 1. Cold water supply       | 9. Drain                                  | 18. Gas shut-off valve      |
| 2. Isolation valve         | 10. DHW secondary re-circulation pump     | 19. TRIGON® XL Water Heater |
| 3. Water meter             | 11. Hot water outlets                     | 20. SSB buffer vessel       |
| 4. Strainer                | 12. Temperature and pressure relief valve | 24. Lockshield valve        |
| 5. Pressure limiting valve | 13. De-stratification pump                |                             |
| 6. Non-return valve        | 14. Immersion heater                      |                             |
| 7. Expansion vessel        | 15. Double regulating valve               |                             |
| 8. Expansion relief valve  | 16. DHW Primary Circulation Pump          |                             |

For more schematics please refer to the Installation and Operation manual or contact ELCO Heating Solutions

These illustrations are designed to provide general guidance on the hydraulic scheme and should not be considered as an installation drawing.

## Clearances

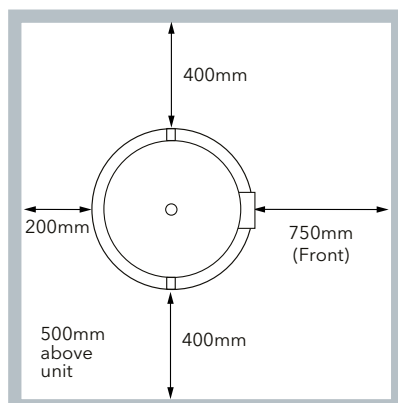



# Polywarm PWB DHW Buffer Cylinder



- Cost effective
- Extremely low standby heat losses

- Large connections
- Large inspection hatch

- Up to 3000 litres storage capacity

# Technical data – Polywarm PWB DHW Buffer Cylinder

## Large connections

Large connections on the cylinder which reduces the pressure drop within the unit.

## Extremely low standby heat losses

Increasing system efficiency due to the extremely low standby heat loss as low as 2.6 kW/24hr.

## Immersion heater option

Availability of an optional immersion element

## Economic

One of the most cost effective products on the market.

## Unvented kits

Matched optional/additional unvented kits are available to assist with installation.



## A range of sizes

Seven models providing storage capacities ranging from 500 to 3000 litres.

## Unique design

The Polywarm PWB cylinders are manufactured from carbon steel with a patented WRAS approved internal liner. The units are in compliance with ErP-Eco Design Requirements for Energy Related Products

## Compliance

Certified to KIWA UK Regulation 4

## A range of sizes

Seven models providing storage capacities ranging from 500 to 3000 litres.

## Insulation

All models are supplied with insulation and a removable jacket.

## External control

The stored DHW temperature can be monitored and controlled externally.

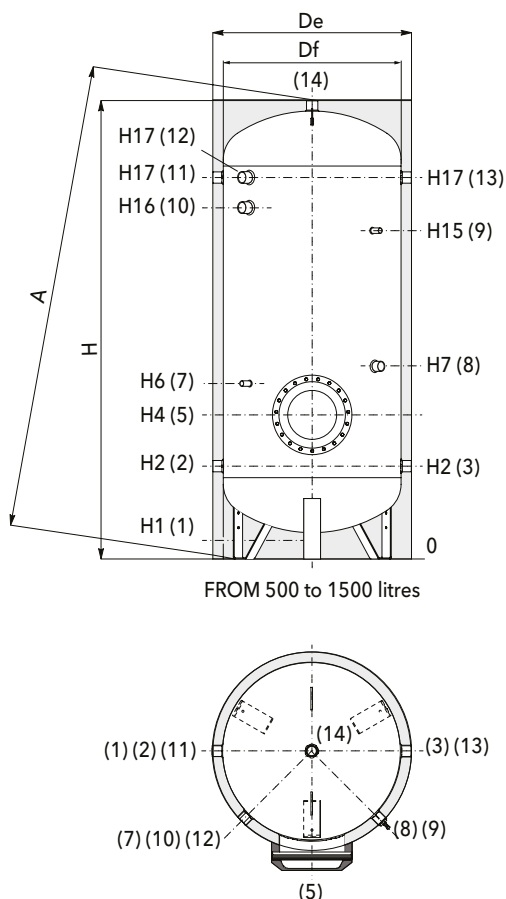

Item No.	Description
1	Drain
2	Domestic cold water inlet
3	Flow to external heat source
5	Blind inspection flange
7	1/2" BSP tapping for instrumentation
8	Re-circulation
9	1/2" BSP tapping for instrumentation
10	Connection for immersion heater
11	Alternative return from external heat source
12	T&P valve
13	Return from external heat source
14	Domestic hot water outlet
15	Drain 1" BSP (only models >1000L)

# Technical data – Polywarm PWB DHW Buffer Cylinder

Polywarm PWB			500	800	1000	1500	2000	2500	3000
Water	Nominal storage capacity	litres	500	791	1010	1442	1974	2310	2916
	Maximum operating pressure	bar	6	6	6	6	6	6	6
	Maximum operating temperature	°C	95	95	95	95	95	95	95
Energy	Energy class		C	C	C	C	C	-	-
	Standby heat loss stored temperature 65°C	kw/24hr	2.6	2.9	3.2	3.9	4.3	-	-
Electrical	Optional electric elements	kW/phase	1.5 up to 3kW/1 Phase or 4 up to 6kW/3 Phase			1.5 up to 3kW/1 Phase or 4 up to 12kW/3 Phase			
Misc.	Weight empty/full	kg	102 / 602	157 / 948	185 / 1192	233 / 1675	352 / 2326	388 / 2698	429 / 3345
	Magnesium anodes quantity/size		1/32 x 520	1/32 x 650	1/32 x 650	1/32 x 650	2/32 x 650	2/32 x 850	2/32 x 850

## Dimensions

Polywarm PWB	Df	De	H	A	H1	H2	H4	H6	H7	H15	H16	H17
	(mm)											
500	650	870	1891	2082	126	416	501	611	801	1411	1370	1526
800	750	970	2188	2393	113	433	518	628	898	1678	1638	1793
1000	850	1070	2188	2436	101	454	539	649	989	1645	1606	1760
1500	950	1170	2440	2706	109	440	525	635	1075	1935	1895	2050
2000	1100	1320	2492	2820	91	467	542	652	842	1952	1877	2057
2500	1250	1470	2361	2781	140	551	626	736	976	1816	1741	1891
3000	1250	1470	2861	3217	140	551	626	736	876	2316	2232	2391

## Connections

Polywarm PWB	1	2, 3, 11, 13	5	7 & 9	8	10	12	14
	Gas F							
500	1 1/4"	1 1/4"	Øi 300mm	1/2"	1 1/4"	1 1/2"	2"	1 1/4"
800	1 1/4"	1 1/4"	Øi 300mm	1/2"	1 1/4"	1 1/2"	2"	1 1/4"
1000	1 1/2"	1 1/2"	Øi 300mm	1/2"	1 1/4"	2"	2"	1 1/2"
1500	1"	1 1/2"	Øi 300mm	1/2"	1 1/4"	2"	2"	2"
2000	1"	2"	Øi 300mm	1/2"	1 1/4"	2"	2"	2"
2500	1"	2"	Øi 300mm	1/2"	1 1/4"	2"	2"	2"
3000	1"	2"	Øi 300mm	1/2"	1 1/4"	2"	2"	2"

# Installation schematics – Polywarm PWB DHW Buffer Cylinder

## Typical NHREC Gas Water Heater and 1 additional SSB or PWB DHW buffer vessels schematic

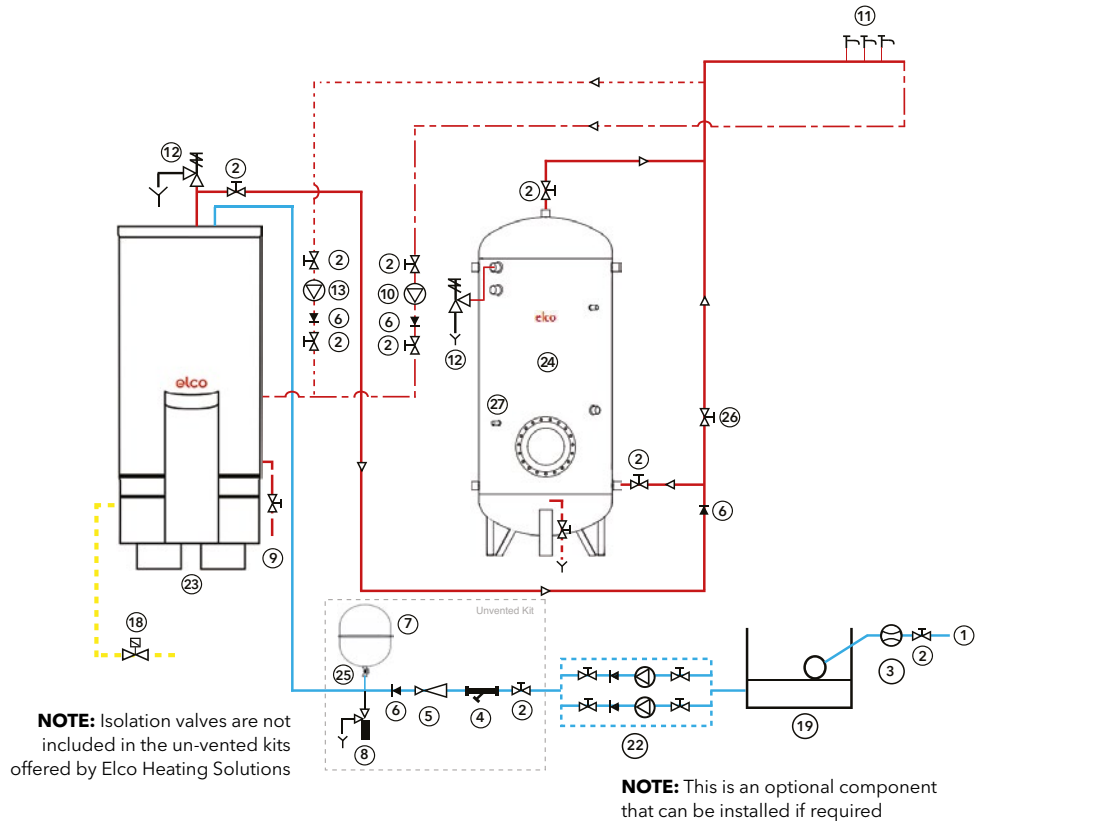

- |                            |                                           |                                   |
|----------------------------|-------------------------------------------|-----------------------------------|
| 1. Cold water supply       | 8. Expansion relief valve                 | 19. Cold water storage tank       |
| 2. Isolation valve         | 9. Drain                                  | 22. Cold water booster pump set   |
| 3. Water meter             | 10. DHW secondary re-circulation pump     | 23. NHREC water heater            |
| 4. Strainer                | 11. Hot water outlets                     | 24. PWB buffer vessel             |
| 5. Pressure limiting valve | 12. Temperature and pressure relief valve | 25. Lockshield valve              |
| 6. Non-return valve        | 13. Pump for Charging PWB buffer vessel   | 26. Normally closed valve         |
| 7. Expansion vessel        | 18. Gas shut-off valve                    | 27. Thermostat to control pump 13 |

For more schematics please refer to the Installation and Operation manual or contact ELCO Heating Solutions

These illustrations are designed to provide general guidance on the hydraulic scheme and should not be considered as an installation drawing.

### Clearances

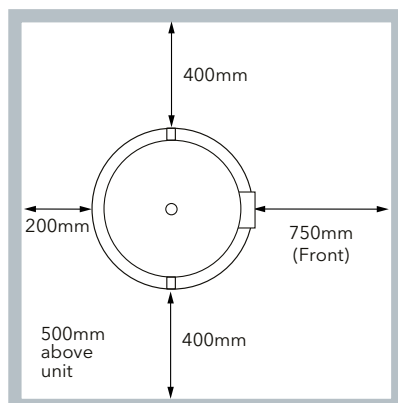

# Full range of accessories



## Flue gas systems

Non-room sealed:  
100mm

Room sealed:  
100/150mm



## Unvented kits



## Anodes

Magnesium and PROTech



## Expansion vessels

System and DHW



## Plate heat exchangers



## Immersion elements

# Case Study

## Studley castle

Studley, UK



### Luxury hotel benefits from ELCO package of Boilers and Calorifiers

As part of a major refurbishment, the 180-year-old Studley Castle in Warwickshire needed to refurbish its boiler plant to provide hotel guests with highly efficient and reliable heating and hot water generation.

#### Background

To fulfil the property's complex requirements, three ELCO TRIGON® XL 570kW floor standing boilers were specified and installed on the first floor of the main castle building, alongside eight x 500 litre INOX-MAXI cylinders.

The new equipment provides heating and hot water to the entire building, including: 209 bedrooms, which are spread across the main castle building and newly built accommodation wing; leisure facilities, with heated swimming pool and treatment rooms; restaurants, bars and entertainment venues; plus the main kitchen facilities. Space heating is supplied by radiators throughout the main castle building, while external areas and the entertainment venues utilise air handling units (AHUs) connected to the primary system.

When designing the provision of hot water, building services contractors for the project, LJJ, were acutely aware the system needed to deliver plentiful DHW for peak periods of demand. They had to factor in early mornings when guests shower before breakfast, as well as key points throughout a day to coincide with hotel entertainment finishing. As a result, ELCO supplied bespoke INOX-MAXI cylinders alongside the TRIGON® XL boilers, designed to cope with the peak hot water demands and provide reliable hot water delivery all year round.

#### Featured products:

TRIGON® XL



INOX-MAXI



**The TRIGON® XL represents a significant step forward in heating technology.**

With extremely flexible configurations, clever design and a range of models available, the boiler is perfect for a variety of commercial applications. Plus, extensive cascade arrangements of up to 8 boilers with a combined output of 4,560kW are possible.

**INOX-MAXI hot water cylinders can be supplied as direct or indirect and with either single or twin coils.**

Plus, with hot water buffer storage vessels and capacities from 500 to 3,000 litres, the designer of commercial hot water systems is well provided for with the INOX-MAXI range.



## Comment

Commenting on the project, Mechanical Contracts Manager at LJJ, Gerry McNally, said: "This was a prestigious project and therefore required a carefully designed, high quality heating system. We specified ELCO boilers for a number of reasons, but one of the most important was the longevity of the units and the guarantee of parts availability for many years to come. With the boilers utilising a stainless steel heat exchanger, we were satisfied that the equipment would be highly durable and reliable in this intense commercial application.

"We had also worked with ELCO on a previous project, and their Sales Manager, Brett Stokes, once again provided a first-class service.

We had support throughout the entire process, from the initial system designs, through to the delivery and commissioning of the units,

plus the enthusiasm from Brett and the entire ELCO team helped the project run smoothly."

Studley Castle is the latest member of the Warner Leisure Hotels' family, offering relaxing short breaks just for adults. Over 180 years old Studley Castle has been brought bang up to date and opened its doors in March 2019.

The TRIGON® XL range of floor standing gas condensing boilers is available in seven different models with outputs from 150-570kW, with all models offering a wealth of benefits, including: ultra-low NOx emissions complying with class 6 (2018) requirements, an 8 bar working pressure, 30k flow/return temperature differential, superb seasonal efficiencies and an ultra- compact footprint.

The boiler's impressive low NOx emissions are achieved by utilising a commercially proven premix-burner system, which includes a fully modulating, water cooled cold flame burner. This is combined with an optimised combustion system and stainless steel heat exchanger to provide a reliable and robust lifetime performance - while also offering gross seasonal efficiencies up to 97.5%.

**INOX-MAXI hot water cylinders can be supplied as direct or indirect models and with either single or twin coils.**

**Plus, with hot water buffer storage vessels and capacities from 500 to 3,000 litres, there is an INOX-MAXI for every commercial project.**

**For more information on commercial boilers, hot water generation or renewables, please visit: [www.elco.co.uk](http://www.elco.co.uk)**

# ELCO – A partner you can rely on

As a specialist partner, you can rely on ELCO's extensive expertise in heating and hot water generation, from planning right through to servicing and maintenance. Our specially trained technicians are available around the clock to help with the installation and commissioning of commercial heating and hot water systems – offering their experience and assistance when you need it the most.



## Commissioning

Our specialists always work together with you in commissioning an ELCO product properly to provide a high quality service.



## First class service

Whether it is repairs, maintenance or troubleshooting, our service technicians are there for you seven days a week.



## Trained and certified service technicians

Our ELCO service technicians are specially trained, qualified and fully equipped with the tools required to ensure all our products are maintained to the highest standards.

## More information

<b>Service Department</b>	01268 546770	service@elco.co.uk
<b>Spares Department</b>	01268 546771	spares@elco.co.uk
<b>Sales Department</b>	01268 207244	enquiries@elco.co.uk
<b>After Sales Technical</b>	01268 546772	technical@elco.co.uk
<b>Training</b>	01268 207244	marketing@elco.co.uk



[www.elco.co.uk](http://www.elco.co.uk)

## Your local contact is:



ELCO Heating Solutions Limited  
3 Juniper West, Fenton Way, Southfields Business Park,  
Basildon, Essex SS15 6SJ  
Tel: 0345 646 0442 Fax: 01268 888250  
[www.elco.co.uk](http://www.elco.co.uk)

